

EBM disconnect switches and enclosures

600 VAC heavy duty

Cl. I, Div. 1 & 2, Groups B, C, D
 Cl. II, Div. 1, Groups E, F, G
 Cl. II, Div. 2, Groups F, G
 Cl. III
 NEMA 3, 3R, 4^A, 4X^B, 7BCD, 9EFG, 12

Explosionproof
 Dust-ignitionproof
 Watertight
 Wet locations

2A

2A

Applications:

EBM hinged cover disconnect switches are used:

- To disconnect motors, lighting and other circuits
- In locations made hazardous by the presence of flammable gases or vapors or ignitable dusts
- Indoors or outdoors in damp, wet and dirty locations, or in areas where frequent wash downs, heavy rain or water spray is prevalent
- To provide disconnect means and short circuit protection (fusible version)
- On switch racks or other assemblies where it is desired that motor control be centrally located

Features:

- Rugged, corrosion-resistant cast copper-free aluminum construction (less than 0.4 of 1%)
- Switch operating handle, located through the right side wall of the body, permits visual confirmation of correct alignment and operation
- Total compliance to the wiring end room requirements of the National Electrical Code
- Semi-clamshell enclosure design, with an external flanged ground joint between body and cover, makes interior components more accessible
- Minimum enclosure-to-enclosure spacing with little interference between the opened cover and an adjacent enclosure
- Stainless steel hinges allow the cover to swing well out of the way
- Stainless steel quick release captive hex head cover bolts; stainless steel springs provide clear indication that cover bolts are fully retracted from the body
- Switch operating handle can be padlocked in either the "ON" or "OFF" position
- Neoprene cover gasket permanently attached to the cover seals out moisture
- Bodies have top and bottom drilled and tapped conduit entrances for power and conduits; removable reducers are supplied as standard, to accommodate smaller size conduit; all conduit entrances are plugged
- Tap on mounting feet

Certifications and compliances:

NEC/CEC:

- Class I, Divisions 1 & 2, Groups B, C, D
- Class II, Division 1, Groups E, F, G
- Class II, Division 2, Groups F, G
- Class III

UL standards:

- UL1203
- High AIC rating (interrupting capacity) for Class I, Division 1, Groups C, D only

Voltage (AC)	RMS symmetrical amperes
240	65,000
480	50,000
600	25,000

CSA standard:

- C22.2 No. 30

Environmental ratings:

- NEMA 3, 3R, 4^A, 4X^B, 7BCD, 9EFG, 12

Standard materials:

- Body and cover – copper-free aluminum
- Operating handle – copper-free aluminum
- Operating shaft and bushing – stainless steel
- Interior parts – sheet steel, electrogalvanized
- Cover bolts, washers and retractile springs – stainless steel
- Hinges – stainless steel

Electrical ratings:

- 600 VAC
- 30, 60 and 100 amperes



Options:

The following options are available from the factory by adding suffix to catalog number – suffixes are added alphanumerically.

Description	Suffix
• Ambient compensated circuit breaker trip setting	AC
• Pilot light, 120 VAC, red jewel, with blank indicating plate	J1^C
• Pilot light, 120 VAC, green jewel, with blank indicating plate	J3^C
• LED pilot lights (in place of standard incandescent lamps)	LED
• START-STOP pushbuttons (requires two spaces).....	PB23^C^A
• Space heater, 120V, 25 watts	R11
• Space heater, 240V, 25 watts	R22
• Space heater, 480V, 25 watts	R44
• Insulated neutral with two connectors	S146
• Standard drain (Class I, Groups B, C, D; Class II, Groups E, F, G; Class III) ..	S756^A
• Standard breather and drain (Class I, Groups B, C, D; Class II, Groups E, F, G; Class III) ..	S756V^A
• External epoxy finish	S752
• Internal and external epoxy finish.....	S753
• 12-point terminal block – 30 amp, 300V.....	S786
• General purpose control relay, 4-pole N.O., contacts rated 10A at 600V, coil 120 VAC, 50/60 Hz.....	S787
Auxiliary switch on circuit breaker:	
• 1A and 1B contacts	S784
• 2A and 2B contacts	S785

^A Enclosure not suitable for NEMA 4 or 4X with cover mounted operators.

^B With S752 or S753 suffix.

^C If desired, markings on indicating plates may be added to catalog number. Select from the list of standard markings and DSL legend plate listings in Section 3C.

EBM disconnect switches and enclosures

600 VAC heavy duty

Cl. I, Div. 1 & 2, Groups B, C, D

Cl. II, Div. 1, Groups E, F, G

Cl. II, Div. 2, Groups F, G

Cl. III

NEMA 3, 3R, 4[Ⓧ], 4X[Ⓧ], 7BCD, 9EFG, 12

Explosionproof
Dust-ignitionproof
Watertight
Wet locations

2A

2A

Ordering information:

To order an enclosure complete with disconnect switch, select the catalog number (based on the necessary rating of the switch) from the listing below.

Enclosures only can be ordered. Select from listings below.

Amperage	Maximum horsepower rating				Enclosure	
	AC polyphase			DC using 2 poles only	Cat. # With switch	Cat. # Without switch
	200 / 240V	440 / 480V	550 / 600V	250V max.	600 VAC	
Non-fusible						
30	10	20	25	7.5	EBMBB FD W30360	EBMBB FD
60	20	40	60	15	EBMBB FD W60360	EBMBB FD
100	30	75	75	25	EBMBD FD W10360	EBMBD FD
Fusible						
30	–	5	7.5	5	EBMBB FD W30361	EBMBB FD
60	–	15	15	10	EBMBB FD W60361	EBMBB FD
100	15	25	30	20	EBMBD FD W10361	EBMBD FD

Dimensions[Ⓧ] (in inches):

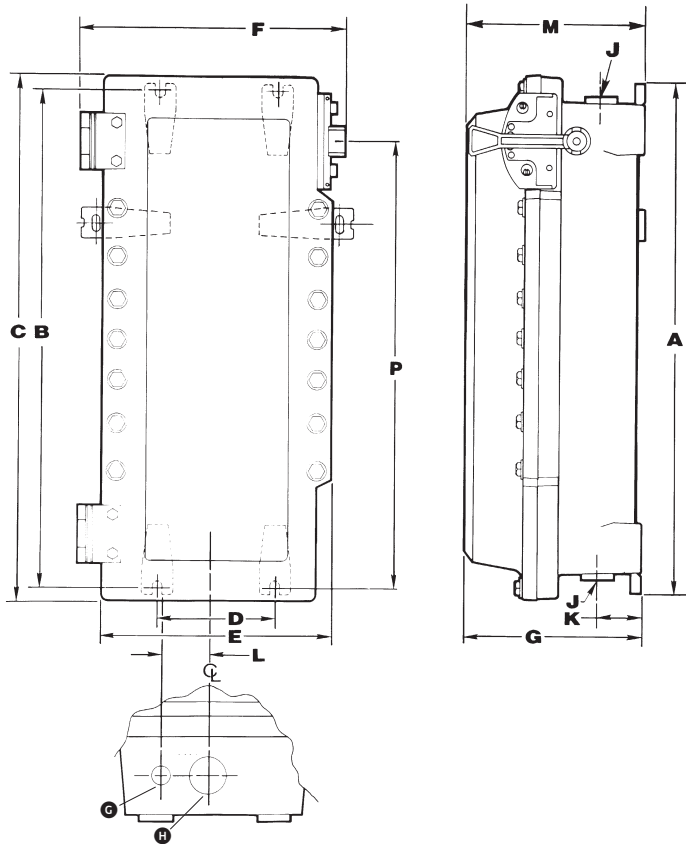

J[Ⓧ]
(conduit entry trade size)

Frame size	Cat. # Enclosure only	Enclosure size symbol	A	B	C	D	E	F	G	Drilled and tapped	With RE	K	L	M	P
30A, 60A	EBMBB	B	25.75	24.75	26.90	6.00	13.03	14.46	10.25	2"	1.5"	3.25	3.13	10.25	22.00
100A	EBMBD	D	28.25	27.25	29.40	6.00	13.03	14.46	10.25	3"	2.5"	3.25	3.13	10.25	24.50

[Ⓧ] Enclosure not suitable for NEMA 4 or 4X with cover mounted operators.

[Ⓧ] With S752 or S753 suffix.

[Ⓧ] Dimensions are approximate, not for construction purposes.

[Ⓧ] 1" drilled and tapped conduit entry for control conductors supplied with PLG plug (top and bottom).

[Ⓧ] Conduit entrance(s) for power conductors (top and bottom). All conduit entrance(s) supplied with RE reducer and PLG plug.

Authorised Distributor:

AMPMECH

46, Jalan SS 22/21, Damansara Jaya,
47400 Petaling Jaya,
Selangor Darul Ehsan, Malaysia.

Email: ampmech@ampmech.com
Website: www.ampmech.com