

BHR dead front interlocked receptacles with factory sealed switch

Cl. I, Div. 1 & 2, Groups B, C, D
 Cl. II, Div. 1 & 2, Groups F, G
 Cl. III
 NEMA 3, 4, 7BCD, 9FG, 12

Explosionproof
 Dust-ignitionproof
 Raintight
 Wet Locations

4P

Applications:

BHR dead front interlocked receptacles and switches with BHP plugs are used:

- To supply power to portable electrical equipment, such as motor generator sets, compressors, heating and cooling units, lighting systems, conveyors and similar equipment
- Primarily in areas which are hazardous due to the presence of hydrogen or gases, or vapors of equivalent hazard, such as manufactured gas
- In damp, wet or corrosive locations
- Indoors or outdoors in hydrogen areas of process industries, missile bases where hydrogen fuel is used and gas manufacturing plants

Features:

- BHR receptacles feature a built-in rotary switch which is operated automatically when the plug is inserted and withdrawn; the switch, capable of making and breaking the circuit at full rated load, is operated by a helical blade in the center of the plug
- The plug and receptacle contacts cannot be made or broken under load; when the plug is inserted, the plug and receptacle contacts engage before the switch closes; when the plug is withdrawn, the switch opens before the plug and receptacle contacts disengage; this sequence of operation provides maximum safety in a dead front receptacle; arcing is isolated in a flame and dusttight chamber
- Operation is simple, safe and positive; to disconnect the portable device, the plug fastening ring is unscrewed and the plug simply pulled straight out; no separate interlock device or operating handle need to be actuated
- Positive engagement without mismatching is assured by a distinct physical polarization of the plug and receptacle in every rating
- Plugs are furnished with pressure terminations; receptacles are furnished with flexible leads for splicing to the supply conductors; a large threaded cover provides access to the wiring compartment
- Assemblies are available for top, bottom or through feed conduit arrangements in $\frac{3}{4}$ " to 2" sizes

Certifications and compliances:

- Class I, Divisions 1 & 2, Groups B, C, D
- Class II, Divisions 1 & 2, Groups F, G
- Class III
- NEMA 3, 4, 7BCD, 9FG, 12
- ANSI/UL standard: UL1010

Standard materials:

- Receptacle housings – copper-free aluminum
- Seals – malleable iron
- Plug exteriors – copper-free aluminum
- Insulation – high impact glass filled phenolic
- Contacts – brass

Standard finishes:

- Copper-free aluminum – natural
- Malleable iron – electrogalvanized and aluminum lacquer
- Phenolic – natural (black)
- Brass – silver plated

Options:

Description

Suffix

- Special polarity..... **Details upon request**

Where two or more receptacles of the same ampere rating and number of poles are to be installed in the same area for use on different voltages

Electrical ratings:

- 30, 60, 100 amperes; 480 VAC



BHR/BHP in use



BHR/BHP separated, showing helical driver

Grounding:

- BHR receptacles and BHP plugs are provided with an extra grounding pole. In plugs, provision is made for attachment of the grounding wire to the grounding pole. In addition, direct connection is provided between the plug and receptacle housings and the grounding pole. In the receptacle, grounding is accomplished through the conduit system.

CAUTION: To reduce the risk of ignition of hazardous atmospheres, do not use plugs or receptacles in Class II, Group F locations that contain electrically conductive dusts.

Dimensions (in inches):

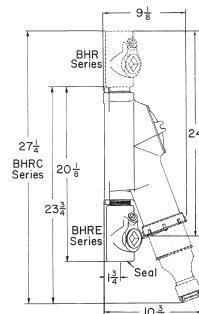

BHR/BHP

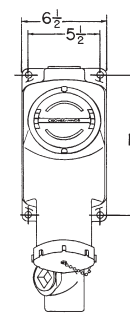

BHR only

BHR dead front interlocked receptacles with factory sealed switch

Cl. I, Div. 1 & 2, Groups B, C, D
Cl. II, Div. 1 & 2, Groups F, G
Cl. III
NEMA 3, 4, 7BCD, 9FG, 12

Explosionproof
Dust-ignitionproof
Raintight
Wet Locations

4P

Ordering information:

Receptacles are supplied ready to install with a threaded cap. Through feed hubs are standard. Sealing fittings, nipples and closure plugs ordered separately depending on application. Receptacles can be configured for top feed, bottom feed or through feed.

Amperage	Configuration	Hub size	Cat. #
30	2-wire, 3-pole	3/4"	BHRC3382N
	2-wire, 3-pole	1"	BHRC3383N
	3-wire, 4-pole	3/4"	BHRC3482D
	3-wire, 4-pole	1"	BHRC3483D
	4-wire, 5-pole	1"	BHRC3583 NW
	4-wire, 5-pole	1 1/4"	BHRC3584 NW
60	2-wire, 3-pole	1 1/4"	BHRC6384N
	2-wire, 3-pole	1 1/2"	BHRC6385N
	3-wire, 4-pole	1 1/4"	BHRC6484D
	3-wire, 4-pole	1 1/2"	BHRC6485D
	4-wire, 5-pole	1 1/4"	BHRC6584 NW
	4-wire, 5-pole	1 1/2"	BHRC6585 NW
100	2-wire, 3-pole	1 1/4"	BHRC10384N
	2-wire, 3-pole	1 1/2"	BHRC10385N
	3-wire, 4-pole	1 1/2"	BHRC10485D
	3-wire, 4-pole	2"	BHRC10486D
	4-wire, 5-pole	1 1/2"	BHRC10585 NW
	4-wire, 5-pole	2"	BHRC10586 NW



BHP plugs

480 VAC, 60-400 Hz

BHP plugs mate to BHR receptacles. Plugs are supplied with threaded locking ring that threads onto receptacle housing for secure connection and environmental seal. Mechanical external cord grip and neoprene bushing provided for secure cord retention and environmental seal.

Amperage	Configuration	Cable diameter	Cat. #
30	2-wire, 3-pole	0.500 - 0.875"	BHP3383N
	2-wire, 3-pole	0.875 - 1.375"	BHP3385N
	3-wire, 4-pole	0.500 - 0.875"	BHP3483D
	3-wire, 4-pole	0.875 - 1.375"	BHP3485D
	4-wire, 5-pole	0.500 - 0.875"	BHP3583 NW
	4-wire, 5-pole	0.875 - 1.375"	BHP3585 NW
60	2-wire, 3-pole	0.500 - 0.875"	BHP6383N
	2-wire, 3-pole	0.875 - 1.375"	BHP6385N
	3-wire, 4-pole	0.500 - 0.875"	BHP6483D
	3-wire, 4-pole	0.875 - 1.375"	BHP6485D
	4-wire, 5-pole	0.875 - 1.375"	BHP6585 NW
	4-wire, 5-pole	1.375 - 1.875"	BHP6587 NW
100	2-wire, 3-pole	0.875 - 1.375"	BHP10385N
	2-wire, 3-pole	1.375 - 1.875"	BHP10387N
	3-wire, 4-pole	0.875 - 1.375"	BHP10485D
	3-wire, 4-pole	1.375 - 1.875"	BHP10487D
	4-wire, 5-pole	0.875 - 1.375"	BHP10585 NW
	4-wire, 5-pole	1.375 - 1.875"	BHP10587 NW



4P

SRD dead front interlocked receptacles with factory sealed switch

Cl. I, Div. 1 & 2, Group D
Cl. II, Div. 1 & 2, Groups F, G
Cl. III
NEMA 3, 7D, 9FG, 12

Explosionproof
Dust-ignitionproof
Raintight
Wet Locations

4P

Applications:

SRD dead front interlocked receptacles and switches with SP plugs are used:

- To supply power to portable electrical equipment, such as motor generator sets, compressors, heating and cooling units, lighting systems, conveyors and similar equipment
- In areas which are hazardous due to the presence of flammable vapors or gases and combustible dusts
- In damp, wet or corrosive locations
- Indoors or outdoors at petroleum refineries, chemical and petrochemical plants, as well as facilities for processing and handling grain, flour and starch

Features:

- SRD receptacles feature a built-in rotary switch that operates automatically when the plug is inserted and withdrawn; the switch, capable of making and breaking the circuit at full rated load, is operated by a helical blade in the center of the plug
- The plug and receptacle contacts cannot be made or broken under load; when the plug is inserted, the plug and receptacle contacts engage before the switch closes; when the plug is withdrawn, the switch opens before the plug and receptacle contacts disengage; this sequence of operation provides the maximum safety of a dead front receptacle; arcing is isolated in a flame and dusttight chamber
- Operation is simple, safe and positive; to disconnect the portable device, the plug is simply pulled straight out; no separate interlock device or operating handle need to be actuated
- Positive engagement without mismatching is assured by a distinct physical polarization of plug and receptacle in every rating
- Plugs are furnished with pressure terminations; receptacles are furnished with flexible leads for splicing to the supply conductors; a threaded cover at the top provides access to the wiring compartment
- Back box is provided with 1 1/4" vertical through feed hubs

Certifications and compliances:

NEC:

- Class I, Divisions 1 & 2, Group D
- Class II, Divisions 1 & 2, Groups F, G
- Class III

NEMA:

- NEMA 3, 7D, 9FG, 12

ANSI/UL standard:

- UL1010

Standard materials:

- Back box – Feraloy iron alloy
- Threaded cover – copper-free aluminum
- Receptacle housings and plug exteriors – copper-free aluminum
- Insulation – high impact glass filled phenolic
- Contacts – brass

Standard finishes:

- Feraloy iron alloy – electrogalvanized and aluminum acrylic paint
- Copper-free aluminum – natural
- Phenolic – natural (black)
- Brass – silver plated

Options:

Description Suffix

- Special polarity..... **Details upon request**

Where two or more receptacles of the same ampere rating and number of poles are to be installed in the same area for use on different voltages

Electrical ratings:

- 30 and 60 amperes; 480 VAC
- SP plugs – 480 VAC, 60-400 Hz

Grounding:

- SRD receptacles and SP plugs are provided with an extra grounding pole. In plugs, provision is made for attachment of a grounding wire to the grounding pole. In addition, direct connection is provided between plug and receptacle housings and the grounding pole. In the receptacle, grounding is accomplished through the conduit system.

CAUTION: To reduce the risk of ignition of hazardous atmospheres, do not use plugs or receptacles in Class II, Group F locations that contain electrically conductive dusts.

Dimensions (in inches):

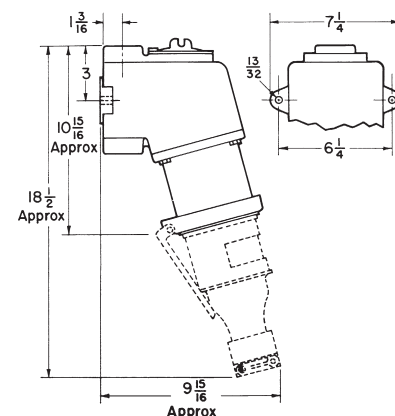

SRD dead front interlocked receptacles with factory sealed switch

Cl. I, Div. 1 & 2, Group D
Cl. II, Div. 1 & 2, Groups F, G
Cl. III
NEMA 3, 7D, 9FG, 12

Explosionproof
Dust-ignitionproof
Raintight
Wet Locations

4P

Ordering information:



SRD receptacle with spring door



SP plug



SRD receptacle with threaded cap



SP plug with fastening ring

Back box – 1 1/4" vertical through feed hubs

Amperage	Description	Cat. # With spring door	With cable grip and neoprene bushing		Cat. # With threaded cap	With cable grip and neoprene bushing	
			Cable diameter	Cat. #		Cable diameter	Cat. #
30	2-wire, 3-pole	SRD3324N	0.500 - 0.875"	SP3363N	SRD3384N	0.500 - 0.875"	SP3383N
			0.875 - 1.375"	SP3365N		0.875 - 1.375"	SP3385N
	3-wire, 4-pole	SRD3424D	0.500 - 0.875"	SP3463D	SRD3484D	0.500 - 0.875"	SP3483D
			0.875 - 1.375"	SP3465D		0.875 - 1.375"	SP3485D
4-wire, 5-pole	SRD3524 NW	0.500 - 0.875"	SP3563 NW	SRD3584 NW	0.500 - 0.875"	SP3583 NW	
		0.875 - 1.375"	SP3565 NW		0.875 - 1.375"	SP3585 NW	
60	2-wire, 3-pole	SRD6324N	0.500 - 0.875"	SP6363N	SRD6384N	0.500 - 0.875"	SP6383N
			0.875 - 1.375"	SP6365N		0.875 - 1.375"	SP6385N
	3-wire, 4-pole	SRD6424D	0.500 - 0.875"	SP6463D	SRD6484D	0.500 - 0.875"	SP6483D
			0.875 - 1.375"	SP6465D		0.875 - 1.375"	SP6485D
	4-wire, 5-pole	SRD6524 NW	0.875 - 1.375"	SP6565 NW	SRD6584 NW	0.875 - 1.375"	SP6585 NW
			1.375 - 1.875"	SP6567 NW		1.375 - 1.875"	SP6587 NW

Authorised Distributor:



46, Jalan SS 22/21, Damansara Jaya,
47400 Petaling Jaya,
Selangor Darul Ehsan, Malaysia.

Email: ampmech@ampmech.com

Website: www.ampmech.com