

- > Port size: 1/4" ... 1 1/2" (ISO G/NPT)
1/2" ... 2" (Flanged)
- > Zone 0, Exia solenoid pilot operated valve
- > Safety integrity SIL1/SIL2
- > Reliable and long life, ideal for a one time installation
- > A pilot assisted solenoid operated valve for the control of pneumatic or hydraulic operated equipment
- > Global Approvals ATEX, IECEx, TRCU, NEPSI.
- > Environmental protection; NEMA 4X, IP66/X8



Technical features

Medium:

Hydraulic and pneumatic – customer to specify and confirm compatibility

Operation:

Indirect solenoid operated poppet valves

Mounting position:

Solenoid vertical

Flow:

0,8 Cv, (11,5 Kv) to 28 Cv (403 Kv)

Port size:

1/4 ... 1 1/2 NPT, G1/4 ... G1 1/2, Flanged 1/2 ... 2 available on request

Solenoid pilot port size:

1/4 NPT or G1/4

Operating pressure:

0 ... 20 bar (0 ... 290 psi)
0 ... 50 bar (0 ... 725 psi)
0 ... 207 bar (0 ... 3002 psi)

Pilot pressure:

3 ... 8 bar (43 ... 116 psi)

Temperature:

Media:
-20 ... +90°C (-4 ... +194°F)
Ambient:
-40 ... +64°C (-40 ... +147°F)
Air supply must be dry enough to avoid ice formation at temperatures below +2°C (+35°F).

Materials:

Valve body, trim, coil housing and top cover:
stainless steel 1.4404 (316 L)
O-rings seats & seals: high NBR

Other seat/seal materials available

Technical data – standard models

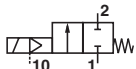
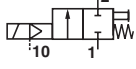
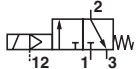
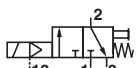
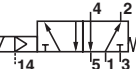
Symbol	Port size	Function	Operating pressure (bar)	Material Seat seal	Manual override/ reset	Conduit connection	Certification	Weight (kg)	Dimension No.	Model
	1/4 NPT	2/2 NC	0 ... 20	NBR	Without	M20 x 1,5	Ex ia IIC T6	4.5	1	Y2H21AA1SA10300
	G 1/4	2/2 NC	0 ... 20	NBR	Without	M20 x 1,5	Ex ia IIC T6	4.5	1	Y2H21AE1SA10300
	1/2 NPT	2/2 NC	0 ... 20	NBR	Without	M20 x 1,5	Ex ia IIC T6	6	2	Y2H21AA3SA10300
	G 1/2	2/2 NC	0 ... 20	NBR	Without	M20 x 1,5	Ex ia IIC T6	6	2	Y2H21AE3SA10300
	1/4 NPT	2/2 NC	0 ... 20	NBR	PBMR*1)	M20 x 1,5	Ex ia IIC T6	6	3	Y2H21PA1SA10300
	G 1/4	2/2 NC	0 ... 20	NBR	PBMR*1)	M20 x 1,5	Ex ia IIC T6	6	3	Y2H21PE1SA10300
	1/2 NPT	2/2 NC	0 ... 20	NBR	PBMR*1)	M20 x 1,5	Ex ia IIC T6	8	4	Y2H21PA3SA10300
	G 1/2	2/2 NC	0 ... 20	NBR	PBMR*1)	M20 x 1,5	Ex ia IIC T6	8	4	Y2H21PE3SA10300
	1/4 NPT	3/2 UNI	0 ... 20	NBR	Without	M20 x 1,5	Ex ia IIC T6	6.5	5	Y2H23AA1SA10300
	G 1/4	3/2 UNI	0 ... 20	NBR	Without	M20 x 1,5	Ex ia IIC T6	6.5	5	Y2H23AE1SA10300
	1/2 NPT	3/2 UNI	0 ... 20	NBR	Without	M20 x 1,5	Ex ia IIC T6	8	6	Y2H23AA3SA10300
	G 1/2	3/2 UNI	0 ... 20	NBR	Without	M20 x 1,5	Ex ia IIC T6	8	6	Y2H23AE3SA10300
	1 NPT	3/2 UNI	0 ... 20	NBR	Without	M20 x 1,5	Ex ia IIC T6	25	7	Y2H23AA6SA10300
	G 1	3/2 UNI	0 ... 20	NBR	Without	M20 x 1,5	Ex ia IIC T6	25	7	Y2H23AE6SA10300
	1/4 NPT	3/2 UNI	0 ... 50	NBR	Without	M20 x 1,5	Ex ia IIC T6	6.5	5	Y2H33AA1SA10300
	G 1/4	3/2 UNI	0 ... 50	NBR	Without	M20 x 1,5	Ex ia IIC T6	6.5	5	Y2H33AE1SA10300
	1/4 NPT	3/2 UNI	0 ... 207	NBR	Without	M20 x 1,5	Ex ia IIC T6	6.5	5	Y2H63AA1SA10300
	G 1/4	3/2 UNI	0 ... 207	NBR	Without	M20 x 1,5	Ex ia IIC T6	6.5	5	Y2H63AE1SA10300
	1/4 NPT	3/2 UNI	0 ... 20	NBR	PBMR*1)	M20 x 1,5	Ex ia IIC T6	6.5	8	Y2H23PA1SA10300
	G 1/4	3/2 UNI	0 ... 20	NBR	PBMR*1)	M20 x 1,5	Ex ia IIC T6	6.5	8	Y2H23PE1SA10300
	1/2 NPT	3/2 UNI	0 ... 20	NBR	PBMR*1)	M20 x 1,5	Ex ia IIC T6	8	9	Y2H23PA3SA10300
	G 1/2	3/2 UNI	0 ... 20	NBR	PBMR*1)	M20 x 1,5	Ex ia IIC T6	8	9	Y2H23PE3SA10300
	1/4 NPT	5/2	0 ... 20	NBR	Without	M20 x 1,5	Ex ia IIC T6	6.5	10	Y2H25AA1SA10300
	G 1/4	5/2	0 ... 20	NBR	Without	M20 x 1,5	Ex ia IIC T6	6.5	10	Y2H25AE1SA10300

Other operators, pressures and functions available - please see product selector on page 2.

Other products and body materials available consult Maxseal technical service for further information.

*1) PBMR = Push button manual reset

Technical data – solenoid operators

Nominal voltages	12 V d.c. via an energy limiting barrier
Pull-in voltage	>=85% of nominal
Response times	Pull-in < 150 ms, drop out < 80ms
Drop-out voltage	10 ... 20% of nominal
Coil rating	340 ohms

Power consumption	0,5 watts
Voltage protection	Surge suppression diodes fitted as standard
Coil encapsulation	Class H
Leak performance	Bubble tight
Coil duty cycle	100%

Option selector

Y2***S*1-03-00**

Seat /seal material	Substitute
High nitrile	H
FKM	V
Nylon /High nitrile	J *
Nylon / FKM	K*
Low nitrile	L
Pressure range	Substitute
0 ... 20 bar (all valves)	2
0 ... 50 bar (0 ... 725 psi) (2/2 & 3/2 way valves only)	3
0 ... 207 (2/2 & 3/2 way valves only)	6
Function	Substitute
2 /2 NC (normally closed)	1
2 /2 NO (normally open)	2
3/2	3
5/2	5
Operation	Substitute
Automatic	A
Automatic latching lever (0 ... 20 bar only)	B
Push button manual reset	P
Jack screw manual override (3/2 valve only)	S

Conduit / Solenoid pilot port size	Substitute
M20 ISO / 1/4 NPT	A
M20 ISO / 1/4 BSP	B
1/2 NPT / 1/4 NPT	D
1/2 NPT / 1/4 BSP	E
Port size	Substitute
1/4 NPT	A1
1/2 NPT	A3
3/4 NPT	A5
1 NPT	A6
1 1/2 NPT	A8
G 1/4	E1
G 1/2	E3
G 3/4	E5
G 1	E6
G 1 1/2	E8

* Greater than 50 bar operating pressure

Dimensions

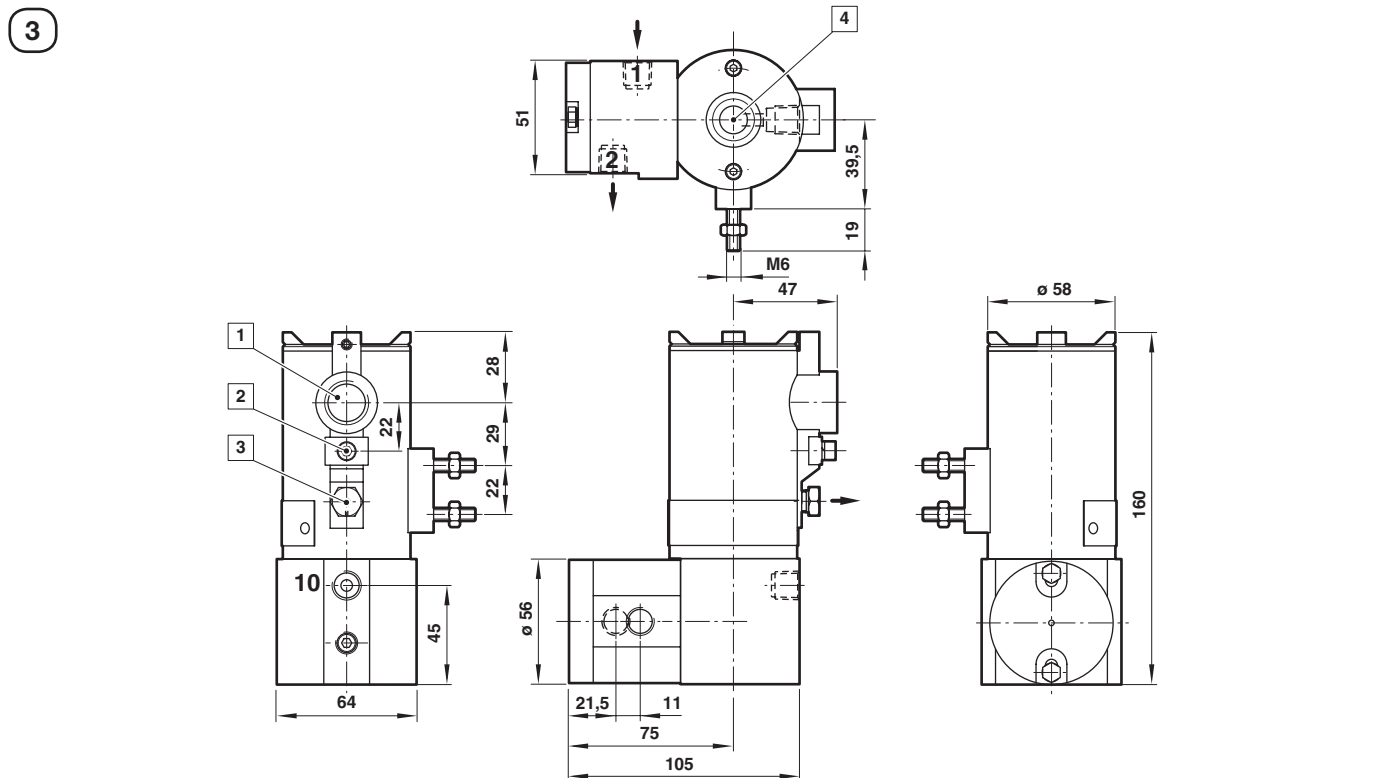
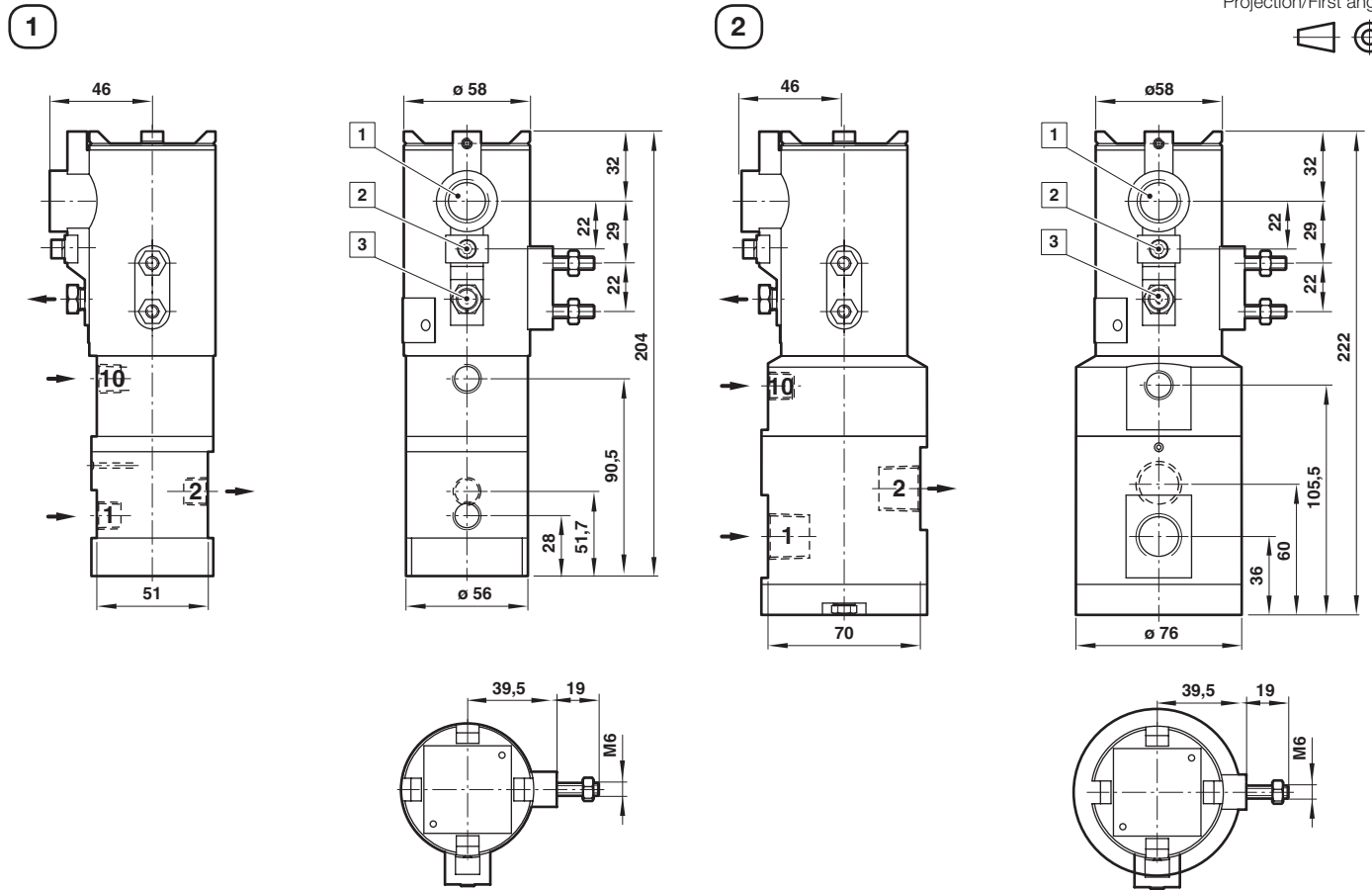
 Dimensions in mm
 Projection/First angle

- 1** Conduit connection M20 x 1,5 or 1/2 NPT
- 2** External earth
- 3** Pilot exhaust plugged
- 4** Manual reset (PBMR)

4

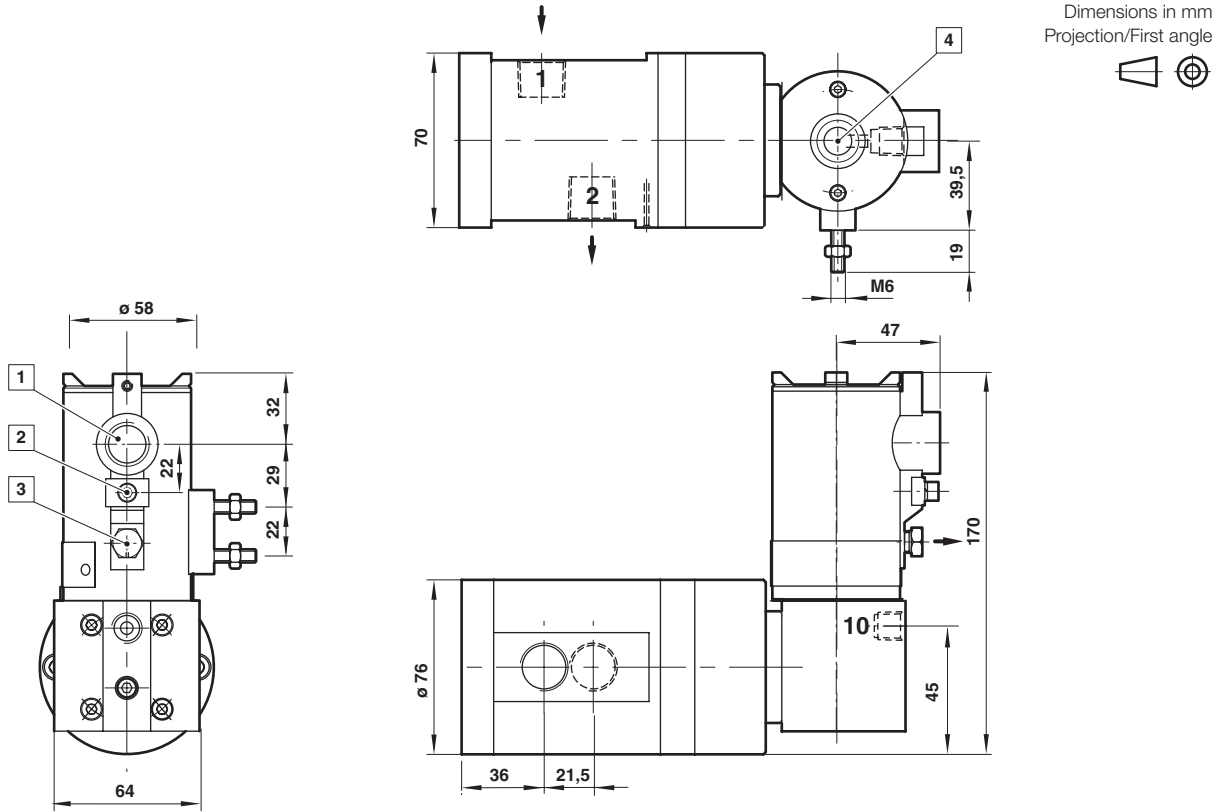

5

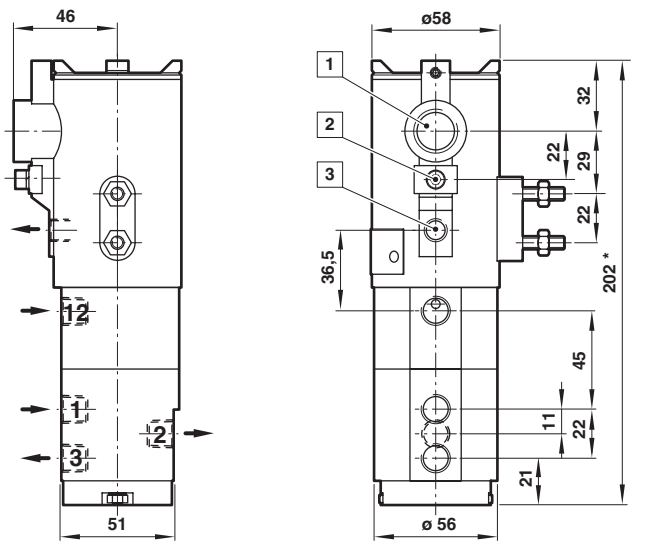

* 209mm for 207 bar valve

6

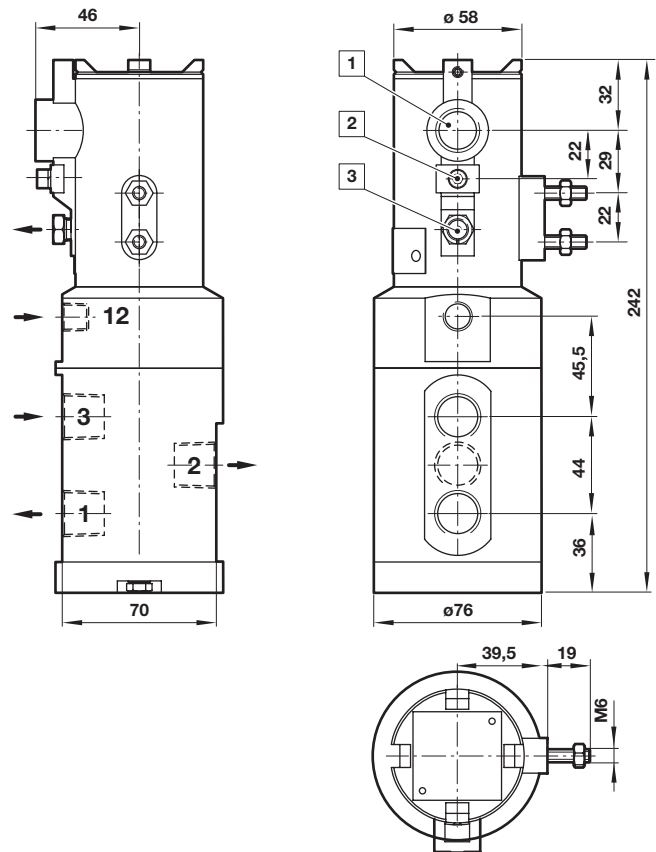

- 1 Conduit connection M20 x 1,5 or 1/2 NPT
- 2 External earth
- 3 Pilot exhaust plugged
- 4 Manual reset (PBMR)



Dimensions in mm
Projection/First angle



7

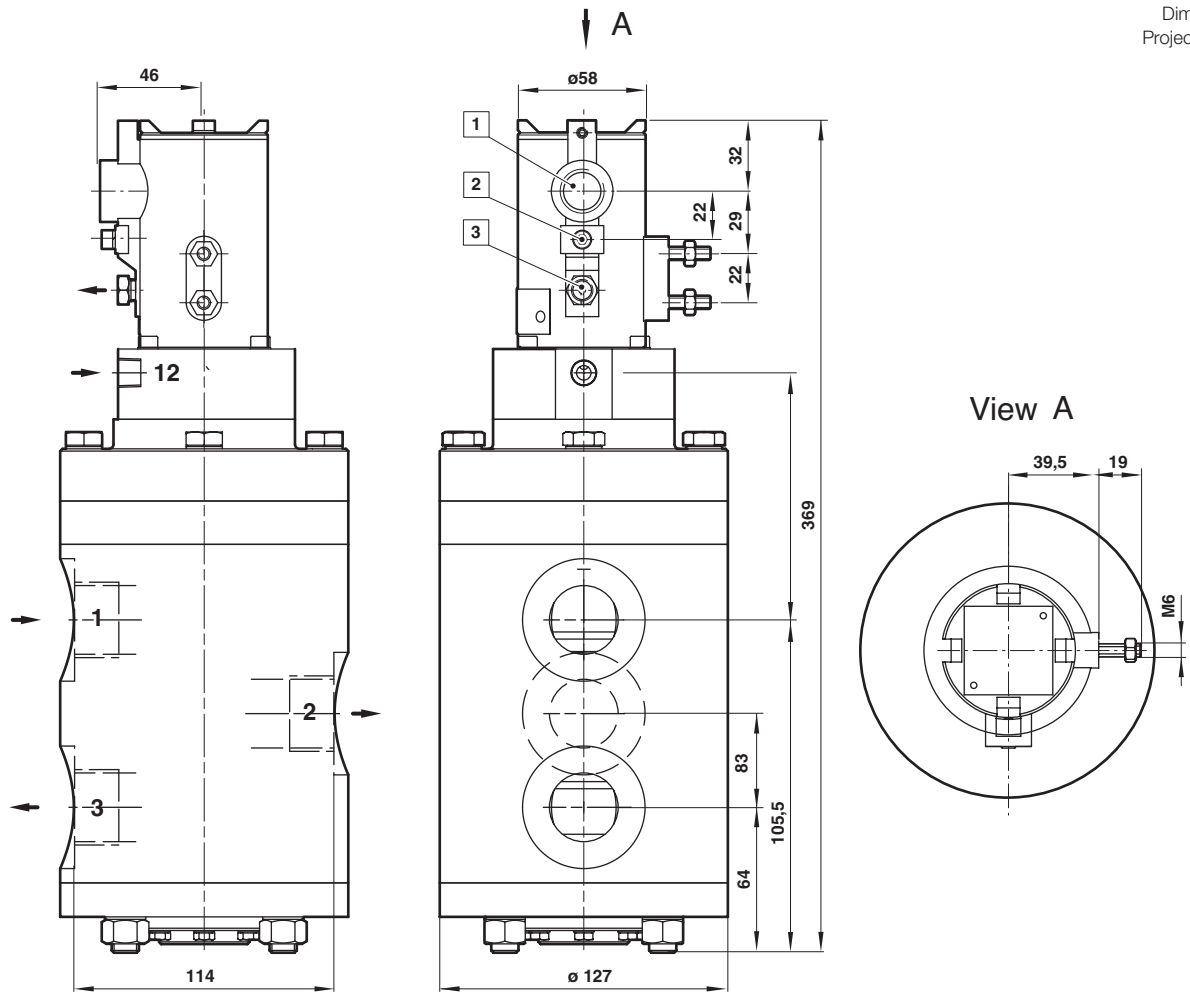

8

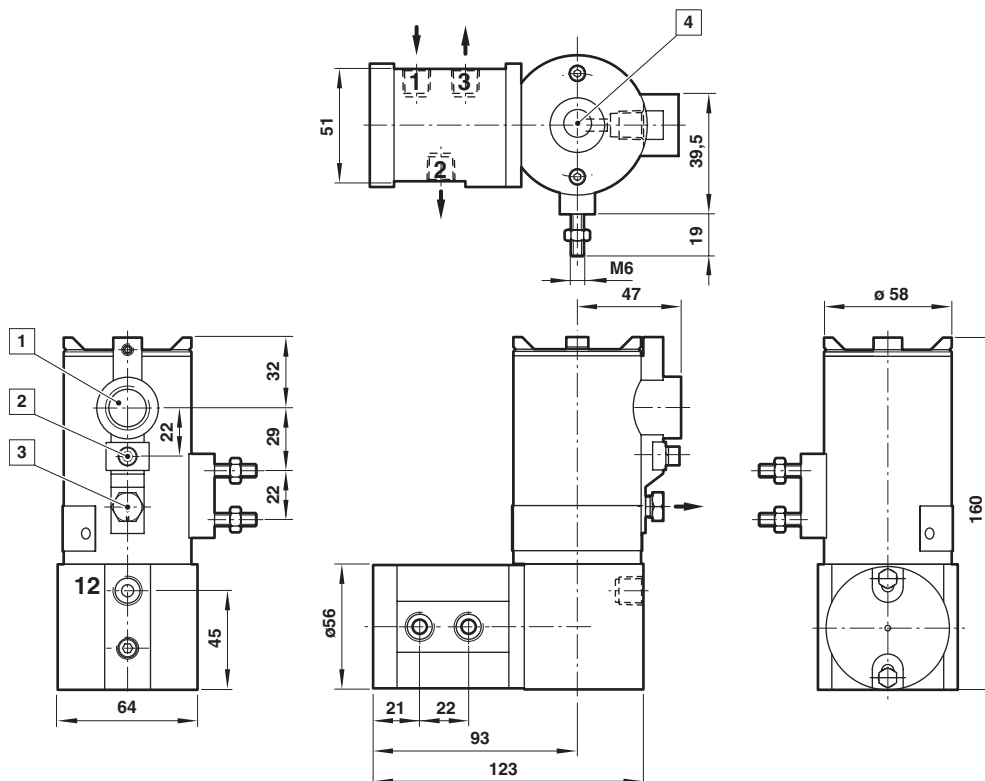

- 1 Conduit connection M20 x 1,5 or 1/2 NPT
- 2 External earth
- 3 Pilot exhaust plugged
- 4 Manual reset (PBMR)

9

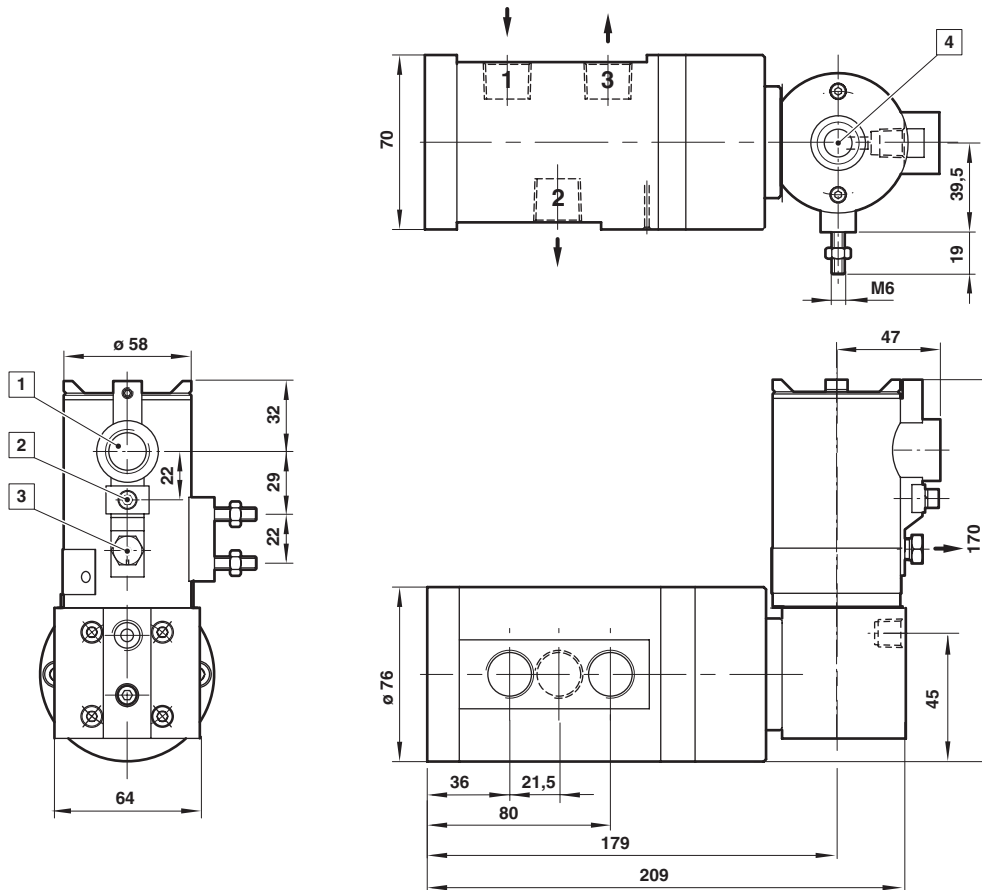

Dimensions in mm
Projection/First angle



10

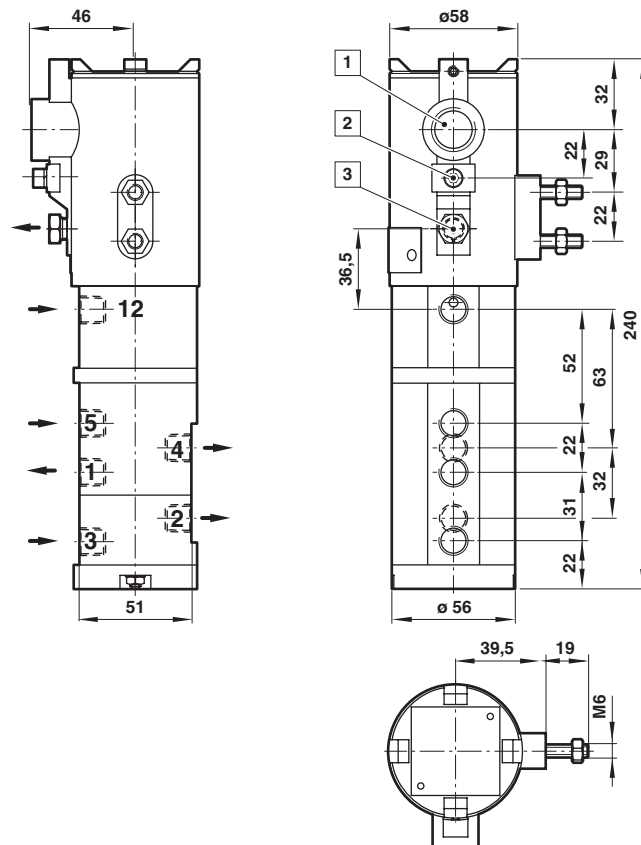

- 1 Conduit connection M20 x 1,5 or 1/2 NPT
- 2 External earth
- 3 Pilot exhaust plugged
- 4 Manual reset (PBMR)

Authorised Distributor:

46, Jalan SS 22/21, Damansara Jaya,
47400 Petaling Jaya,
Selangor Darul Ehsan, Malaysia.

Email: ampmech@ampmech.com

Website: www.ampmech.com

Warning

These products are intended for use in industrial compressed air systems only. Do not use these products where pressures and temperatures can exceed those listed under

»Technical features/data«.

Before using these products with fluids other than those specified, for non-industrial applications, life-support systems or other applications not within published specifications, consult IMI Precision Engineering, Thompson Valves Ltd.

Through misuse, age, or malfunction, components used in fluid power systems can fail in various modes.

The system designer is warned to consider the failure modes of all component parts used in fluid power systems and to provide adequate safeguards to prevent personal injury or damage to equipment in the event of such failure.

System designers must provide a warning to end users in the system instructional manual if protection against a failure mode cannot be adequately provided.

System designers and end users are cautioned to review specific warnings found in instruction sheets packed and shipped with these products.