

- > Port size: 1/4" ... 3/4" (ISO G/NPT) or manifold version
- > Direct acting solenoid valve for the control of hydraulic or pneumatic equipment
- > High flow
- > Up to 414 bar inlet pressure
- > Reliable and long life, ideal for a one time installation
- > Certifications: ATEX, CSA, TR CU, NEPSI, KOSHA, IECEX, FM, CRN, CCOE IN-METRO
- > Environmental protection; NEMA 4X, IP66/X8



### Technical features

#### Medium:

Hydraulic and pneumatic – customer to specify and confirm compatibility

#### Operation:

Direct solenoid operated poppet valves

#### Mounting position:

Solenoid vertical

#### Flow:

0,8 Cv (11,5 Kv) ... 5.0 Cv (72.0 Kv)

#### Port size:

1/4 NPT, 1/2 NPT, G1/4, G1/2 or manifold version

#### Operating pressure:

0 ... 20 bar (0 ... 290 psi)  
0 ... 50 bar (0 ... 725 psi)  
0 ... 207 bar (0 ... 3002 psi)  
0 ... 414 bar (0 ... 6004 psi)

#### Temperature:

Media:

-20 ... +90°C (-4 ... +194°F)  
Options to -60°C (-76°F) available on request

Ambient:

See table on page 2  
Air supply must be dry enough to avoid ice formation at temperatures below +2°C (+35°F).

#### Materials:

Valve body, trim, coil housing and top cover:  
stainless steel 1.4404 (316 L)  
Other trim and body materials available

O-rings seats & seals: high NBR

Other seal materials available on request

Technical data – standard models with conduit connection M20 x 1,5

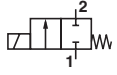
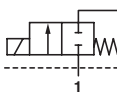
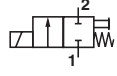
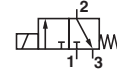
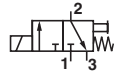
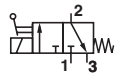
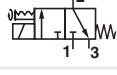
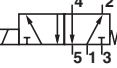
Symbol	Port size	Function	Operating pressure (bar)	Material Seat seal	Manual override/ reset	ATEX certification	Power consumption 24 V d.c. (W)	Ambient temperature	Weight (kg)	Dimension No.	Model
	1/4 NPT	2/2 NC	0 ... 20	NBR	Without	Exd IIC T6	4,5	T6 (-60 ... +48°C), T4 (-60 ... +90°C)	5	1	Y121AA1H1*S
	G 1/4	2/2 NC	0 ... 20	NBR	Without	Exd IIC T6	4,5	T6 (-60 ... +48°C), T4 (-60 ... +90°C)	5	1	Y121AE1H1*S
	1/2 NPT	2/2 NC	0 ... 50	NBR	Without	Exd IIC T6	9,6	T6 (-60 ... +48°C), T4 (-60 ... +90°C)	7,5	2	Y131AA3H1*S
	G 1/2	2/2 NC	0 ... 50	NBR	Without	Exd IIC T6	9,6	T6 (-60 ... +48°C), T4 (-60 ... +90°C)	7,5	2	Y131AE3H1*S
	1/2 NPT	2/2 NC	30 ... 414	NBR	Without	Exd IIC T6	15,1	T6 (-60 ... +48°C), T4 (-60 ... +90°C)	7,5	3	Y191AA3J1*S
	G 1/2	2/2 NC	30 ... 414	NBR	Without	Exd IIC T6	15,1	T6 (-60 ... +48°C), T4 (-60 ... +90°C)	7,5	3	Y191AE3J1*S
	3/4 NPT	2/2 NC	0 ... 12	NBR	Without	Exd IIC T6	15,1	T6 (-60 ... +48°C), T4 (-60 ... +90°C)	10	4	Y113AA5H1*S
	G 3/4	2/2 NC	0 ... 12	NBR	Without	Exd IIC T6	15,1	T6 (-60 ... +48°C), T4 (-60 ... +90°C)	10	4	Y113AE5H1*S
	Manifold	2/2 NC	0 ... 207	NBR	Without	Exd IIC T6	9,6	T6 (-60 ... +48°C), T4 (-60 ... +90°C)	6	5	Y161AKFJ1*S
	Manifold	2/2 NC	0 ... 414	NBR	Without	Exd IIC T6	9,6	T6 (-60 ... +48°C), T4 (-60 ... +90°C)	6	5	Y191AKFJ1*S
	1/4 NPT	2/2 NC	0 ... 20	NBR	PBMR*	Exd IIC T6	4,5	T6 (-60 ... +48°C), T4 (-60 ... +90°C)	5,5	6	Y121PA1H1*S
	G 1/4	2/2 NC	0 ... 20	NBR	PBMR*	Exd IIC T6	4,5	T6 (-60 ... +48°C), T4 (-60 ... +90°C)	5,5	6	Y121PE1H1*S
	1/2 NPT	2/2 NC	0 ... 20	NBR	PBMR*	Exd IIC T6	4,5	T6 (-60 ... +48°C), T4 (-60 ... +90°C)	7,5	7	Y121PA3H1*S
	G 1/2	2/2 NC	0 ... 20	NBR	PBMR*	Exd IIC T6	4,5	T6 (-60 ... +48°C), T4 (-60 ... +90°C)	7,5	7	Y121PE3H1*S
	1/4 NPT	3/2 UNI	0 ... 20	NBR	Without	Exd IIC T6	4,5	T6 (-60 ... +48°C), T4 (-60 ... +90°C)	5,5	8	Y123AA1H1*S
	G 1/4	3/2 UNI	0 ... 20	NBR	Without	Exd IIC T6	4,5	T6 (-60 ... +48°C), T4 (-60 ... +90°C)	5,5	8	Y123AE1H1*S
	1/2 NPT	3/2 UNI	0 ... 20	NBR	Without	Exd IIC T6	9,6	T6 (-60 ... +48°C), T4 (-60 ... +90°C)	7,5	9	Y123AA3H1*S
	G 1/2	3/2 UNI	0 ... 20	NBR	Without	Exd IIC T6	9,6	T6 (-60 ... +48°C), T4 (-60 ... +90°C)	7,5	9	Y123AE3H1*S
	3/4 NPT	3/2 UNI	0 ... 12	NBR	Without	Exd IIC T6	15,1	T6 (-60 ... +48°C), T4 (-60 ... +90°C)	10	10	Y113AA5H1*S
	G 3/4	3/2 UNI	0 ... 12	NBR	Without	Exd IIC T6	15,1	T6 (-60 ... +48°C), T4 (-60 ... +90°C)	10	10	Y113AE5H1*S
	1/4 NPT	3/2 UNI	0 ... 20	NBR	PBMR*	Exd IIC T6	4,5	T6 (-60 ... +48°C), T4 (-60 ... +90°C)	5,5	11	Y123PA1H1*S
	G 1/4	3/2 UNI	0 ... 20	NBR	PBMR*	Exd IIC T6	4,5	T6 (-60 ... +48°C), T4 (-60 ... +90°C)	5,5	11	Y123PE1H1*S
	1/2 NPT	3/2 UNI	0 ... 20	NBR	PBMR*	Exd IIC T6	6,0	T6 (-60 ... +48°C), T4 (-60 ... +90°C)	7,5	12	Y123PA3H1*S
	G 1/2	3/2 UNI	0 ... 20	NBR	PBMR*	Exd IIC T6	6,0	T6 (-60 ... +48°C), T4 (-60 ... +90°C)	7,5	12	Y123PE3H1*S
	1/4 NPT	3/2 UNI	0 ... 20	NBR	A-L-L*	Exd IIC T6	4,5	T6 (-60 ... +48°C), T4 (-60 ... +90°C)	5,5	13	Y123BA1H1*S
	G 1/4	3/2 UNI	0 ... 20	NBR	A-L-L*	Exd IIC T6	4,5	T6 (-60 ... +48°C), T4 (-60 ... +90°C)	5,5	13	Y123BE1H1*S
	1/2 NPT	3/2 UNI	0 ... 20	NBR	A-L-L*	Exd IIC T6	15,1	T6 (-60 ... +48°C), T4 (-60 ... +90°C)	7,5	14	Y123BA3H1*S
	G 1/2	3/2 UNI	0 ... 20	NBR	A-L-L*	Exd IIC T6	15,1	T6 (-60 ... +48°C), T4 (-60 ... +90°C)	7,5	14	Y123BE3H1*S
	1/4 NPT	3/2 UNI	0 ... 20	NBR	JSMO*	Exd IIC T6	4,5	T6 (-60 ... +48°C), T4 (-60 ... +90°C)	5,5	15	Y123SA1H1*S
	G 1/4	3/2 UNI	0 ... 20	NBR	JSMO*	Exd IIC T6	4,5	T6 (-60 ... +48°C), T4 (-60 ... +90°C)	5,5	15	Y123SE1H1*S
	1/2 NPT	5/2 UNI	0 ... 12	NBR	Without	Exd IIC T6	7,5	T6 (-60 ... +48°C), T4 (-60 ... +90°C)	7,5	16	Y115AA3H1*S
	G 1/2	5/2 UNI	0 ... 12	NBR	Without	Exd IIC T6	7,5	T6 (-60 ... +48°C), T4 (-60 ... +90°C)	7,5	16	Y115AE3H1*S

\* Insert voltage code - shown in option selector on page 3

Other product and body material available for more information contact Maxseal technical service

PBMR = Push button manual reset, A-L-L = Automatic latching lever, JSMO = Jack screw manual override

**Option selector**
**Y1\*\*\*\*\*S**

Operating pressure	Substitute
0 ... 12 bar (0 ... 175 psi)	<b>1</b>
0 ... 20 bar (0 ... 290 psi)	<b>2</b>
0 ... 50 bar (0 ... 725 psi)	<b>3</b>
0 ... 207 bar (0 ... 3002 psi)	<b>6</b>
0 ... 414 bar	<b>9</b>
Number of ports	Substitute
2 /2 NC (standard)	<b>1</b>
2 /2 NO	<b>2</b>
3/2 NC (universal)	<b>3</b>
5/2	<b>5</b>
Operation	Substitute
Automatic	<b>A</b>
Automatic latching lever	<b>B</b>
Push button manual override	<b>C</b>
Lever manual reset (414 bar only)	<b>L</b>
Lever manual override (414 bar only)	<b>M</b>
Push button manual reset	<b>P</b>
Jack screw manual override	<b>S</b>
Tamper proof manual reset	<b>T</b>
Port size	Substitute
1/4 NPT	<b>A1</b>
G 1/4	<b>E1</b>
1/2 NPT	<b>A3</b>
G 1/2	<b>E3</b>
3/4 NPT	<b>A5</b>
G 3/4	<b>E5</b>
Manifold	<b>KF</b>

Voltage	Substitute
18 /33 V d.c.	<b>A</b>
24 V d.c.	<b>B</b>
48 /50 V d.c. (50 V)	<b>C</b>
110 V d.c.	<b>D</b>
125 V d.c.	<b>E</b>
220 /240 V d.c. (240 V)	<b>F</b>
24 V a.c.	<b>G</b>
110 V a.c.	<b>J</b>
12 V d.c.	<b>L</b>
220 /240 V a.c. (240 V)	<b>M</b>
Conduit connection	Substitute
M20 x 1.5 mm	<b>1</b>
1/2 NPT	<b>2</b>
Seat /seal material	Substitute
High Nitrile (standard)	<b>H</b>
FKM	<b>V</b>





5

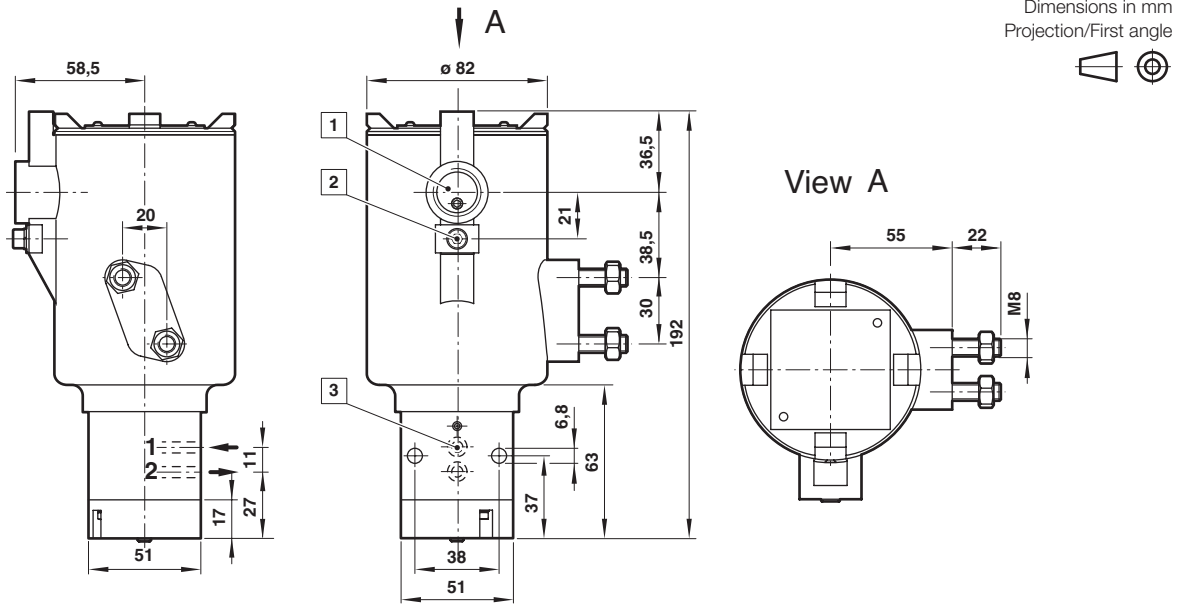

6

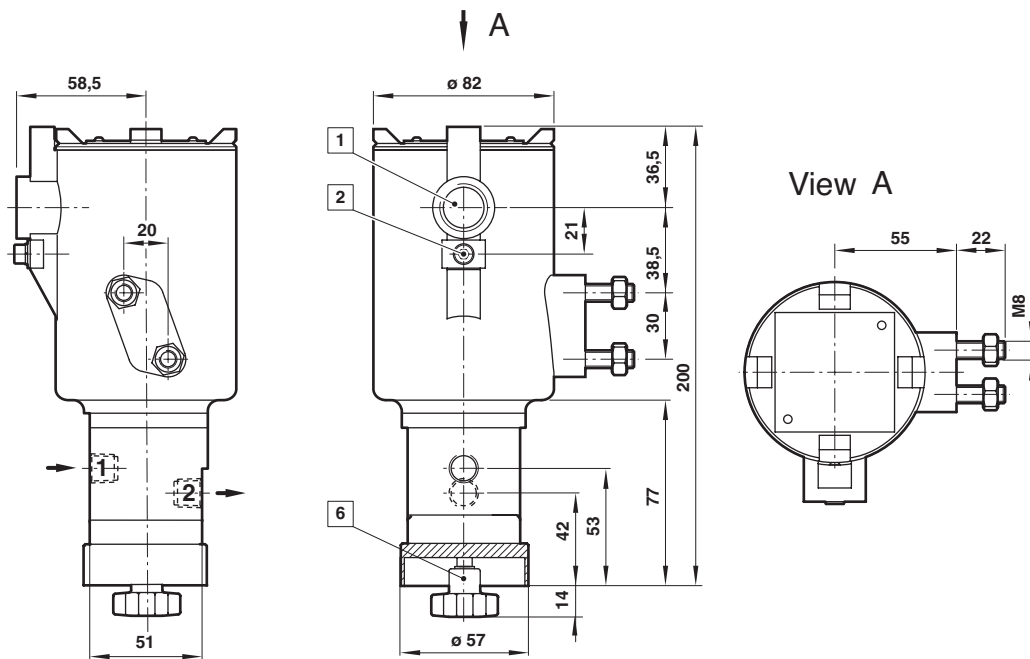

- 1 Conduit connection M20 x 1,5 or 1/2 NPT
- 2 External earth
- 3  $\varnothing 5$  mm drilled ports supplied with O-rings
- 6 Push button manual reset

7

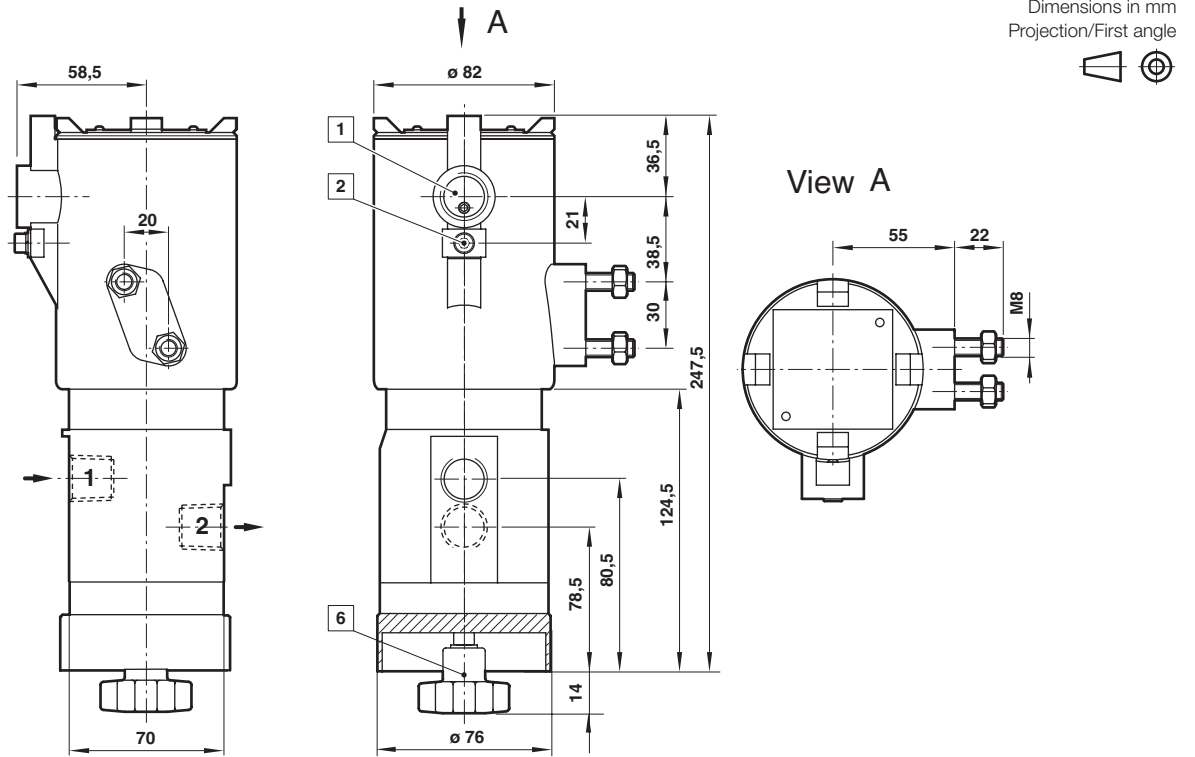

8

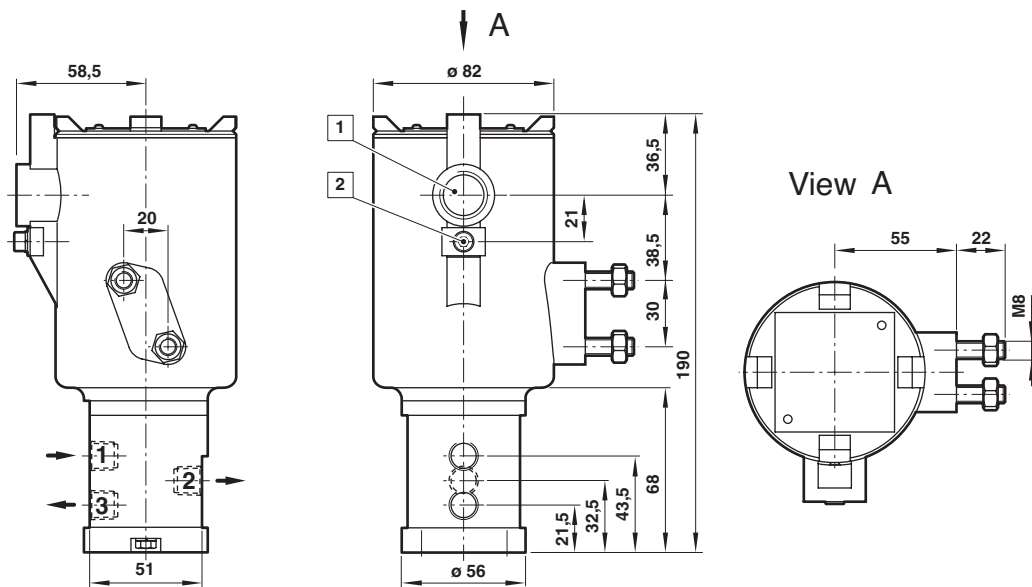

- 1 Conduit connection M20 x 1,5 or 1/2 NPT
- 2 External earth
- 6 Push button manual reset

9

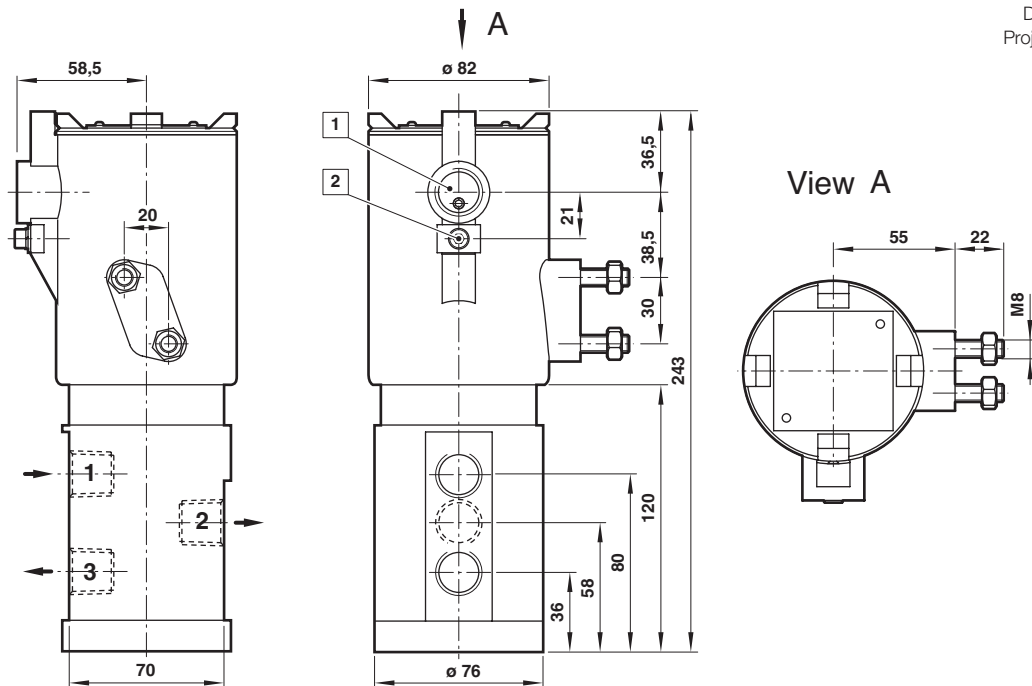

Dimensions in mm  
Projection/First angle



10

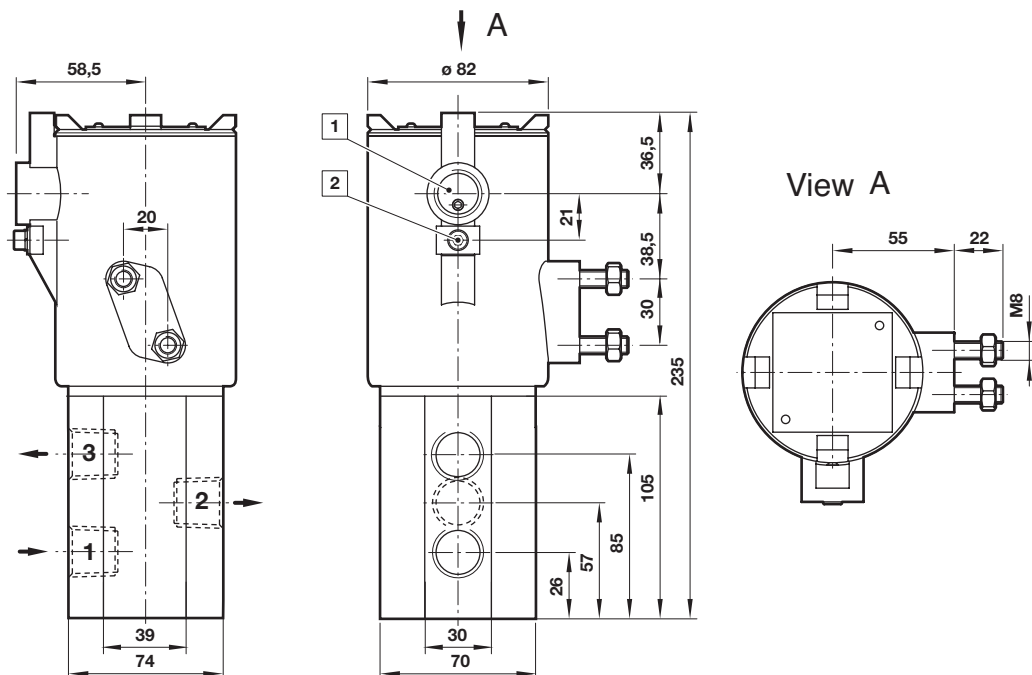

- 1 Conduit connection M20 x 1,5 or 1/2 NPT
- 2 External earth

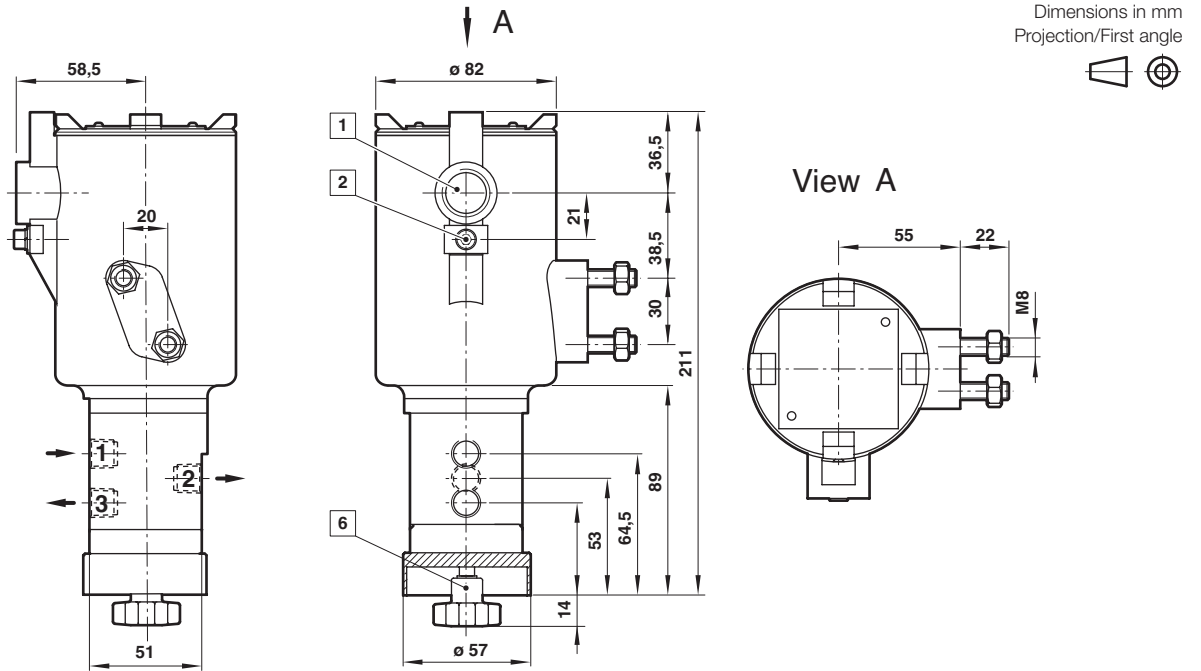
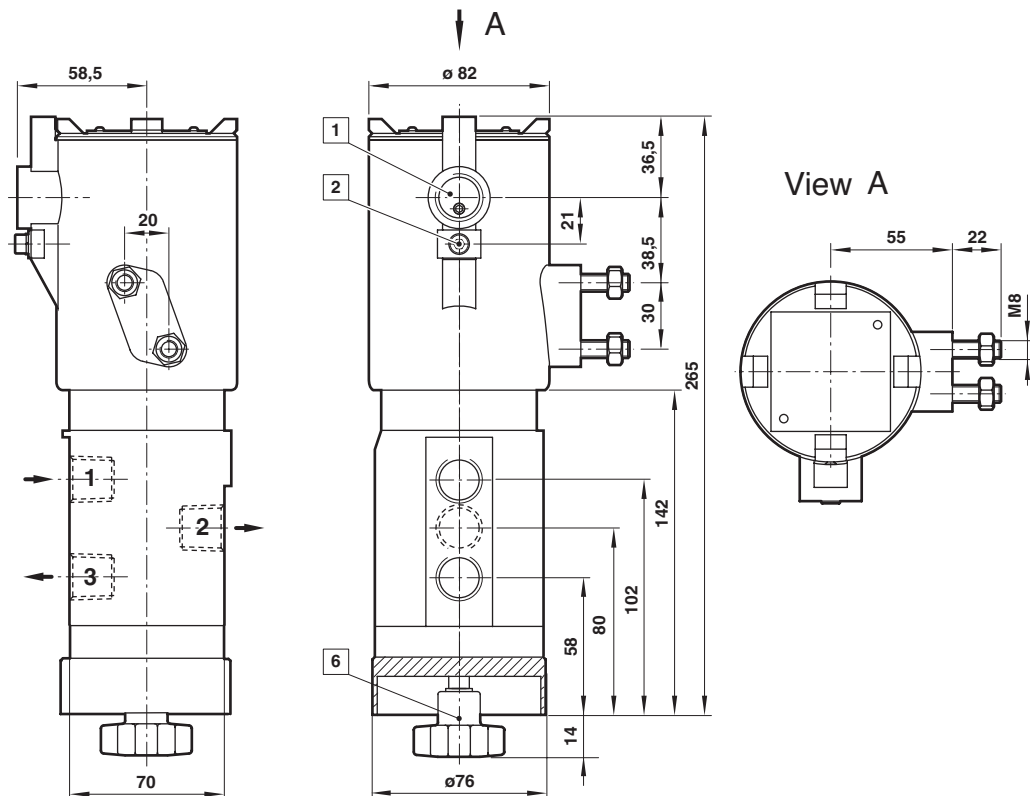
**11**

**12**

- 1 Conduit connection M20 x 1,5 or 1/2 NPT
- 2 External earth
- 6 Push button manual reset

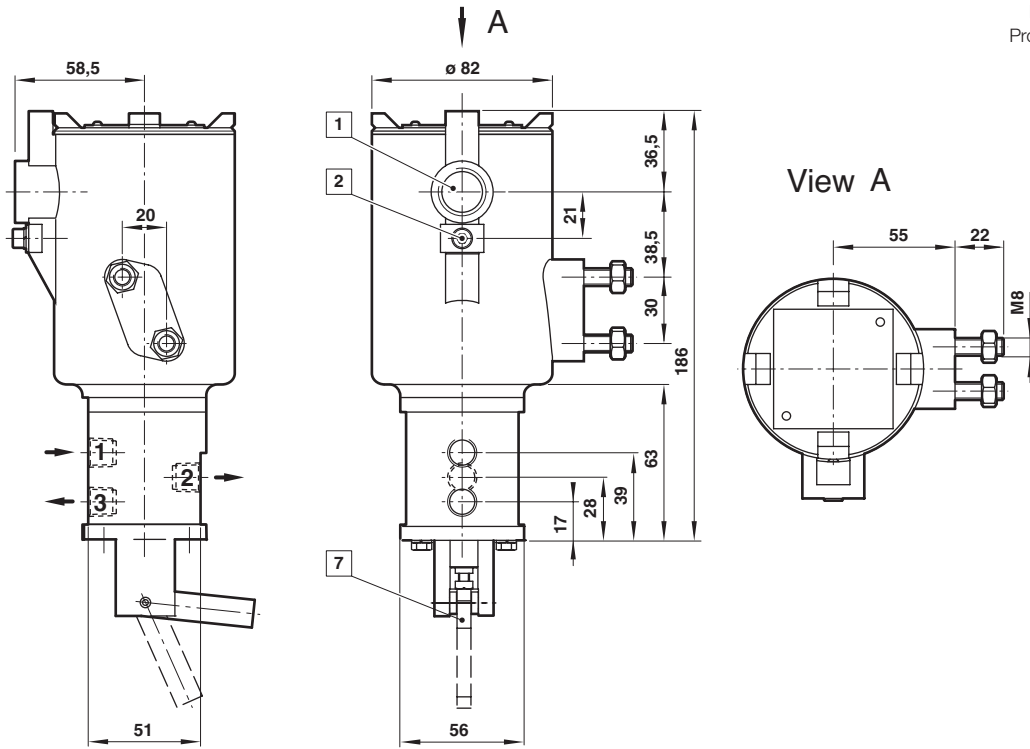
13

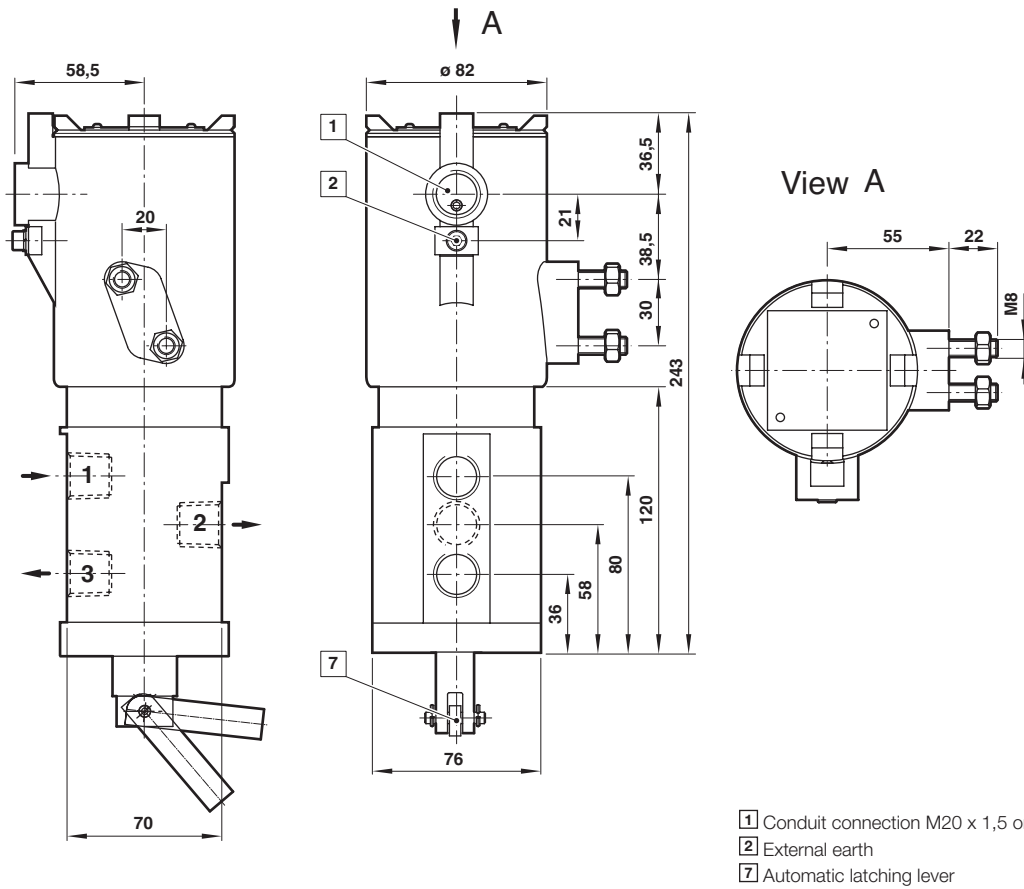

14



- 1 Conduit connection M20 x 1,5 or 1/2 NPT
- 2 External earth
- 7 Automatic latching lever

15

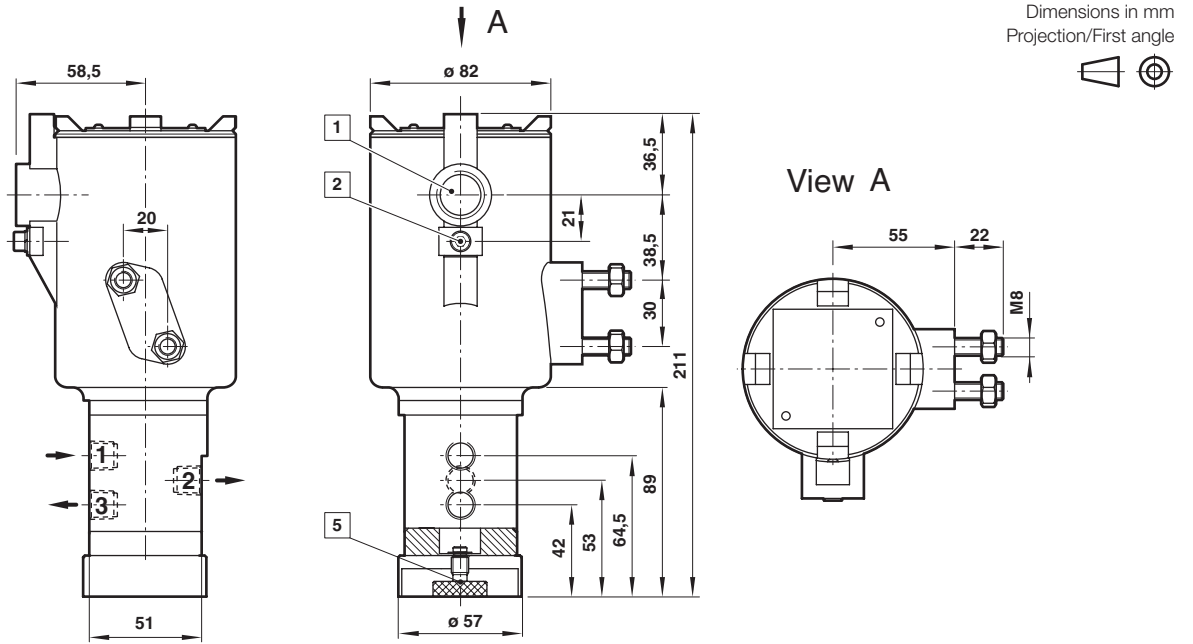

16

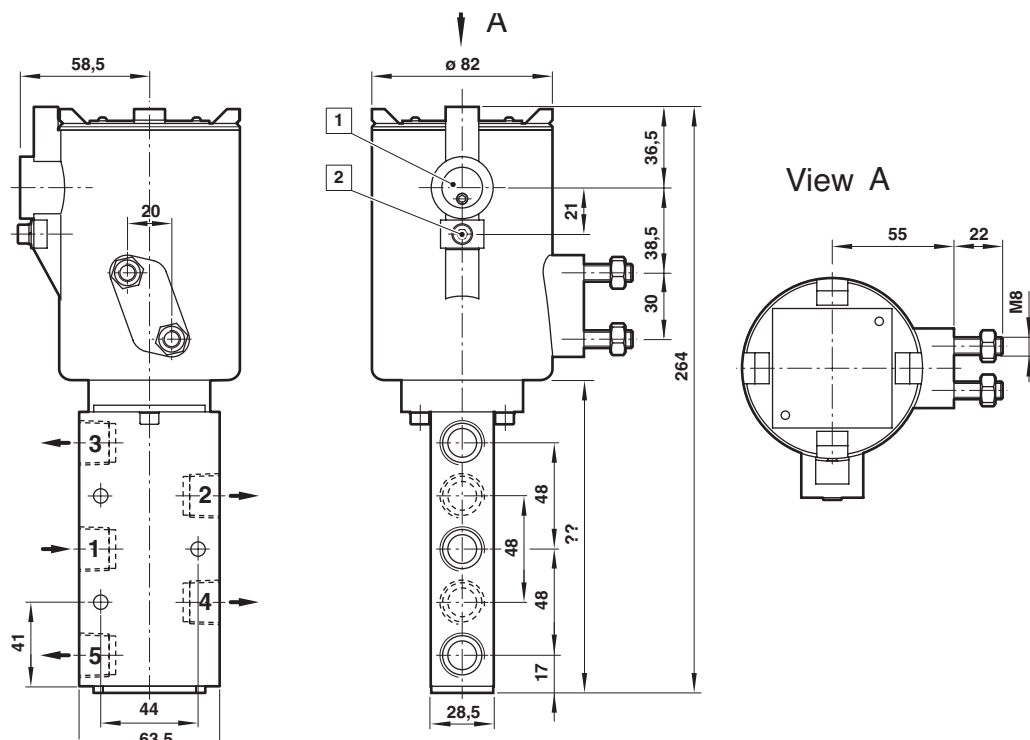

- 1 Conduit connection M20 x 1,5 or 1/2 NPT
- 2 External earth
- 5 Jack screw manual override

## Warning

These products are intended for use in industrial compressed air systems only. Do not use these products where pressures and temperatures can exceed those listed under

»**Technical features/data**«.

Before using these products with fluids other than those specified, for non-industrial applications, life-support systems or other applications not within published specifications, consult IMI Precision Engineering, Thompson Valves Ltd.

Through misuse, age, or malfunction, components used in fluid power systems can fail in various modes.

The system designer is warned to consider the failure modes of all component parts used in fluid power systems and to provide adequate safeguards to prevent personal injury or damage to equipment in the event of such failure.

System designers must provide a warning to end users in the system instructional manual if protection against a failure mode cannot be adequately provided.

System designers and end users are cautioned to review specific warnings found in instruction sheets packed and shipped with these products.

**Authorised Distributor:**



46, Jalan SS 22/21, Damansara Jaya,  
47400 Petaling Jaya,  
Selangor Darul Ehsan, Malaysia.

*Email: [ampmech@ampmech.com](mailto:ampmech@ampmech.com)*

*Website: [www.ampmech.com](http://www.ampmech.com)*