

Rosemount™ 3051S Pressure Transmitter

High accuracy pressure measurement
for tank gauging systems



- Enable online mass and density calculation – no need for manual density sampling
- Use it in all storage applications, including crude oil tanks, pressurized tanks, and tanks with/without floating roofs
- Benefit from convenient and safe installation with two-wire IS bus power supply
- Measure with industry-leading 0.025% pressure accuracy and density according to API chapter 3.6
- Includes a wireless version utilizing a long-life IS power module

Note

For the general Rosemount 3051S Product Data Sheet, see [Rosemount 3051S Series of Instrumentation](#).

Rosemount 3051S Pressure Transmitter in tank gauging applications

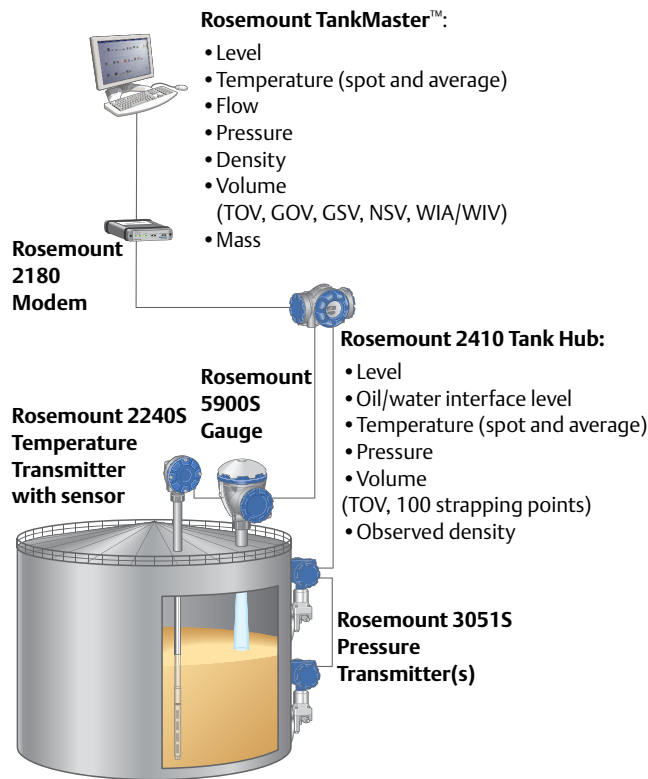

A Rosemount Tank Gauging system configuration including level, temperature, and pressure measurement instruments for high-performance mass, density, volume, and level gauging



Rosemount 3051S Wireless Scalable™ Pressure Transmitter

Get online mass and density measurement

Enhance your bulk liquid measurement and eliminate the need for manual sampling. By complementing the high-accuracy level measurement with high-performance temperature and pressure measurement, the density and mass of the product in the tank as well as the net volume can be continuously calculated.

Rosemount 3051S is the standard pressure transmitter for Rosemount Tank Gauging Systems:

- One or several pressure transmitters per tank can be used for liquid and vapor pressure.
- The state-of-the-art pressure accuracy gives the highest density precision.
- The Rosemount 3051S supplies pressure data to the self-configured FOUNDATION™ Fieldbus communication-based Tankbus.

The Rosemount 3051S Series consists of transmitters and flanges suitable for all kinds of applications, including crude oil tanks and tanks with/without floating roofs.

The Rosemount 3051S is also available as a wireless device, which can be used in an IEC 62591 (*WirelessHART*®) network. It is powered by a long-life intrinsically safe power module, and has the same outstanding performance as the wired version.

For more information, see the product data sheets for [Rosemount 3051S](#), [Rosemount 5900S](#), [Rosemount 2240S](#), and [Rosemount 565/566/765](#).

Contents

Ordering information	3	Product certifications	12
Specifications	10	Dimensional drawings	18

Ordering information

Rosemount 3051S Coplanar™ Pressure Transmitter



The Rosemount 3051S Coplanar Pressure Transmitters are the industry leaders for differential, gage, and absolute pressure measurement.

Used for density measurement on non-viscous liquids such as diesel and vapor pressure measurement. The capabilities include:

- Ultra and Classic Performance
- Wireless and FOUNDATION Fieldbus protocols
- Safety certification (option code QT)

Additional information

Specifications: [page 10](#)

Dimensional drawings: [page 18](#)

This section includes a selection of Rosemount pressure transmitter products and options. For complete information, see the [Rosemount 3051S Product Data Sheet](#).

Table 1. Rosemount 3051S Coplanar Pressure Transmitter Ordering Information

★ The standard offering represents the most common options. The starred options (★) should be selected for best delivery. The expanded offering is subject to additional delivery lead time.

Model	Product description	
3051S	Scalable Pressure Transmitter	
Performance class		
1	Ultra: 0.025% span accuracy, 200:1 rangedown, 15-year stability, 15-year limited warranty	★
2	Classic: 0.035% span accuracy, 150:1 rangedown, 15-year stability	★
Connection type		
C	Coplanar	★
Measurement type		
G	Gage	★
Pressure range		
1A ⁽¹⁾	-25 to 25 inH ₂ O (-62.16 to 62.16 mbar)	★
2A ⁽¹⁾	-250 to 250 inH ₂ O (-621.60 to 621.60 mbar)	★
3A ⁽²⁾	-393 to 1000 inH ₂ O (-0.97 to 2.48 bar)	★
Isolating diaphragm		
2	316L SST	★
Process connection		
Connection for Vapor Pressure Transmitter (SST/316 SST)		
E12	Coplanar flange, ¼ - 18 NPT	★
Vertical mount ANSI flanges (SST/316 SST)		
G11	2-in. (51-mm) Class 150	★
G12	2-in. (51-mm) Class 300	★

Table 1. Rosemount 3051S Coplanar Pressure Transmitter Ordering Information

★ The standard offering represents the most common options. The starred options (★) should be selected for best delivery. The expanded offering is subject to additional delivery lead time.

G21	3-in. (76-mm) Class 150	★
G22	3-in. (76-mm) Class 300	★
Vertical mount EN flanges (SST/316 SST)		
G31	DN50 PN40	★
G41	DN80 PN40	★
Transmitter output		
F ⁽³⁾	Bus-powered two-wire FOUNDATION Fieldbus (IEC 61158)	★
A	4-20 mA with digital signal based on HART® protocol	★
X ⁽⁴⁾	Wireless (requires wireless options and wireless PlantWeb housing)	★
Housing style		
1A	PlantWeb™ housing (aluminum), ½-14 NPT	★
1B	PlantWeb housing (aluminum), M20 x 1.5	★
2A	Junction box housing (aluminum), ½-14 NPT	★
2B	Junction box housing (aluminum), M20 x 1.5	★
5A ⁽⁵⁾	Wireless PlantWeb housing (aluminum), ½-14 NPT	★
Wireless options⁽⁶⁾		
Update rate, operating frequency, and protocol		
WA3	User-configurable update rate, 2.4 GHz DSSS, IEC 62591 (WirelessHART)	★
Omni-directional wireless antenna and SmartPower™		
WK1	External antenna, adapter for black power module (I.S. power module sold separately)	★
WM1	Extended range, external antenna, adapter for black power module (I.S. power module sold separately)	★
Other options – none or multiple selections are possible		
Product certifications		
IA ⁽⁷⁾	ATEX FISCO intrinsic safety	★
IE ⁽⁷⁾	FM FISCO intrinsically safe	★
IF ⁽⁷⁾	CSA FISCO intrinsically safe	★
IG ⁽⁷⁾	IECEX FISCO intrinsic safety	★
IB ⁽⁷⁾	INMETRO FISCO intrinsic safety	★
I1	ATEX intrinsic safety	★
I5	FM intrinsically safe, Nonincendive	★
I6	CSA intrinsically safe	★
I7	IECEX intrinsic safety	★
E1	ATEX flameproof	★
E5	FM explosion-proof, dust ignition-proof	★

Table 1. Rosemount 3051S Coplanar Pressure Transmitter Ordering Information

★ The standard offering represents the most common options. The starred options (★) should be selected for best delivery. The expanded offering is subject to additional delivery lead time.

E6 ⁽⁸⁾	CSA explosion-proof, dust ignition-proof, division 2	★
E7	IECEX flameproof, dust ignition-proof	★
IM	Technical Regulations Customs Union (EAC) intrinsic safety	
Other		
L4	Austenitic 316 SST bolts	★
M5	PlantWeb LCD display	★
P1	Hydrostatic testing with certificate	
Q4	Calibration certificate	★
Q8	Material traceability certification per EN 10204 3.1	★
GE ⁽⁹⁾	M12, 4-pin, male connector (eurofast®)	★
GM ⁽⁹⁾	A size Mini, 4-pin, male connector (minifast®)	★
WR3	3-year limited warranty	
WR5	5-year limited warranty	
Typical Model Number: 3051S - 1 C G 3A 2 G11 F 1A - IA Q4		

- For vapor pressure measurement (P3).
- For liquid pressure measurement (P1).
- Requires PlantWeb housing.
- Only intrinsically safe approval codes apply.
- Only available with output code X.
- Requires transmitter output code X and wireless PlantWeb housing. Also see section for Hazardous Location Certification.
- For use with Rosemount 2410 Tank Hub. FOUNDATION Fieldbus protocol only.
- Not available with M20 or G ½ conduit entry size.
- Not available with Housing code 00, 5A, 5J, or 7J. Available with intrinsically safe approvals only. For FM intrinsically safe; nonincendive (option code I5) or FM FISCO intrinsically safe (option code IE), install in accordance with Rosemount drawing 03151-1009. Suitable for use with all IS approvals (I1, I2, I3, I5, I6, I7, IA, IB, IE, IF, IG, IP, IM, KG).

Rosemount 3051S Liquid Level Pressure Transmitter



Used for density measurement of viscous liquids such as crude oil.

- Integrated transmitter and direct mount seal in a single model number
- Variety of process connections including flanged, threaded, and hygienic direct mount seals
- FOUNDATION Fieldbus and wireless protocols
- Safety certification (option code QT)

Additional information

Specifications: [page 10](#)

Dimensional drawings: [page 18](#)

This section includes a selection of Rosemount pressure transmitter products and options. For complete information, see the [Rosemount 3051S Product Data Sheet](#).

Table 2. Rosemount 3051S Liquid Level Pressure Transmitter Ordering Information

★ The standard offering represents the most common options. The starred options (★) should be selected for best delivery. The expanded offering is subject to additional delivery lead time.

Model	Product description	
3051SAL	Scalable Level Transmitter	
Performance class		
1	Ultra: 0.055% span accuracy, 150:1 rangedown, 15-year limited warranty	★
2	Classic: 0.065% span accuracy, 150:1 rangedown	★
Configuration type		
C	Liquid Level Transmitter	★
Pressure module type and pressure sensor type		
G	Coplanar module, gage sensor	★
Pressure range		
3A	-393 to 1000 inH ₂ O (-0.97 to 2.48 bar)	★
4A	-14,2 to 300 psig (-0.97 to 20.68 bar)	★
Transmitter output		
F ⁽¹⁾	Bus-powered two-wire FOUNDATION Fieldbus (IEC61158)	★
A	4-20 mA with digital signal based on HART protocol	★
X ⁽²⁾	Wireless (requires wireless options and wireless PlantWeb housing)	★
Housing style		
1A	PlantWeb housing (aluminum), ½-14 NPT	★
1B	PlantWeb housing (aluminum), M20 x 1.5	★
2A	Junction box housing (aluminum), ½-14 NPT	★
2B	Junction box housing (aluminum), M20 x 1.5	★
5A ⁽³⁾	Wireless PlantWeb housing (aluminum), ½-14 NPT	★

Table 2. Rosemount 3051S Liquid Level Pressure Transmitter Ordering Information

★ The standard offering represents the most common options. The starred options (★) should be selected for best delivery. The expanded offering is subject to additional delivery lead time.

Direct mount extension (between transmitter flange and seal)				
10	No extension			
Transmitter reference pressure connection				
20	316 L SST isolator with SST transmitter flange			★
Seal fill fluid				
D	Silicone 200, -45 to 205 °C (-49 to 401 °F)			★
Process connection type				
FF	Flush flanged seal			
Process connection size				
G	2 in. (51 mm)/DN50/50 A			★
7	3 in. (76 mm)/80 A			★
J	DN 80			★
9	4 in. (102 mm)/DN 100/100 A			★
Flange/pressure rating				
1	ANSI/ASME B16.5 Class 150			★
2	ANSI/ASME B16.5 Class 300			★
E	PN 10/16 per EN 1092-1, (DN100 only)			
G	PN 40 per EN 1092-1			★
Materials of construction				
	Isolating diaphragm	Upper housing	Flange	
DA	316L SST	316L SST	316 SST	★
Flushing connection ring (lower housing)				
0	None			★
A	316 SST			★
Flushing connection quantity and size				
0	None			★
1	One ¼-18 NPT flushing connection, 1/8-in / 2.5 mm			
3	Two ¼-18 NPT flushing connections, 3/8-in / 7.5 mm			★

Table 2. Rosemount 3051S Liquid Level Pressure Transmitter Ordering Information

★ The standard offering represents the most common options. The starred options (★) should be selected for best delivery. The expanded offering is subject to additional delivery lead time.

Other options – none or multiple selections are possible		
Flushing connection ring plugs		
SG	SST plug(s) for flushing connection(s)	★
Wireless options⁽⁴⁾		
Update rate, operating frequency, and protocol		
WA3	User-configurable update rate, 2.4 GHz DSSS, IEC 62591(<i>WirelessHART</i>)	★
Omni-directional wireless antenna		
WK1	External antenna, adapter for black power module (I.S. power module sold separately)	★
WM1	Extended range, external antenna, adapter for black power module (I.S. power module sold separately)	★
Product certifications		
IA ⁽⁵⁾	ATEX FISCO intrinsic safety	★
IE ⁽⁵⁾	FM FISCO intrinsic safety	★
IF ⁽⁵⁾	CSA FISCO intrinsic safety	★
IG ⁽⁵⁾	IECEX FISCO intrinsic safety	★
IB ⁽⁵⁾	INMETRO FISCO intrinsic safety	★
I1	ATEX intrinsic safety	★
I2	INMETRO intrinsic safety	★
I5	FM intrinsically safe; nonincendive	★
I6	CSA intrinsically safe	★
I7	IECEX intrinsic safety	★
E1	ATEX flameproof	★
E5	FM explosion-proof, dust ignition-proof	★
E6	CSA explosion-proof, dust ignition-proof, division 2 (Not available with M20 or G ½ conduit entry size.)	★
E7	IECEX flameproof, dust ignition-proof	★
IM	Technical Regulations Customs Union (EAC) intrinsic safety	

Table 2. Rosemount 3051S Liquid Level Pressure Transmitter Ordering Information

★ The standard offering represents the most common options. The starred options (★) should be selected for best delivery. The expanded offering is subject to additional delivery lead time.

Other		
L4	Austenitic 316 SST bolts	★
M5	PlantWeb LCD display	★
P1	Hydrostatic testing with certificate	
Q4	Calibration certificate	★
Q8	Material traceability certification per EN 10204 3.1	★
GE ⁽⁶⁾	M12, 4-pin, male connector (eurofast)	★
GM ⁽⁶⁾	A size Mini, 4-pin, male connector (minifast)	★
WR3	3-year limited warranty	
WR5	5-year limited warranty	
Typical Model Number: 3051SAL - 2 C G 3A F 1A 10 20 D FF G 1 DA 0 0-IA Q4		

- Requires PlantWeb housing.
- Only intrinsically safe approval codes apply.
- Only available with output code X.
- Requires transmitter output code X and housing style code 5A. Also see section for Hazardous Location Certification.
- For use with Rosemount 2410 Tank Hub (FOUNDATION Fieldbus protocol only).
- Not available with housing style code 5A, 5J, or 7J. Available with intrinsically safe approvals only. For FM intrinsically safe, nonincendive (option code I5) or FM FISCO intrinsically safe (option code IE), install in accordance with Rosemount drawing 03151-1009.

Specifications

Rosemount 3051S Pressure Transmitter:

- Coplanar Pressure Transmitter
- Liquid Level Pressure Transmitter

For complete information and offering, see the [Rosemount 3051S Product Data Sheet](#).

Performance specifications

Reference accuracy

Coplanar pressure transmitter: up to $\pm 0.025\%$ of span for ultra version, up to $\pm 0.035\%$ of span for classic version

Liquid level pressure transmitter: up to $\pm 0.055\%$ of span for ultra version, up to $\pm 0.065\%$ of span for classic version

Vibration effect

Less than $\pm 0.1\%$ of URL when tested per the requirements of IEC60770-1 field or pipeline with high vibration level (10-60 Hz 0.21 mm displacement peak amplitude/60-2000 Hz 3g).

Transient protection (option T1)

Tested in accordance with IEEE C62.41.2-2002, Location Category B
 6 kV crest (0.5 μ s - 100 kHz)
 3 kA crest (8 x 20 microseconds)
 6 kV crest (1.2 x 50 microseconds)

Electromagnetic compatibility (EMC)

Meets all relevant requirements of EN 61326 and NAMUR NE-21.⁽¹⁾

Functional specifications

Pressure range

-393 to 1000 inH₂O (-0.98 to 2.5 bar)
 1000 inH₂O \Leftrightarrow 25 mH₂O

FOUNDATION Fieldbus

Power supply

Powered by Rosemount 2410 Tank Hub

Bus current draw

17.5 mA

Class (basic or link master)

The transmitter can function as a backup Link Active Scheduler (LAS) if the current link master device fails or is removed from the segment.

Standard blocks and execution time

Block	Execution time
Resource	N/A
Transducer	N/A
LCD Block	N/A
Analog Input 1, 2	20 milliseconds
PID with Auto-tune	35 milliseconds
Input Selector	20 milliseconds
Arithmetic	20 milliseconds
Signal Characterizer	20 milliseconds
Integrator	20 milliseconds
Output Splitter	20 milliseconds
Control Selector	20 milliseconds

PlantWeb alerts

Yes

IEC 62591 (WirelessHART)

Output

IEC 62591 WirelessHART, 2.4 GHz DSSS

Radio frequency power output from antenna

External antenna (WK option): Maximum of 10 mW (10 dBm) EIRP

Extended range, external antenna (WM option): Maximum of 18 mW (12.5 dBm) EIRP

Update rate

User-selectable 1 sec. to 60 min

Power module

Field replaceable, keyed connection eliminates the risk of incorrect installation, intrinsically safe lithium-thionyl chloride power module with polybutadine terephthalate (PTB) enclosure. Ten-year life at one-minute update rate.⁽²⁾

1. NAMUR NE-21 does not apply to transmitter output code X (wireless).

2. Reference conditions are 21 °C (70 °F), and routing data for three additional network devices.
 NOTE: Continuous exposure to ambient temperature limits of -40 °C or +85 °C (-40 °F or +185 °F) may reduce the specified life by less than 20 percent.

Temperature limits

Ambient

-40 to +85 °C (-40 to +185 °F)
With LCD display⁽¹⁾: -40 to +80 °C (-40 to +175 °F)

Storage

-46 to +85 °C (-50 to 185 °F)
With LCD display: -40 to +85 °C (-40 to +185 °F)
With wireless output: -40 to +85 °C (-40 to +185 °F)

Process

Coplanar Pressure Transmitter: -40 to + 149 °C (-40 to + 300 °F)
Liquid Level Pressure Transmitter: -45 to + 205 °C (-49 to + 401 °F)

Humidity limits

0–100% relative humidity

Physical specifications

Electrical connections

½ - 14 NPT and M20 x 1.5 entries for cable glands and conduits

Tankbus cabling

0.5-1.5 mm² (AWG 22-16), twisted shielded pairs

Non-wetted parts

Electronics housing

Low-copper aluminum alloy or CF-8M (Cast 316 SST)
NEMA 4X, IP 66, IP 68 (66 ft (20 m) for 168 hours)

Note: IP 68 is not available with Wireless Output.

Paint for aluminum housing

Polyurethane

Weight

4 to 15 kg (9-33 lbs) including tank connection, depending on transmitter choice

Integral display

Yes

Configuration tools

Field Communicator, AMST[™] Suite, DeltaV[®] or any other DD (Device Description) compatible host system

Tank gauging pressure applications

Pressure transmitters are used in two main configuration alternatives:

- Tank ventilated to atmosphere:
There is one pressure transmitter installed at the bottom of the tank (P_1) to measure liquid pressure (P_L).
- Pressurized, non-ventilated tank (possibly with a vapor recovery system), and blanketed tanks (nitrogen): One pressure transmitter is installed at the bottom of the tank (P_1), and one pressure transmitter is installed at the top (P_3) to measure vapor pressure.
The liquid pressure, $P_L = P_1 - P_3$

The pressure transmitter installed to measure vapor pressure should always be of coplanar type, non-flanged version (E12 in model code).

The pressure transmitter, which measures liquid pressure, should be of either flanged liquid level or coplanar type. The liquid level pressure transmitter is used for crude oil applications, and the coplanar pressure transmitter is used for any other liquid type.

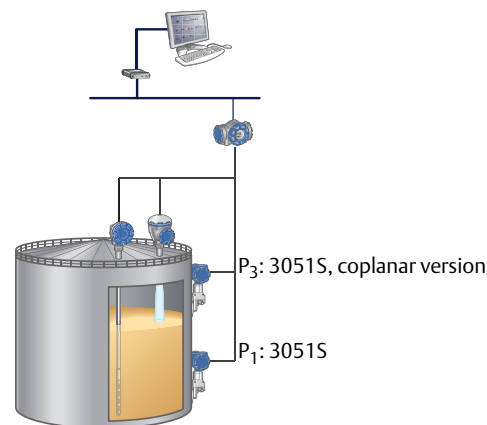

Calibration

Use a T-connection with drain valve, which is necessary for zero calibration of the pressure transmitter installed to measure liquid pressure at the bottom of the tank.

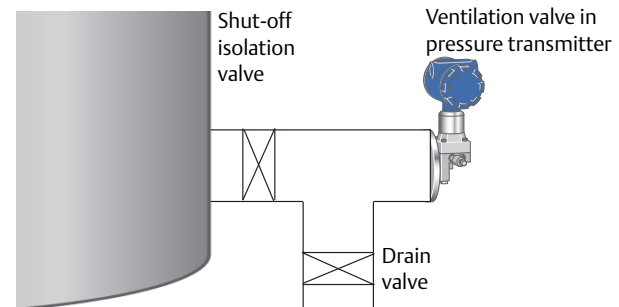

Shut-off isolation and drain valves used for zero calibration of the pressure transmitter.

1. LCD display may not be readable and display updates will be slower at temperatures below -20 °C (-4 °F).

Product certifications

Rev 2.3

Rosemount 3051S Pressure Transmitter:
Coplanar pressure transmitter
Liquid level pressure transmitter

For complete information and offering, see the [Rosemount 3051S Product Data Sheet](#).

Markings:IS CL I, DIV 1, GP A, B, C, D; CL II, DIV 1, GP E, F, G
Class III; Class 1, Zone 0 AEx ia IIC T4; NI CL 1,
DIV 2, GP A, B, C, D; T4(-50 °C ≤ T_a ≤ +70 °C)
[HART]; T4(-50 °C ≤ T_a ≤ +60 °C) [Fieldbus];
when connected per Rosemount drawing
03151-1006; Type 4x

European directive information

A copy of the EC Declaration of Conformity can be found at the end of the Quick Start Guide. The most recent revision of the EU Declaration of Conformity can be found at Emerson.com/Rosemount.

Ordinary location certification

As standard, the transmitter has been examined and tested to determine that the design meets the basic electrical, mechanical, and fire protection requirements by a nationally recognized testing laboratory (NRTL) as accredited by the Federal Occupational Safety and Health Administration (OSHA).

Installing equipment in North America

The US National Electrical Code® (NEC) and the Canadian Electrical Code (CEC) permit the use of Division marked equipment in Zones and Zone marked equipment in Divisions. The markings must be suitable for the area classification, gas, and temperature class. This information is clearly defined in the respective codes.

USA

E5 FM Explosion-Proof (XP) and Dust-Ignition Proof (DIP)

Certificate: FM16US0090

Standards: FM Class 3600 - 2011, FM Class 3615 - 2006, FM Class 3616 - 2011, FM Class 3810 - 2005, ANSI/NEMA 250 - 2003

Markings:XP CL I, DIV 1, GP B, C, D; DIP CL II; DIV 1, GP E, F, G; CL III; T5(-50 °C ≤ T_a ≤ +85 °C);
Factory Sealed; Type 4X

I5 FM Intrinsic Safety (IS) and Nonincendive (NI)

Certificate: FM16US0089X

Standards: FM Class 3600 – 2011, FM Class 3610 – 2010, FM Class 3611 – 2004, FM Class 3810 – 2005, NEMA 250 – 2003

Special conditions for safe use (X):

1. The Model 3051S/3051S-ERS Pressure Transmitter contains aluminum and is considered to constitute a potential risk of ignition by impact or friction. Care must be taken into account during installation and use to prevent impact and friction.

Note

Transmitters marked with NI CL 1, DIV 2 can be installed in Division 2 locations using general Division 2 wiring methods or Nonincendive Field Wiring (NIFW). See Drawing 03151-1006.

IE US FISCO

Certificate: FM16US0089X

Standards: FM Class 3600 – 2011, FM Class 3610 – 2010, FM Class 3611 – 2004, FM Class 3810 – 2005, NEMA 250 – 2003

Markings: S CL I, DIV 1, GP A, B, C, D; (-50 °C ≤ T_a ≤ +60 °C);
when connected per Rosemount drawing
03151-1006; Type 4x

Special conditions for safe use (X):

1. The Model 3051S/3051S-ERS Pressure Transmitter contains aluminum and is considered to constitute a potential risk of ignition by impact or friction. Care must be taken into account during installation and use to prevent impact and friction.

Canada

E6 Canada Explosion-Proof, Dust-Ignition Proof, and division 2

Certificate: 1143113

Standards: CAN/CSA C22.2 No. 0-10, CSA Std C22.2 No. 25-1966, CSA Std C22.2 No. 30-M1986, CAN/CSA C22.2 No. 94-M91, CSA Std C22.2 No. 142-M1987, CSA Std C22.2 No. 213-M1987, ANSI/ISA 12.27.01-2003, CSA Std C22.2 No. 60529:05

Markings: Explosion-proof Class I, Division 1, Groups B, C, D; Dust-Ignitionproof Class II, Division 1, Groups E, F, G; Class III; suitable for Class I, Zone 1, Group IIB+H2, T5; suitable for Class I, Division 2, Groups A, B, C, D; suitable for Class I, Zone 2, Group IIC, T5; when connected per Rosemount drawing 03151-1013; Type 4x

I6 Canada Intrinsically Safe

Certificate: 1143113

Standards: CAN/CSA C22.2 No. 0-10, CSA Std C22.2 No. 30-M1986, CAN/CSA C22.2 No. 94-M91, CSA Std C22.2 No. 142-M1987, CSA Std C22.2 No. 157-92, ANSI/ISA 12.27.01-2003, CSA Std C22.2 No. 60529:05

Markings: Intrinsically Safe Class I, Division 1; Groups A, B, C, D; suitable for Class 1, Zone 0, IIC, T3C; when connected per Rosemount drawing 03151-1016 [3051S] 03151-1313 [ERS]; Type 4X

IF Canada FISCO

Certificate: 1143113

Standards: CAN/CSA C22.2 No. 0-10, CSA Std C22.2 No. 30-M1986, CAN/CSA C22.2 No. 94-M91, CSA Std C22.2 No. 142-M1987, CSA Std C22.2 No. 157-92, ANSI/ISA 12.27.01-2003, CSA Std C22.2 No. 60529:05

Markings: FISCO Intrinsically Safe Class I, Division 1; Groups A, B, C, D; suitable for Class 1, Zone 0, IIC, T3C; when connected per Rosemount drawing 03151-1016 [3051S] 03151-1313 [ERS]; Type 4X

Europe

E1 ATEX Flameproof

Certificate: KEMA 00ATEX2143X

Standards: EN 60079-0:2012+A11:2013, EN 60079-1:2014, EN 60079-26:2015

Markings:  II 1/2 G Ex db IIC T6...T4 Ga/Gb, T6(-60 °C ≤ T_a ≤ +70 °C), T5/T4(-60 °C ≤ T_a ≤ +80 °C)

Temperature class	Process temperature
T6	-60 °C to +70 °C
T5	-60 °C to +80 °C
T4	-60 °C to +120 °C

Special conditions for safe use (X):

1. This device contains a thin wall diaphragm less than 1 mm thickness that forms a boundary between Category 1 (process connection) and Category 2(all other parts of the equipment). The model code and datasheet are to be consulted for details of the diaphragm material. Installation, maintenance and use shall take into account the environmental conditions to which the diaphragm will be subjected. The manufacturer's instructions for installation and maintenance shall be followed in detail to assure safety during its expected lifetime.
2. Flameproof joints are not intended for repair.
3. Non-standard paint options may cause risk from electrostatic discharge. Avoid installations that could cause electrostatic build-up on painted surfaces, and only clean the painted surfaces with a damp cloth. If paint is ordered through a special option code, contact the manufacturer for more information.
4. Appropriate cable, glands and plugs need to be suitable for a temperature of 5°C greater than maximum specified temperature for location where installed.

I1 ATEX Intrinsic Safety

Certificate: BAS01ATEX1303X

Standards: EN 60079-0: 2012+A11:2013, EN 60079-11: 2012

Markings:  II 1 G Ex ia IIC T4 Ga, T4(-60 °C ≤ T_a ≤ +70 °C)

	Ui	Ii	Pi	Ci	Li
SuperModule	30 V	300 mA	1.0 W	30 nF	0
3051S...A; 3051SF...A; 3051SAL...C	30 V	300 mA	1.0 W	12 nF	0
3051S...F; 3051SF...F	30 V	300 mA	1.3 W	0	0
3051S ...A...M7, M8, or M9; 3051SF ...A...M7, M8, or M9; 3051SAL...C... M7, M8, or M9	30 V	300 mA	1.0 W	12 nF	60µH
3051SAL or 3051SAM	30 V	300 mA	1.0 W	12 nF	33µH
3051SAL...M7, M8, or M9 3051SAM...M7, M8, or M9	30 V	300 mA	1.0 W	12 nF	93µH
RTD Option for 3051SF	5 V	500 mA	0.63 W	N/A	N/A

Special conditions for safe use (X):

1. The Model 3051S Transmitters fitted with transient protection are not capable of withstanding the 500 V test as defined in Clause 6.3.13 of EN 60079-11:2012. This must be taken into account during installation.
2. The terminal pins of the Model 3051S SuperModule must be provided with a degree of protection of at least IP20 in accordance with IEC/EN 60529.
3. The Model 3051S enclosure may be made of aluminum alloy and given a protective polyurethane paint finish; however, care should be taken to protect it from impact or abrasion if located in a zone 0 area.

IA ATEX FISCO

Certificate: BAS01ATEX1303X

Standards: EN 60079-0:2012+A11:2013, EN 60079-11:2012

Markings:  II 1 G Ex ia IIC T4 Ga, T4(-60 °C ≤ T_a ≤ +70 °C)

	FISCO
Voltage U _i	17.5 V
Current I _i	380 mA
Power P _i	5.32 W
Capacitance C _i	0
Inductance L _i	0

Special conditions for safe use (X):

1. The Model 3051S Transmitters fitted with transient protection are not capable of withstanding the 500 V test as defined in Clause 6.3.13 of EN 60079-11:2012. This must be taken into account during installation.
2. The terminal pins of the Model 3051S SuperModule must be provided with a degree of protection of at least IP20 in accordance with IEC/EN 60529.
3. The Model 3051S enclosure may be made of aluminum alloy and given a protective polyurethane paint finish; however, care should be taken to protect it from impact or abrasion if located in a zone 0 area.

International

E7 IECEx Flameproof and Dust

Certificate: IECEx KEM 08.0010X (Flameproof)

Standards: IEC 60079-0:2011, IEC 60079-1:2014, IEC 60079-26:2014

Markings: Ex d IIC T6... T4 Ga/Gb, T6(-60 °C ≤ T_a ≤ +70 °C), T5/T4(-60 °C ≤ T_a ≤ +80 °C)

Temperature class	Process temperature
T6	-60 °C to +70 °C
T5	-60 °C to +80 °C
T4	-60 °C to +120 °C

Special conditions for safe use (X):

1. This device contains a thin wall diaphragm less than 1 mm thickness that forms a boundary between EPL Ga (process connection) and EPL Gb (all other parts of the equipment). The model code and datasheet are to be consulted for details of the diaphragm material. Installation, maintenance and use shall take into account the environmental conditions to which the diaphragm will be subjected. The manufacturer's instructions for installation and maintenance shall be followed in detail to assure safety during its expected lifetime.
2. Flameproof joints are not intended for repair.
3. Non-standard paint options may cause risk from electrostatic discharge. Avoid installations that could cause electrostatic build-up on painted surfaces, and only clean the painted surfaces with a damp cloth. If paint is ordered through a special option code, contact the manufacturer for more information.
4. Appropriate cable, glands and plugs need to be suitable for a temperature of 5°C greater than maximum specified temperature for location where installed.

I7 IECEx Intrinsic Safety

Certificate: IECEx BAS 04.0017X

Standards: IEC 60079-0: 2011, IEC 60079-11:2011

Markings: Ex ia IIC T4 Ga, T4(-60 °C ≤ T_a ≤ +70 °C)

	Ui	Ii	Pi	Ci	Li
SuperModule	30 V	300 mA	1.0 W	30 nF	0
3051S...A; 3051SF...A; 3051SAL...C	30 V	300 mA	1.0 W	12 nF	0
3051S...F; 3051SF...F	30 V	300 mA	1.3 W	0	0
3051S ...A...M7, M8, or M9; 3051SF ...A...M7, M8, or M9; 3051SAL...C... M7, M8, or M9	30 V	300 mA	1.0 W	12 nF	60µH
3051SAL or 3051SAM	30 V	300 mA	1.0 W	12 nF	33µH
3051SAL...M7, M8, or M9 3051SAM...M7, M8, or M9	30 V	300 mA	1.0 W	12 nF	93µH
RTD Option for 3051SF	5 V	500 mA	0.63 W	N/A	N/A

Special conditions for safe use (X):

1. The Model 3051S Transmitters fitted with transient protection are not capable of withstanding the 500 V test as defined in Clause 6.3.13 of IEC 60079-11:2011. This must be taken into account during installation.
2. The terminal pins of the Model 3051S SuperModule must be provided with a degree of protection of at least IP20 in accordance with IEC/EN 60529.
3. The Model 3051S enclosure may be made of aluminum alloy and given a protective polyurethane paint finish, however, care should be taken to protect it from impact or abrasion if located in a zone 0 area.

IG IECEX FISCO

Certificate: IECEx BAS 04.0017X

Standards: IEC 60079-0: 2011, IEC 60079-11:2011

Markings: Ex ia IIC T4 Ga, T4(-60 °C ≤ Ta ≤ +70 °C)

	FISCO
Voltage U _i	17.5 V
Current I _i	380 mA
Power P _i	5.32 W
Capacitance C _i	0
Inductance L _i	0

Special conditions for safe use (X):

1. The Model 3051S Transmitters fitted with transient protection are not capable of withstanding the 500 V test as defined in Clause 6.3.13 of IEC 60079-11:2011. This must be taken into account during installation.
2. The terminal pins of the Model 3051S SuperModule must be provided with a degree of protection of at least IP20 in accordance with IEC/EN 60529.
3. The Model 3051S enclosure may be made of aluminum alloy and given a protective polyurethane paint finish; however, care should be taken to protect it from impact or abrasion if located in a zone 0 area.

Brazil

I2/IB INMETRO Intrinsic Safety/FISCO

Certificate: UL-BR 15.0392X

Standards: ABNT NBR IEC 60079-0:2013, ABNT NBR IEC 60079-11:2013

Markings: Ex ia IIC T4 Ga (-60°C ≤ Ta ≤ +70°C), IP66

	U _i	I _i	P _i	C _i	L _i
SuperModule	30 V	300 mA	1.0 W	30 nF	0
3051S...A; 3051SF...A; 3051SAL...C	30 V	300 mA	1.0 W	12 nF	0
3051S...F; 3051SF...F	30 V	300 mA	1.3 W	0	0
3051S...F...IB; 3051SF...F...IB	17.5 V	380 mA	5.32 W	0	0
3051S ...A...M7, M8, or M9; 3051SF ...A...M7, M8, or M9; 3051SAL...C... M7, M8, or M9	30 V	300 mA	1.0 W	12 nF	60µH
3051SAL or 3051SAM	30 V	300 mA	1.0 W	12 nF	33µH
3051SAL...M7, M8, or M9 3051SAM...M7, M8, or M9	30 V	300 mA	1.0 W	12 nF	93µH
RTD Option for 3051SF	5 V	500 mA	0.63 W	N/A	N/A

Special conditions for safe use (X):

1. The surface resistivity of the antenna is greater than 1 GΩ. To avoid electrostatic charge build-up, it must not be rubbed or cleaned with solvents or a dry cloth.
2. The Model 701PBKFF Power Module may be replaced in a hazardous area. The Power Module has a surface resistivity greater than 1 GΩ and must be properly installed in the EAC device enclosure. Care must be taken during transportation to and from the point of installation to prevent electrostatic charge build-up.
3. The 3051S enclosure may be made of aluminum alloy and given a protective polyurethane paint finish; however, care should be taken to protect it from impact or abrasion if located in areas that requires EPL Ga.

EAC - Belarus, Kazakhstan, Russia

IM Technical Regulation Customs Union (EAC) Intrinsic Safety

Certificate: RU C-US.AA87.B. 00378

Markings: 0Ex ia IIC T4 Ga X

3051S and 3051SMV wireless certifications

Rev 2.4

European Directive Information

A copy of the EC Declaration of Conformity can be found at the end of the Quick Start Guide. The most recent revision of the EC Declaration of Conformity can be found at Emerson.com/Rosemount.

Telecommunication compliance

All wireless devices require certification to ensure they adhere to regulations regarding the use of the RF spectrum. Nearly every country requires this type of product certification. Emerson working with governmental agencies around the world to supply fully compliant products and remove the risk of violating country directives or laws governing wireless device usage.

FCC and IC

This device complies with Part 15 of the FCC Rules. Operation is subject to the following conditions: This device may not cause harmful interference. This device must accept any interference received, including interference that may cause undesired operation. This device must be installed to ensure a minimum antenna separation distance of 20 cm from all persons.

Ordinary Location Certification

As standard, the transmitter has been examined and tested to determine that the design meets basic electrical, mechanical, and fire protection requirements by a nationally recognized test laboratory (NRTL) as accredited by the Federal Occupational Safety and Health Administration (OSHA).

Installing equipment in North America

The US National Electrical Code (NEC) and the Canadian Electrical Code (CEC) permit the use of Division marked equipment in Zones and Zone marked equipment in Divisions. The markings must be suitable for the area classification, gas, and temperature class. This information is clearly defined in the respective codes.

USA

I5 Intrinsically Safe (IS), Nonincendive (NI), and Dust-Ignitionproof (DIP)

Certificate: FM18US0009X

Standards: FM Class 3600 – 2011, FM Class 3610 – 2010, FM Class 3611 – 2004, FM Class 3810 – 2005, NEMA 250 – 2003

Markings: IS CL I, DIV 1, GP A, B, C, D; CL II, DIV 1, GP E, F, G; CL III T4; CL 1, Zone 0 AEx ia IIC T4; NI CL 1, DIV 2, GP A, B, C, D T4; DIP CL II, DIV 1, GP E, F, G; CL III, T5; T4(-50°C ≤ Ta ≤ +70°C)/T5(-50°C ≤ Ta ≤ +85°C); when connected per Rosemount drawing 03151-1000; Type 4X

Special conditions for safe use (X):

1. The Model 3051S and SMV Wireless Transmitters shall only be used with the 701PBKKF Rosemount Smartpower Battery Pack (P/N 00753-9220-0001), Computational Systems Inc Battery Pack (P/N MHM-89004) or alternatively the Perpetuum Intelligent Power Module Vibration Harvester (P/N IPM71008).
2. The transmitter may contain more than 10% aluminum and is considered a potential risk of ignition by impact or friction. Care must be taken into account during installation and use to prevent impact and friction.
3. The surface resistivity of the antenna is greater than 1GΩ. To avoid electrostatic charge build-up, it must not be rubbed or cleaned with solvents or a dry cloth.

Canada

I6 Canada Intrinsically Safe

Certificate: CSA 1143113

Standards: CAN/CSA C22.2 No. 0-10, CSA Std C22.2 No. 30-M1986, CAN/CSA C22.2 No. 94-M91, CSA Std C22.2 No. 142-M1987, CSA Std C22.2 No. 157-92, ANSI/ISA 12.27.01-2003, CSA Std C22.2 No. 60529:05

Markings: Intrinsically safe Class I, Division 1; suitable for Class 1, Zone 0, IIC, T3C; when connected per Rosemount drawing 03151-1010; Type 4x

Europe

I1 ATEX Intrinsic Safety

Certificate: Baseefa 13ATEX0127X

Standards: EN 60079-0: 2012, EN 60079-11: 2012

Markings:  II 1 G Ex ia IIC T4 Ga, T4(-60 °C ≤ Ta ≤ +70 °C)

Special conditions for safe use (X):

1. The Model 3051S Wireless and Model 3051SMV Wireless enclosure may be made of aluminum alloy and given a protective polyurethane paint finish; however, care should be taken to protect it from impact or abrasion if located in a zone 0 area.
2. The surface resistivity of the antenna is greater than 1GΩ. To avoid electrostatic charge build-up, it must not be rubbed or cleaned with solvents or dry cloth.

International

I7 IECEx Intrinsic Safety

Certificate: IECEx BAS 13.0068X

Standards: IEC 60079-0: 2011, IEC 60079-11:2011

Markings: Ex ia IIC T4 Ga, T4(-60 °C ≤ T_a ≤ +70 °C)

Special conditions for safe use (X):

1. The Model 3051S Wireless and Model 3051SMV Wireless enclosure may be made of aluminum alloy and given a protective polyurethane paint finish; however, care should be taken to protect it from impact or abrasion if located in a zone 0 area.
2. The surface resistivity of the antenna is greater than 1GΩ. To avoid electrostatic charge build-up, it must not be rubbed or cleaned with solvents or dry cloth.

Brazil

I2 INMETRO Intrinsic Safety

Certificate: UL-BR 14.0760X

Standards: ABNT NBR IEC60079-0:2008 + Errata 1:2011,
ABNT NBR IEC60079-11:2009

Markings: Ex ia IIC T4 Ga, T4(-60 °C ≤ T_a ≤ +70 °C)

Special conditions for safe use (X):

1. See certificate.

EAC - Belarus, Kazakhstan, Russia

IM EAC Intrinsic Safety

Certificate: TC RU C-US.AA87.B.00378

Markings: 0Ex ia IIC T4 Ga X (-60°C ≤ T_a ≤ +70°C)

Special Conditions for Safe Use (X):

1. See certificate.

Dimensional drawings

Figure 1. Coplanar Pressure Transmitter

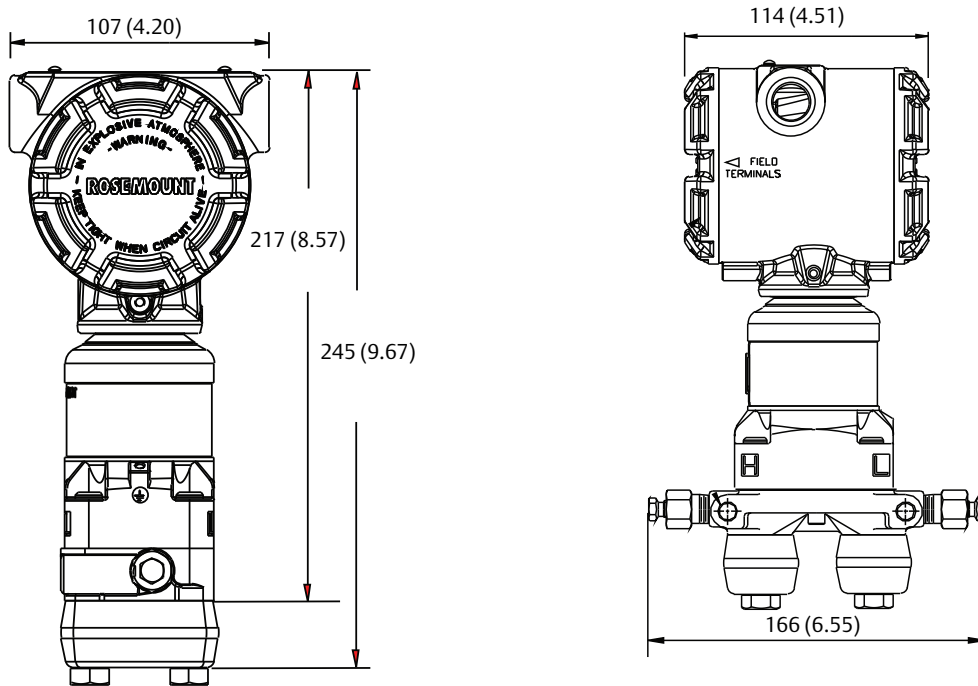
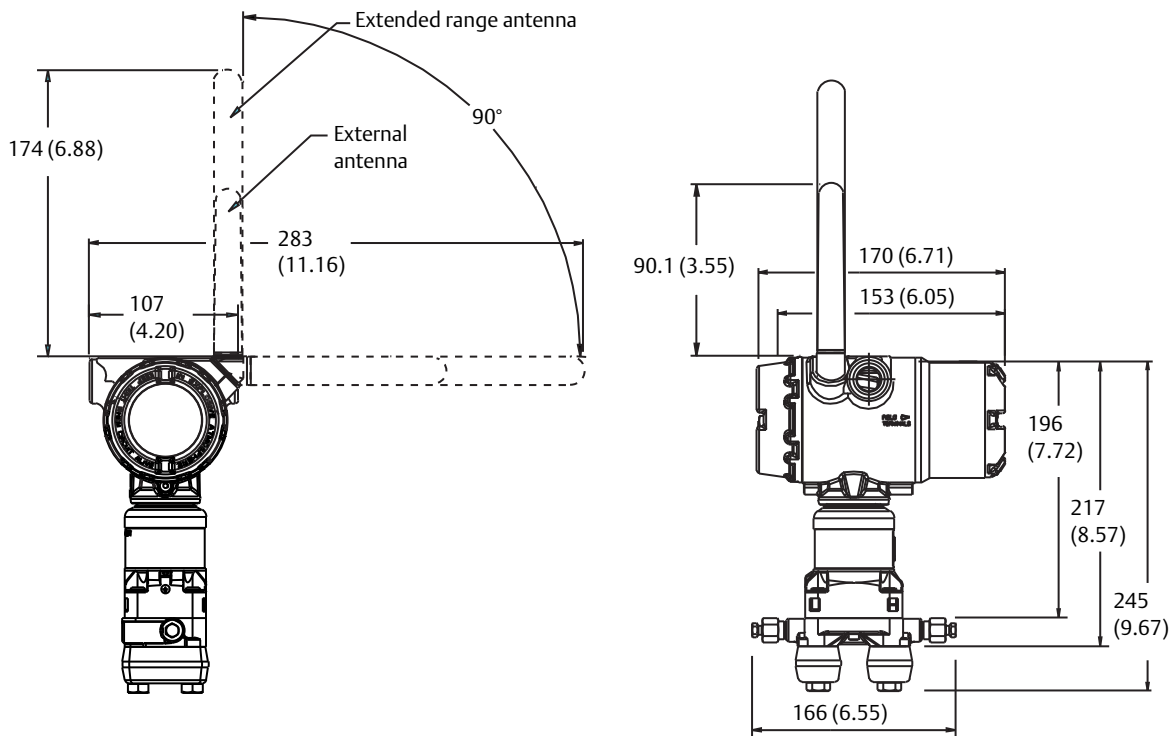

Figure 2. Wireless Version



Dimensions are in millimeters (inches).

Figure 3. Pipe Installation

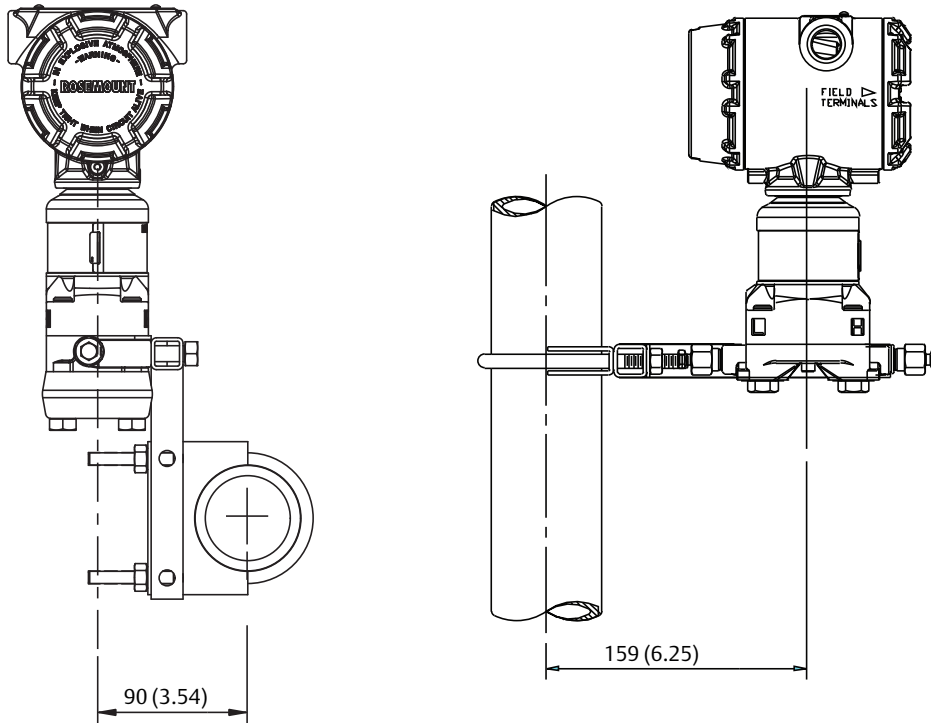
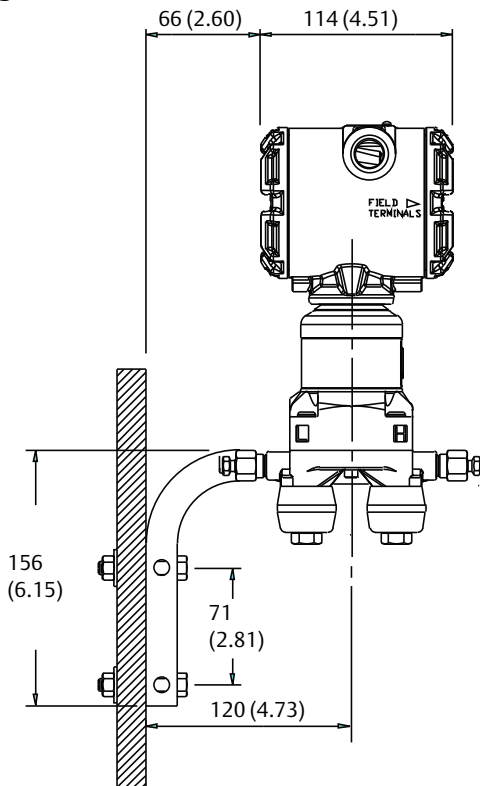
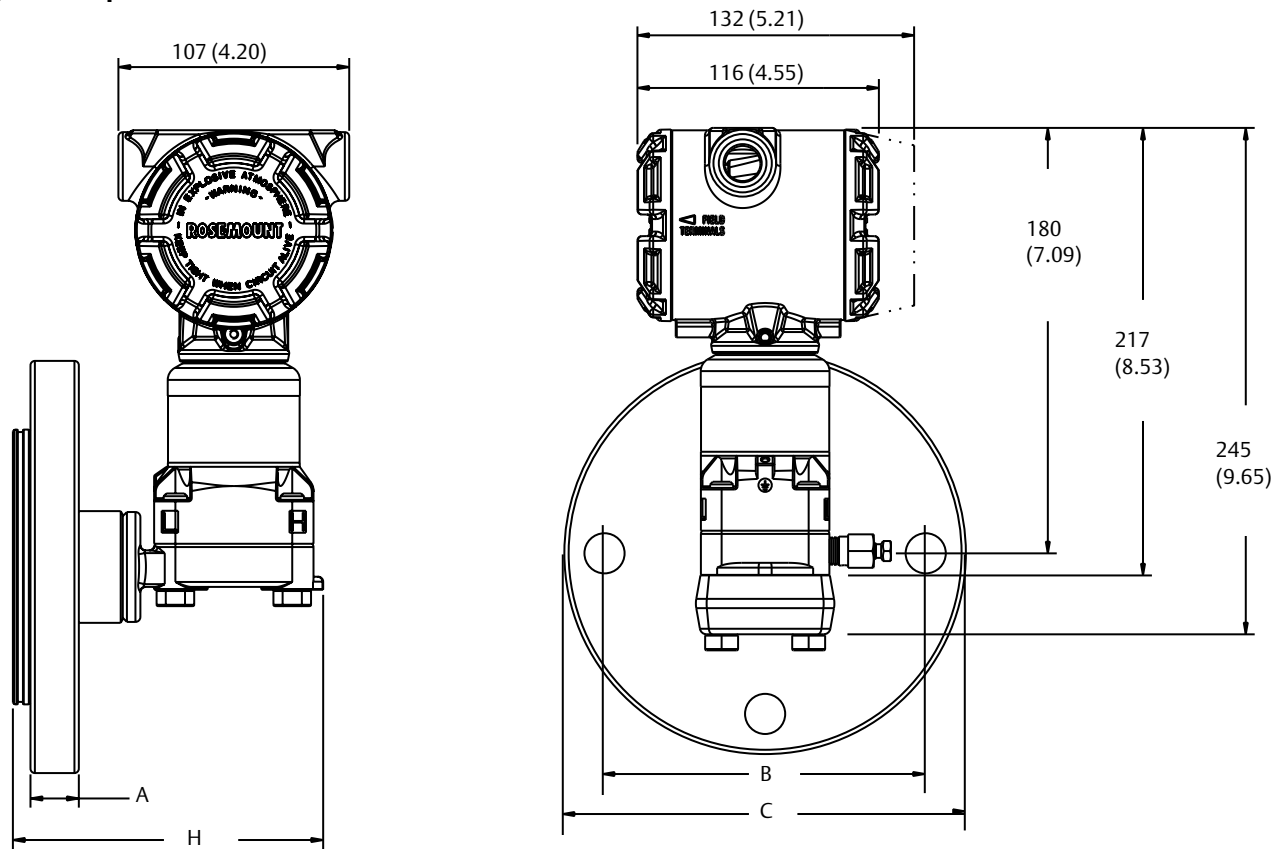

Figure 4. Panel Installation



Dimensions are in millimeters (inches).

Figure 5. Liquid Level Pressure Transmitter



Dimensions are in millimeters (inches).

Class	Pipe size	Flange thickness A	Bolt circle diameter B	Outside diameter C	No. of bolts	Bolt hole diameter	H
ASME B16.5 (ANSI) 150	51 mm (2 in.)	18 mm (0.7 in.)	121 mm (4.75 in.)	152 mm (6.0 in.)	4	19 mm (0.75 in.)	143 mm (5.6 in.)
	76 mm (3 in.)	22 mm (0.85 in.)	152 mm (6 in.)	191 mm (7.5 in.)	4	19 mm (0.75 in.)	143 mm (5.6 in.)
	102 mm (4 in.)	22 mm (0.85 in.)	191 mm (7.5 in.)	229 mm (9 in.)	8	19 mm (0.75 in.)	143 mm (5.6 in.)
ASME B16.5 (ANSI) 300	51 mm (2 in.)	21 mm (0.8 in.)	127 mm (5 in.)	165 mm (6.5 in.)	8	19 mm (0.75 in.)	143 mm (5.6 in.)
	76 mm (3 in.)	27 mm (1.05 in.)	168 mm (6.6 in.)	210 mm (8.25 in.)	8	22 mm (0.85 in.)	143 mm (5.6 in.)
DIN 2501 PN 10-40	DN 50	20 mm (0.8 in.)	125 mm (4.9 in.)	165 mm (6.5 in.)	4	18 mm (0.7 in.)	143 mm (5.6 in.)
DIN 2501 PN 25/40	DN 80	24 mm (0.95 in.)	160 mm (6.5 in.)	200 mm (7.85 in.)	8	18 mm (0.7 in.)	143 mm (5.6 in.)
	DN 100	24 mm (0.95 in.)	190 mm (7.5 in.)	235 mm (9.25 in.)	8	22 mm (0.85 in.)	143 mm (5.6 in.)
DIN 2501PN 10/16	DN 100	20 mm (0.8 in.)	180 mm (7.1 in.)	220 mm (8.65 in.)	8	18 mm (0.7 in.)	143 mm (5.6 in.)

Authorised Distributor:



46, Jalan SS 22/21, Damansara Jaya,
47400 Petaling Jaya,
Selangor Darul Ehsan, Malaysia.

Skype ID: *AmpmechSkype*
Email: *ampmech@ampmech.com*
Website: *www.ampmech.com*



[Linkedin.com/company/Emerson-Automation-Solutions](https://www.linkedin.com/company/Emerson-Automation-Solutions)



[Twitter.com/Rosemount_News](https://twitter.com/Rosemount_News)



[Facebook.com/Rosemount](https://www.facebook.com/Rosemount)



[Youtube.com/user/RosemountMeasurement](https://www.youtube.com/user/RosemountMeasurement)



[Google.com/+RosemountMeasurement](https://www.google.com/+RosemountMeasurement)

Emerson Terms and Conditions of Sale are available upon request.
The Emerson logo is a trademark and service mark of Emerson Electric Co.
Rosemount is a mark of one of the Emerson family of companies. All other
marks are the property of their respective owners.
© 2019 Emerson. All rights reserved.