

# Bronze & Steel Water Gage Valve Sets

**Bronze Valves in 12 Models for Pressures up to 450 PSI (30 Bar)**  
**Steel Valves in 16 Models for Pressures up to 3000 PSI (200 Bar)**



**Reliance<sup>®</sup>**  
A PRODUCT OF CLARK-RELIANCE

# (BG Series) Bronze Lever Operated Water Gage Valves For Dependable Steam Service to 450 PSI (30 Bar)

## Bronze Water Gage Valves Feature High Performance Materials For Heavy-Duty Service

The Clark-Reliance bronze water gage valves are designed and manufactured for demanding applications. Designed as high-grade valves, all models feature valve bodies and packing nuts constructed from compliant bronze material to meet the requirements of the ASME Boiler and Pressure Vessel Code. Additional design features include an 18-position gage lever (see page 5), integral seats and choice of screwed or flanged connections. Valve control is speeded by quadruple stem threads that allow full open/closed with only one-quarter turn. Refer to the Model Selection Guide for individual model information.

**Specification Data** Chains and handles that indicate open/closed positions are provided, as required by the ASME Boiler Code. Lower valves employ a 3/8" pipe tap connection for blowdown (drain). A complete valve set includes upper and lower valve and two 5-foot lengths of chain. Valve model numbers are stamped on the top of upper valve. NOTE: *Clark-Reliance does not recommend tubular glass for use above 250 WSP.*

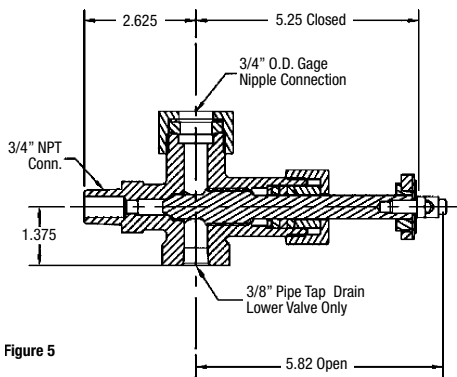

Model BG402S & BG403S with Threaded Vessel Connection

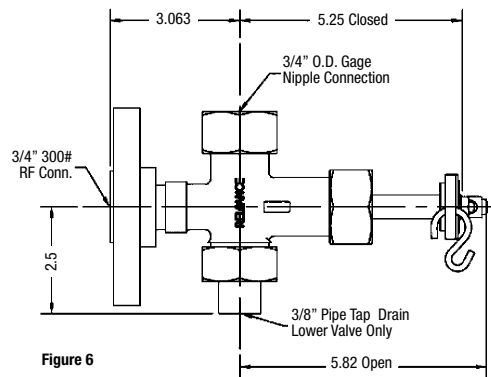

Model BG503RAS with Flanged Vessel Connection



Bronze Water Gage Valve Models BG402S & BG403S with screwed connection



Bronze Water Gage Valve Model BG404S with screwed connection



Bronze Water Gage Valve Model BG502RAS with flanged connection



Bronze Water Gage Valve Model BG503RAS with flanged connection

### Bronze Water Gage Valve Sets

Model	Design Pressure (Bar)	Vessel Connection	WT (lbs.)
BG251S	250 (17)	3/4" Male NPT w/ Ball Checks	8
BG252S	450 (31)	3/4" Male NPT w/ Ball Checks	8
BG402S	250 (17)	1/2" Male NPT	8
BG403S	250 (17)	3/4" Male NPT	8
BG404S	450 (31)	3/4" Male NPT	8
BG502RAS	250 (17)	3/4" 300# RF Flange	13
BG503RAS	450 (31)	3/4" 300# RF Flange	13
TG602RS	250 (17)	1/2" Male NPT	13
TG603RS	250 (17)	3/4" Male NPT	20
TG604RS	450 (31)	3/4" Male NPT	20
TG605RS	250 (17)	3/4" 300# RF Flange	28
TG606RS	450 (31)	3/4" 300# RF Flange	28

# SG800 Series Forged Steel Lever Operated Water Gage Valves For Dependable Steam Service to 1500 PSI (100 Bar)

## SG800 Series Lever Operated Forged Steel Water Gage Valves

For Dependable Steam Service to 1500 PSI at 600°F

### Available with 3/4" Male Pipe Connection or Standard ANSI Flange

SG800 Series valves offer choices in vessel and gage connections, ball check locations, and union availability. Refer to the Model Selection Guide for individual model features to meet your specific installation requirements.

All SG800 Series valves are of outside screw and yolk design. Design and performance features include:

- Forged steel body to ASTM SA-105 Specification
- Type 303 stainless steel stem and one-piece 420F stainless steel replaceable seat (see page 5)
- Grafoil Packing Cartridge (see page 5) is secured by identical two-bolt packing yokes
- Quadruple stem thread allows full open/closed positions with only one-quarter level turn
- Stem brushing is positioned outside body, away from high temperatures and corrosive fluids
- 1/2" Female NPT/SW connection for blowdown

SG800 Series forged steel water gage valve model SG854 with 3/4" male pipe vessel connection and nipple gage connection



SG800 Series forged steel water gage valve model SG860 with 3/4" 900 lb. RF flange vessel connection and nipple gage connection



SG800 Series  
Model SG854S (Standard)

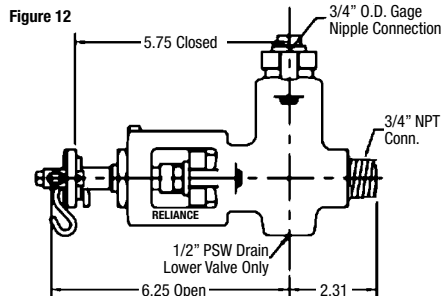

SG800 Series  
Model SG860S (Standard)

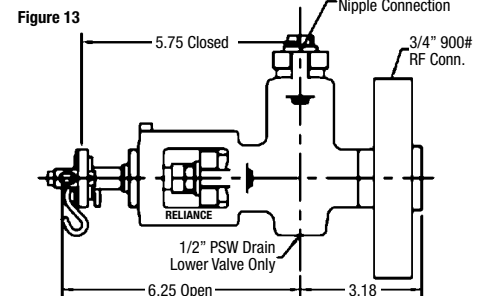

SG800 Series  
Model SG855S

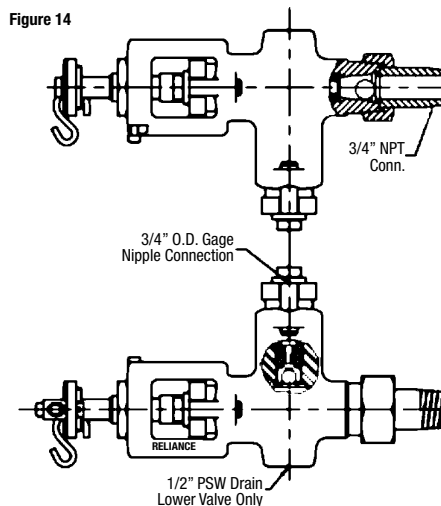

SG800 Series  
Model SG861US

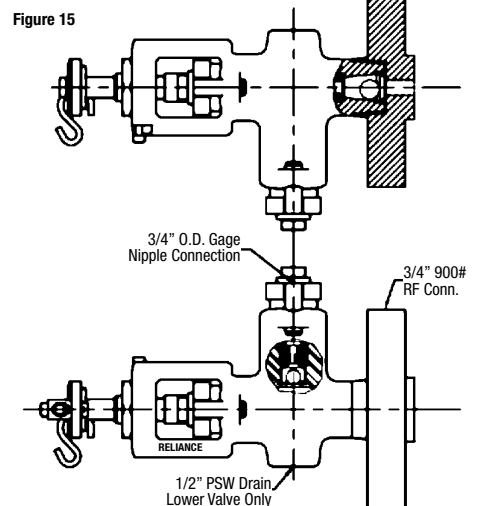

SG800 Series  
Model SG886S

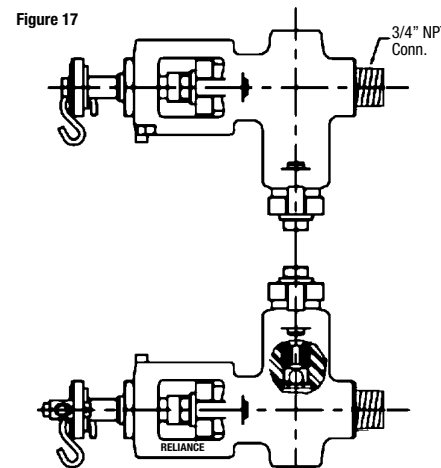

SG800 Series  
Model SG885US

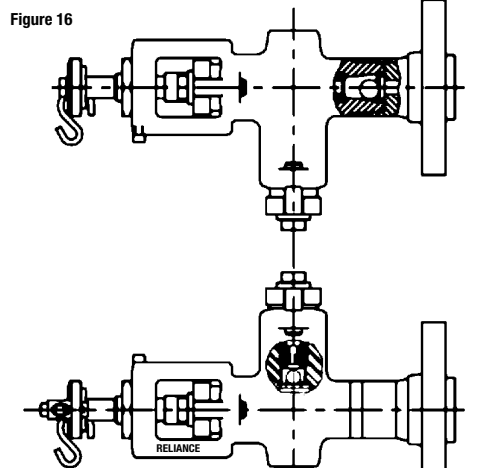

# SG600 and SG700 Series Forged Steel Chain Wheel Operated Water Gage Valves For Dependable Steam Service to 3000 PSI (200 Bar)

## SG600 Series & SG700 Series Wheel Operated Forged Steel Water Gage Valves

For Dependable Steam Service to 3000 PSI at 700°F

### Exclusively Chain Wheel Operated Models

SG600 Series & SG700 Series valves offer choices in vessel and gage connections, equalizer tube availability and maximum steam pressure services. Refer to the Model Selection Guide for individual model features to meet your specific installation requirements.

All chain wheel operated models are of outside screw and yok design. Design and performance features include:

- Forged steel body to ASTM SA-105 Specification
- Type 303 stainless steel stem
- On Series 700 models only, one-piece 420F stainless steel replaceable seat (see page 5)
- Grafoil Packing Cartridge (see page 5) is secured by identical two-bolt packing yokes
- Single-pitch stem thread allows easy valve operation by chain wheel
- Stem bushing is positioned outside body, away from high temperatures and corrosive fluids
- 1/2" Female SW connection for blowdown

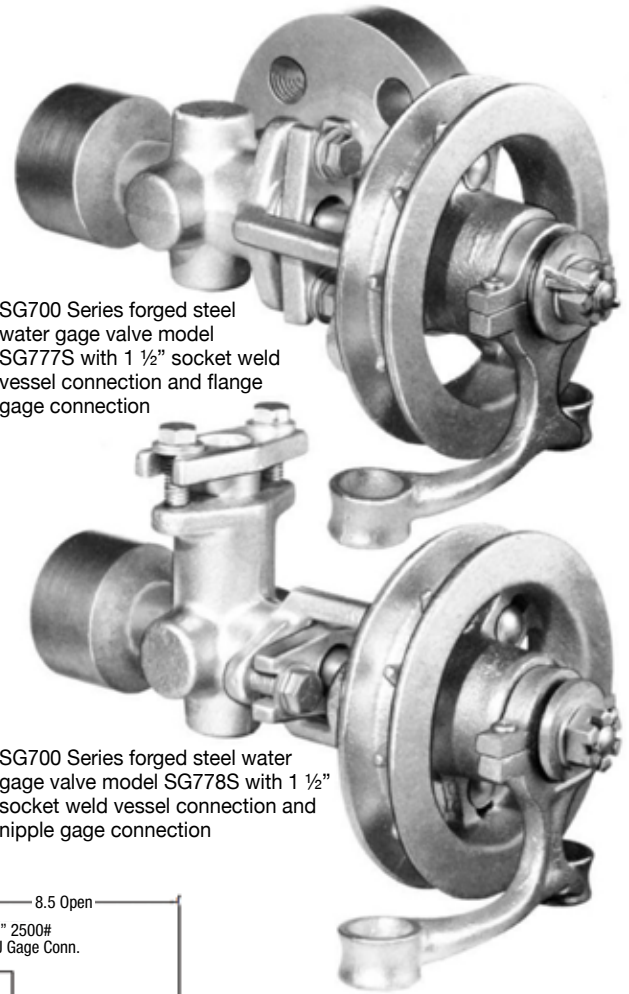

SG700 Series forged steel water gage valve model SG777S with 1 1/2" socket weld vessel connection and flange gage connection

SG700 Series forged steel water gage valve model SG778S with 1 1/2" socket weld vessel connection and nipple gage connection

SG600 Series Model SG677S Lower Valve (Top View)

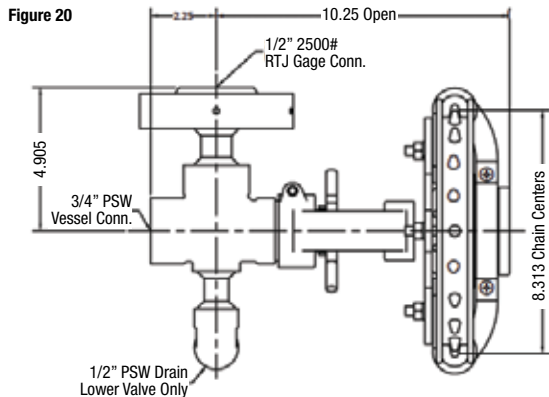

SG700 Series Model SG777S Lower Valve (Top View)

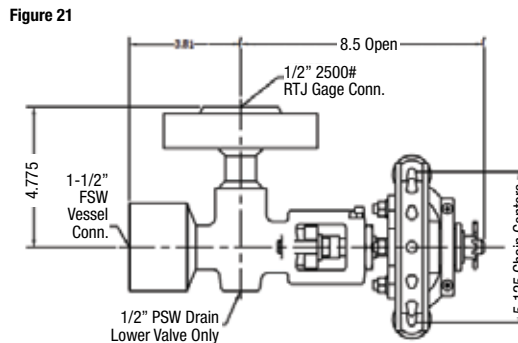

SG700 Series Model SG778S Lower Valve (Side View)

Figure 22

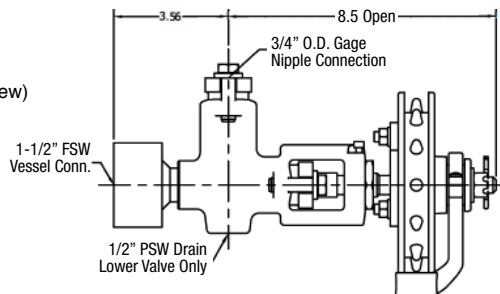

**NOTE:** Female socket weld connectors are not included when valves are to be welded to water columns. To specify for the above applications, add "C" to model numbers. Example: Model SG777S (with socket weld connectors) becomes Model SG777CS (without socket weld connectors).

**Standard Drain Connections**  
 SG800 Series – 1/2" Female NPT/Socket Weld  
 SG600 & SG700 – 1/2" Socket Weld  
 \*except model SG778S – 1/2" Female NPT/Socket Weld

# Steel Water Gage Valves

Steel Water Gage Valve Sets					
Model	Design Pressure (Bar)	Vessel Connection	Ball Checks	Gage Connection	WT (lbs.)
SG677S	3000 (206)	¾" Female SW	Optional	½" 2500# RTJ	27
SG777S	2500 (172)	1 ½" Female SW	Optional	½" 2500# RTJ	20
SG777CS	2500 (172)	¾" Male NPT	Optional	½" 2500# RTJ	18
SG777CMSW	2500 (172)	¾" Male SW	Optional	½" 2500# RTJ	18
SG778S	1500 (103)	1 ½" Female SW	Optional	¾" OD Nipple	18
SG854S	1500 (103)	¾" Male NPT	No	¾" OD Nipple	15
SG854F-300	605 (42)	¾" Male NPT	No	¾" 300# RF	20
SG854F-600	1135 (78)	¾" Male NPT	No	¾" 600# RF	22
SG854F-900	1500 (103)	¾" Male NPT	No	¾" 900# RF	24
SG855S	1500 (103)	¾" Male NPT	Yes	¾" OD Nipple	16
SG860S	1500 (103)	¾" 900# RF Flange	No	¾" OD Nipple	24
SG861S	1500 (103)	¾" 900# RF Flange	Lower (only)	¾" OD Nipple	24
SG861US	1500 (103)	¾" 900# RF Flange	Yes	¾" OD Nipple	24
SG885S	1135 (78)	¾" 600# RF Flange	Lower (only)	¾" OD Nipple	24
SG885US	1135 (78)	¾" 600# RF Flange	Yes	¾" OD Nipple	24
SG886S	1500 (103)	¾" Male NPT	Lower (only)	¾" OD Nipple	15

## 18-Position Gage Lever

Positive, non-slip locking in 18 positions is assured with the patented Clark-Reliance gage lever. The lever is standard on all bronze and SG800 Series forged steel water gage valves. The gage lever is readily adjusted to the desired angle regardless of the valve stem orientation when the valve is closed.

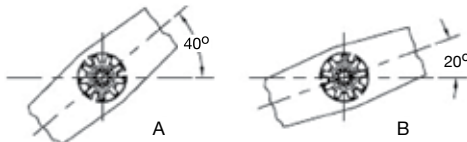

Moving the lever from position A to B achieves an intermediate angle adjustment quickly and easily.

## Grafoil Packing Cartridge



Clark-Reliance forged steel water gage valves feature advanced packing cartridges for the operating stem and nipple (end stem) gage connections which provides leak-free operation. The cartridge replaces loose, individual packing washers and is now standard on all Series 600, 700, and 800 models. The cartridge is also provided in the RK-34 Live-Loading Retrofit Kit (Figure 30).

## One-Piece Valve Seat



**Figure 25**  
REPLACEABLE SEAT  
WITH HEX HEAD

Faster renewing, improved performance and longer service life are all benefits of the one-piece valve seat standard in SG700 Series and SG800 Series valves. Machined from 420F stainless steel, the hardened valve seat offers precise fit and flow surfaces.

# Ball Check Valves

## Automatic Ball Check Valve Protect Against Blowout Damage

Where specifications require use of automatic ball check valves ahead of a water level gage, Model SG77BC Upper & Lower Check Valves can be factory installed. Note the 1.125 inch offset in elevation between inlet and outlet ports of the Lower Ball Check Valve. This applies only to the SG600 and SG700 Series valves.

These independent check valves comply with Par. A-18 of Section I of the ASME Boiler Code. The automatic valves will severely restrict the flow of steam and water to the level gage in the event of glass breakage or gasket blowout.

Caution While the advantage of using these check valves ahead of a level gage is evident, as presented above, the principal disadvantage is that the check valves will prevent effective blowdown of the level gage itself.

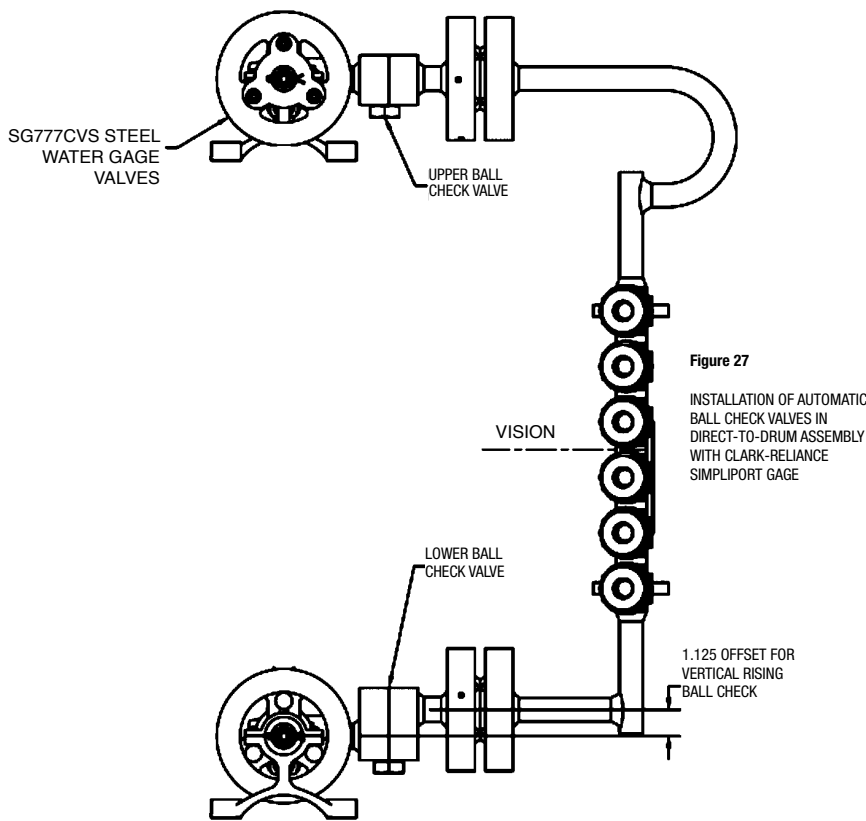
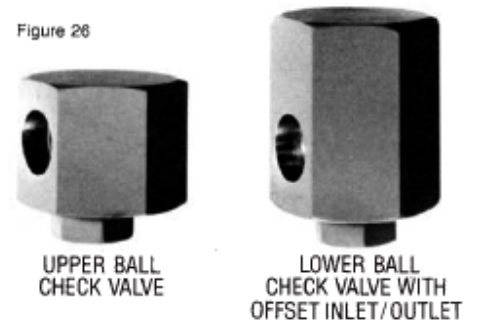

Figure 27  
INSTALLATION OF AUTOMATIC BALL CHECK VALVES IN DIRECT-TO-DRUM ASSEMBLY WITH CLARK-RELIANCE SIMPLIPORT GAGE

Figure 28



When the level gage drain valve is opened, pressure inside the level gage drops, and the check valve balls are driven up into closed positions by the system pressure. Order Clark-Reliance Automatic Ball Check Valves by using the following numbers:

- Upper Ball Check Valve: SG77BCU
- Lower Ball Check Valve: SG77BCL
- Ball Check Valve Set: SG77BC

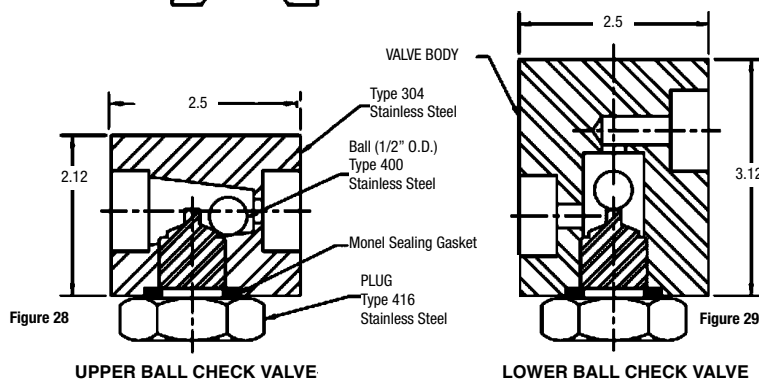

Figure 28

Figure 29

UPPER BALL CHECK VALVE

LOWER BALL CHECK VALVE

# Live Loading Option

## LIVE-LOADING RETROFIT KIT FOR SG SERIES FORGED STEEL WATER GAGE VALVES

Fits all SG700 Series and SG800 Series Models

Available As Specified Option On New Valves\*

The Clark-Reliance RK-34 Live-Loading Kit is available to improve the performance and service life of SG700 and SG800 Series valves already installed. Live-loading produces a more leak-free valve, resisting damage from vibration, pressure changes, time in service and other wear factors.

The kit includes all required parts and comes complete with step-by-step instructions for easy and rapid conversion.

### RK-34 Retrofit Parts Combine with Existing Parts to Achieve Live-Loading Performance. Retrofit Kit

Includes:

- 2 Cap Screws
- 4 Flat Washers
- 1 Graphite Packing Cartridge
- 8 Spring Washers
- Instructions

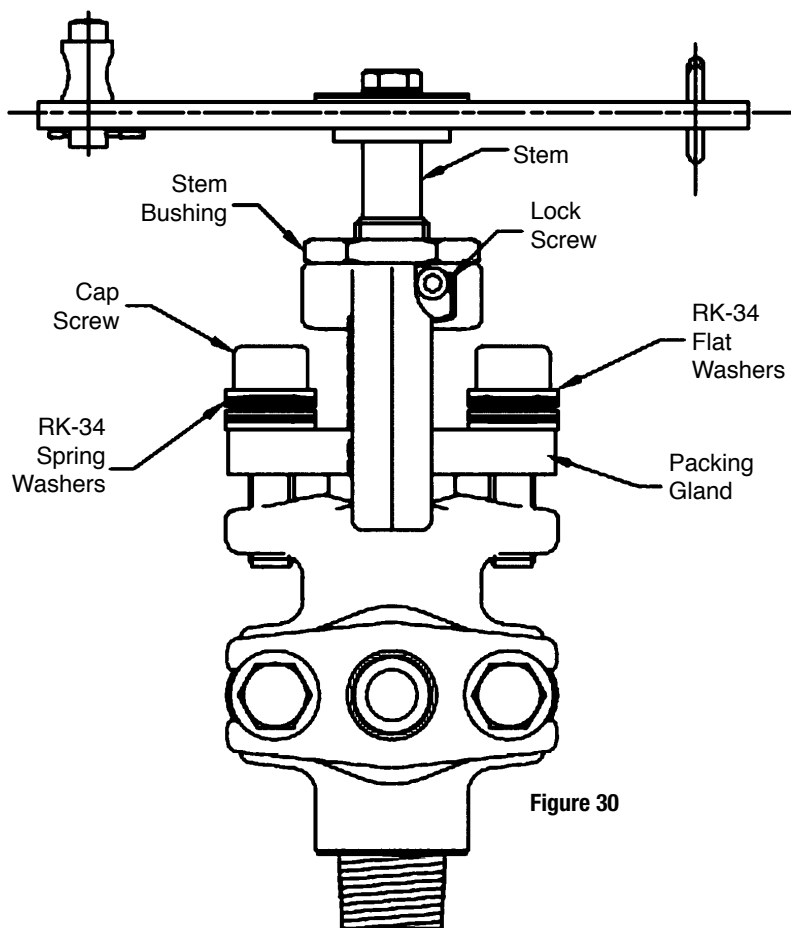

Figure 30

\*To specify Live-Loading on new valves, add "P" to the model numbers. (Example: SG854P)

# From the World's Largest Selection Of Boiler Instrumentation and Control Devices



**Eye-Hye® SmartLevel™**  
Local and Remote Indicators



**Flat Glass Gages**  
and Illuminators



**LevelMax**  
Systems



**Simpliport® 180**  
Water Gage System



**Levalarm® Gold**  
Boiler Level Switches

Maintain Optimum Performance and  
Accuracy with OEM Parts

Critical spare parts for overnight delivery,  
direct from the manufacturer.



[clark-reliance.com/parts](http://clark-reliance.com/parts)



Authorised Distributor:



46, Jalan SS 22/21, Damansara Jaya,  
47400 Petaling Jaya,  
Selangor Darul Ehsan, Malaysia.

Email: [ampmech@ampmech.com](mailto:ampmech@ampmech.com)  
Website: [www.ampmech.com](http://www.ampmech.com)

Clark-Reliance is a registered trademark of The Clark-Reliance Corporation © 2018 The Clark-Reliance® Corporation