

Jacoby-Tarbox® Eductors™ For Mixing, Blending & Suspending Solids

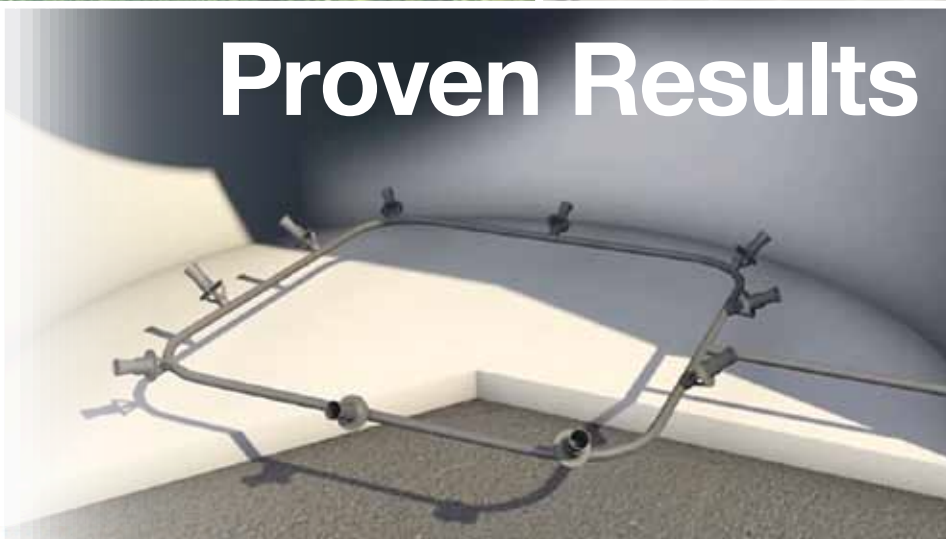

by
AccuBlend CFD
A Jacoby-Tarbox® Program™

Proven Results



JACOBY-TARBOX®
A PRODUCT OF CLARK-RELIANCE

AccuBlend CFD

A Jacoby-Tarbox® Program™

Eductors require no power, which means no moving parts. The design of the eductor creates pressure differential allowing fluid to flow naturally within the device - creating suction, mixing, and pushing the liquid throughout the tank.

Jacoby-Tarbox® TLAs™ & Jacoby-Tarbox® In-line Eductors™ are designed and built to provide optimum performance.

We can prove it !

Jacoby-Tarbox® is the only Eductor manufacturer that can design your mixing solutions based on actual computational data.

Send us your specifications:

- 1. Goal of Mixing:**
blend, suspend solids, stratified layers, heating
- 2. Tank or Reservoir dimensions**
- 3. Fluid properties**
- 4. Turnover time**

We will send you the proof !



Proven Results

“Without the AccuBlend CFD (Computation Fluid Dynamics) information to review, we would not have considered eductors for this project.”

Note – mechanical mixers were used previously

Senior Project Specialist
for an International Car Manufacturer

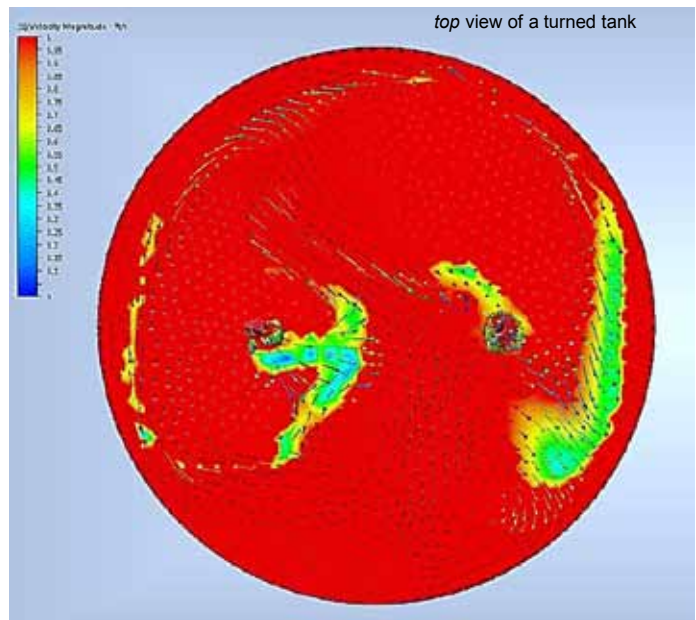

Actual screen-shot of AccuBlend CFD

Our engineers will simulate your mixing application in our **AccuBlend CFD** (Computational Fluid Dynamics) program and show you the stages of mixing, including flow and directional velocities, until fully blended.

We can provide the number of TLAs required for your mixing needs and visually show; velocity profiles, velocity of the fluid in the tank, and a digital video snapshot of your tank being mixed over time.

CFD Tank Analysis

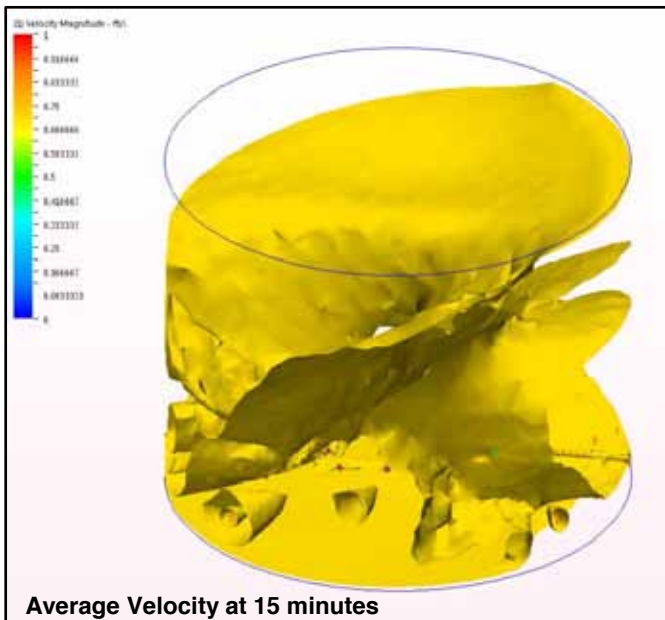
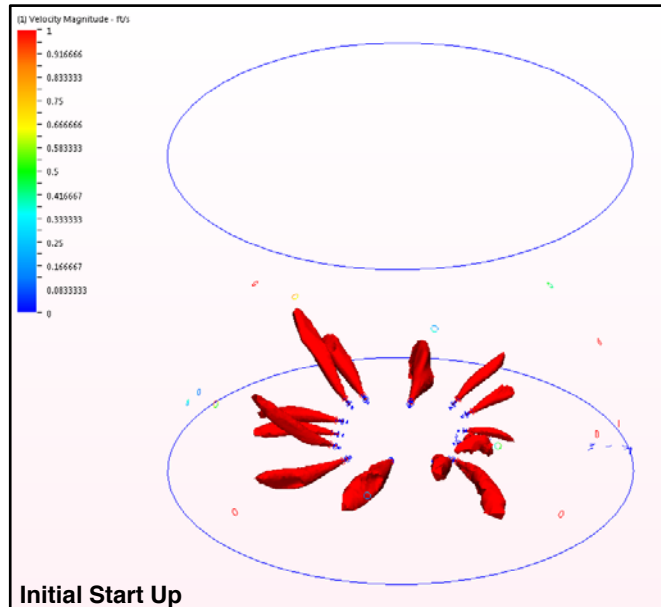
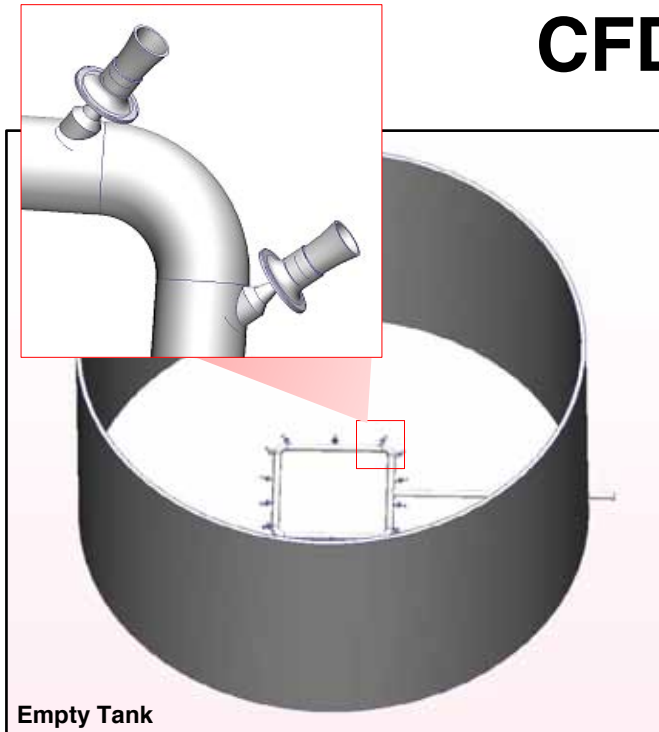

AccuBlend CFD
A Jacoby-Tarbox® Program™

See Your Solution at
www.jacoby-tarbox.com/cfd

Top view

Front view

Completely Turned at 48 minutes

Application Specifications:
Media: Wastewater
Tank Pressure: Atmospheric
Tank Dims: 32' H x 35' D
Turnover Time: 55 minutes

CFD Summary:
Pump Pressure: 20 psig
Maximum Flow Field: 38.2 feet
Turnover Time: 48 minutes
Average Velocity: 0.45ft/sec.

Solution / Specification:
TLA Size: 2"
TLA Material: 316 SS
Qty: 14

The different colors represent velocity magnitude in the tank, dark blue having no movement and red having the highest movement. In the completely turned tank, there may be two different velocities but there is overall movement in the tank. In this example, the tank is 32 feet tall and 35 feet diameter. Desired pump pressure is 20 PSIG and tank pressure is atmospheric. The required turnover time is 55 minutes.

Jacoby-Tarbox® In-Line Eductors™

In-line Eductors

are the *Next Generation* of jet pumps, ejectors, and venturi pumps, providing in-line mixing, pumping, or heating in various process lines. Eductors decrease costs as there are no moving parts and require no direct power.

... a greener, safer solution

CFD Validated Design, Full ASME Rating

- CFD used to maximize efficiency and performance
- Smooth specified finish for optimum flow paths
- Mixing tube section designed to withstand pipe stress
- Wrench flats to prevent damage during installation

Superior by Every Measure

- Backed by superior application engineering services
- Supplied to meet your delivery schedules
- Designed and built in the USA

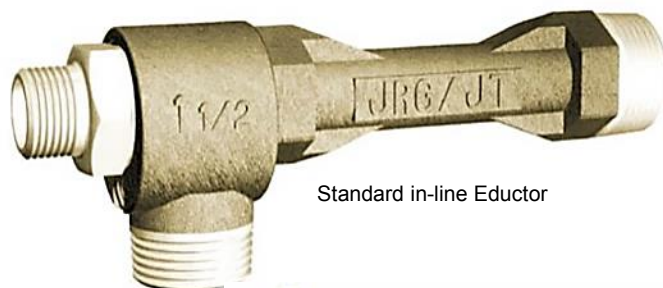

Standard in-line Eductor



Hygienic in-line Eductor

Jacoby-Tarbox®

offers a wide variety of materials depending on your specific application:

- Carbon Steel
- 316 Stainless Steel
- Bronze
- PVC / CPVC
- PVDF
- Monel®
- Alloy 20
- Hastelloy® C
- Duplex
- Stellite®

To obtain your AccuBlend CFD tank analysis, eductor inquiries, application questions or quotes, please contact us at; eductors@clark-reliance.com or call at 440-572-1500.

Please visit www.jacoby-tarbox.com for more information on Jacoby-Tarbox Products including Eductors, Sight Flow Indicators, Sight Windows and Illumination options.

Immediate availability in online store at www.clark-reliance.com/parts

JACOBY-TARBOX®
A PRODUCT OF CLARK-RELIANCE

Authorised Distributor:

AMPMECH

46, Jalan SS 22/21, Damansara Jaya,
47400 Petaling Jaya,
Selangor Darul Ehsan, Malaysia.

Email: ampmech@ampmech.com
Website: www.ampmech.com