

The Ultimate Level Switches for **Reliability & Security** for Boiler & Tank Applications



Levalarm®

High/Low Water Alarm Switches
and Fuel Cutouts

Reliance®

A PRODUCT OF CLARK-RELIANCE®

The Most Secure Boiler Level Switch



Levalarm® GOLD Switch

- For Pressures up to 1000 psi (69 Bar)
- Zero effect from heat, vibration or loss of electrical power
- Positive interlocking magnet design – proven over 30 years of use
- Drop-in design requires no adjustments to commission
- Switch is factory wired to a terminal block for easy field wiring

The Levalarm GOLD switch employs the same interlocking magnet operation used by Clark-Reliance in its Jerguson Level Switches for over 30 years.

Here's how it works:

A stainless steel float is attached to the end of a rod with a stainless steel encapsulated magnet. The magnet travels vertically in the pressure tube. The primary magnet on the float rod inside the pressure tube drives the secondary magnet, which in turn drives the tertiary magnet. The tertiary magnet is mounted to the switch arm and activates the switch. The use of repelling magnetic fields create a positive interlocking switch that is vibration resistant.

A buoyed float will cause the reaction of the magnets to hold the switch open or closed, depending on which switch terminals are used. As liquid falls in the chamber,

the float drops and directs the magnets to the opposite position which activates the switch in the opposite direction.

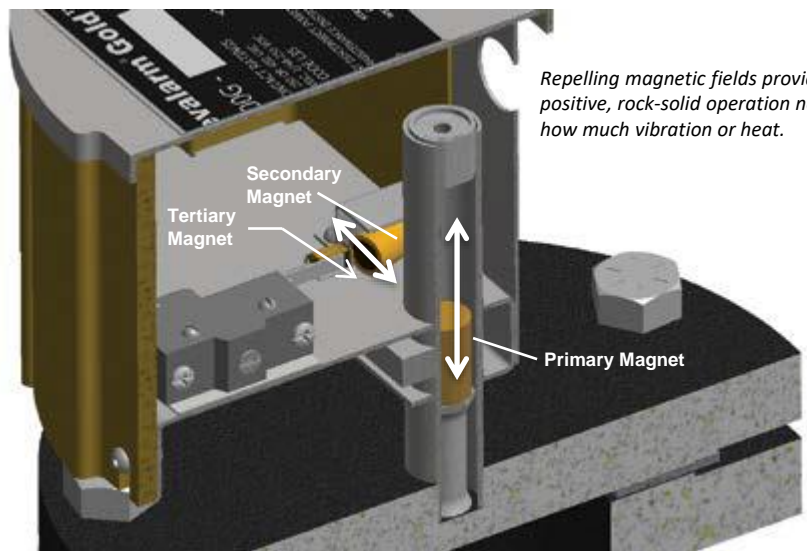

Three Models to Suit Your Boiler Applications

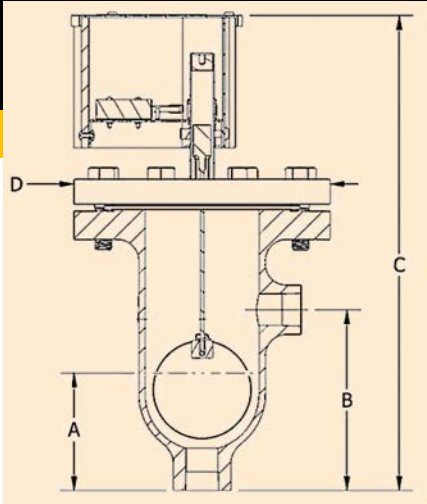

Model Dimensions – Inches (mm)

Model	A-Actuation	B-Connections	C-Height	D-Width	Weight-lb (kg)
EA100G-150	4.5 (114)	6.41 (163)	16.87 (428)	9.00 (229)	46 (20.8)
EA100G-300	4.62 (117)	6.51 (165)	17.40 (442)	10.00 (254)	65 (29.5)
EA100G-600	6.00 (152)	8.35 (212)	21.00 (533)	13.00 (330)	157 (71.2)*

* Structural support is required for this model, to be determined by installer

Agency Approvals	UL 353, FM 7710, and CSA
Connection Sizes	EA100G-150: 1" FNPT EA100G-300/EA100G-300SW: 1" FNPT/FSW EA100G-600/EA100G-600SW: 1" FNPT/FSW
Pressure Rating (MAWP = Maximum Allowable Working Pressure)	EA100G-150: 200 psi (13.8 Bar) MAWP EA100G-300/EA100G-300SW: 500 psi (34.5 Bar) MAWP EA100G-600/EA100G-600SW: 1000 psi (69 Bar) MAWP
Float Switch Rating	UL listed and CSA approved SPDT 5A, 125, 250 VAC 1/2A, 125 VDC; ¼ amp 250 VDC Switch Max Temperature: 400F
Environment	Indoor or outdoor

EA100G-600



EA100G-300



EA100G-150

Probe-Type Level Switches

For Pressures up to 1800 WSP
(124 Bar)



Series EA101

- Dual functions on boilers and tanks
- Recommended control for power plants and processing facilities

Series EA101 models provide reliable and instant response. Probes respond to the rise and fall of water at pre-determined points, to actuate a variety of controls. Each Levalarm monitors up to 3-inch level variation. Multiple units, in series, extend the monitoring range. Use almost anywhere on water applications.

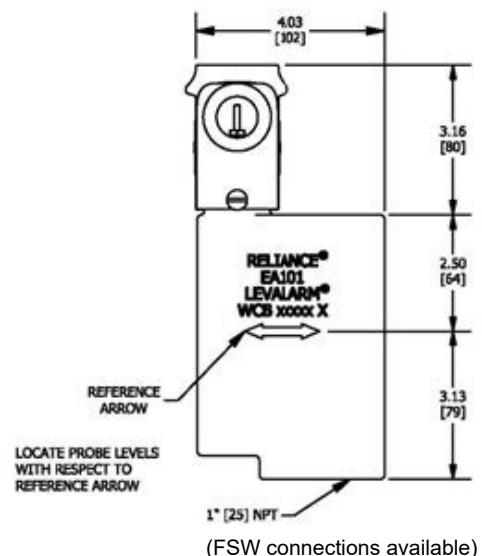
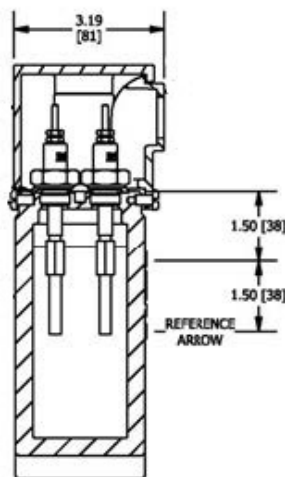
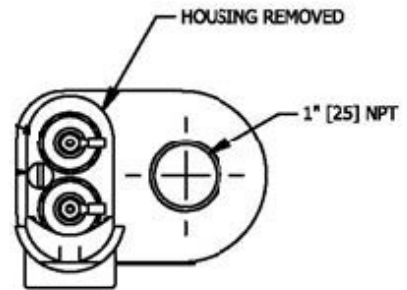

Standard Models with a Single Probe

- Model EA101D-T030 up to 350 psi (24 Bar)
- Model EA101S-V030 up to 1000 psi (69 Bar)
- Model EA101S-Z030 up to 1200 psi (82.75 Bar)
- Model EA101SW-Z030 up to 1800 psi (124 Bar)

Note: For installations in Canada, use Model EL450-1WP, EL1000-1WP, EL1800-1WP. Consult factory for details.

Retropak Assemblies

*Convert Old EA100 Float-Design Units to
Reliable Probe Operation*

- For Pressures up to 800 psi (55 Bar)
- Eliminates float mechanism
- Installs with no modification to boiler piping

For applications with EA100D, EA100S, or EA100SW legacy switches, the Retropak delivers a more reliable switch with less maintenance. The new access cover plate and probe is swapped out with the old float internals to create a dependable switch without requiring pipe modifications.



Retrofit Kit



Item # EA100DRPT
fits EA100 and EA100D



Item # EA100SRPV
fits EA100S and EA100SW

Retrofit Kit Includes:

- New flange cover with probe –
 - T probe for EA100 and EA100D models
 - V probe for EA100S models
- Probe housing kit with 1/2" conduit connection
- Replacement flange gasket
- One 30 ft. length of 18 gage Teflon® insulated wire are supplied for the installation up to 15 ft. between probe and relay

Note: Relay control sold separately

Accessories

Relay Control Modules

- Each relay control module is independently fuse protected
- Plug-in relay modules are removed by hand, no tools required
- Relays supply low voltage (12VAC) to probes
- Relays enhance sensitivity or extremely low water conductivity applications, to 1 MicroMho
- Relays improve switch contact reliability for low load applications, such as a computer interface or recorders
- Relays use integral red LED indicators to verify status
- Relays will retrofit existing system installations

Direct Mode Operation (Standard)

When water level rises to Terminal 3 Probe, water completes circuit. Circuit signals relay to change state of load contacts, activating alarm or other equipment, while illuminating the integral LED. Relay is energized until water drops below the probe to break circuit, turning off alarm and LED.

Inverse Mode Operation (Optional)

Upon powering supply terminals 1 and 2, relay energizes (LED on). When water rises to terminal 3 probe, probe signals relay to de-energize (LED off). Relay remains de-energized until water drops below the probe. Relay remains in "safe" mode in low level applications. Specify inverse mode when required.



ECID-23R Relay Module



ECID-49 Surface Mount Socket for Relay Module

Low Water Fuel Cut-Out Probe Bypass

During probe column or Levalarm blowdown, the Holding Switch (Model HS-1) provides a bypass around the fuel cut-out relay. This simple switch maintains relay circuit continuity momentarily, while being held in the bypass position during blowdown. The Holding Switch also provides an indicator light to verify that the fuel cut-out relay is functioning properly. The switch can be installed for bypass functions with probe-type Levalarm on columns, boilers or tanks. Also available without indicator light (Model HS-0).

Audible, Visual Alarms

Audible or visual alarms are available for all Levalarm applications. The vibratory horn has a decibel rating of 100 DB at 10 ft and comes in standard model (350N) or weatherproof model. Visual alarms come in Normal/Danger and High/Normal/Low models. Specify supply voltage when ordering.

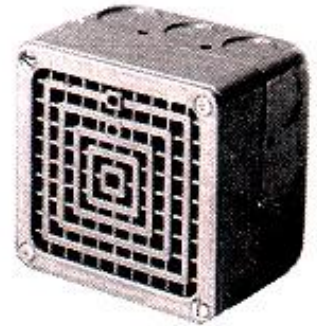

Clark-Reliance "Retropak" Models EA17 (for applications up to 4 probes) & EA18 (for applications with 5 or 6 probes) are available for converting older float-type whistle alarm water columns into modern Probe Control Stations.

Clark-Reliance Levalarm® Models: Descriptions & Functions

Model	Application	Functions	Material	Connections	Max Pressure	Switch Rating
EA100G-150	Boilers, Tanks, & Water Columns	High or Low Alarm, Fuel Cut-Out, and Pump Controls	SA-216	1" FNPT	200 psi (13.8 Bar) 500 psi (34.5 Bar) 1000 psi (69 Bar)	5A-120 & 240 V AC
EA100G-300 EA100G-600				1" FNPT 1" FSW		
EA101D				1" FNPT	350 psi (24 Bar) 1000 psi (69 Bar)	
EA101S					450 psi (31 Bar) 1000 psi (69 Bar)	
EA101SW				1" FSW	1800 psi (124 Bar)	
EA17/EA18 Retropak	Water Columns	Low Alarm Low Cut Out	SA-516 Gr. 70	Cover Plate	250 psi (17.25 Bar) Cast Iron 900 psi (62 Bar) Steel	
EA100DRPT	EA100D				350 psi (24 Bar)	
EA100SRPV	EA100S EA100SW				800 psi (55 Bar)	

These devices may be installed to meet ASME Boiler Code and ASME CSD-1 requirements.

From the World's Largest Selection of Boiler Instrumentation and Control Devices



Eye-Hye® SmartLevel™
With Local and Remote Indicators



**Flat Glass Gages
and DuraStar®
Illuminators**



**LevelMax™
Systems**



**Simpliport® 180
Water Gage System**

Maintain Optimum Performance and
Accuracy with OEM Parts

Critical spare parts for overnight delivery,
direct from the manufacturer.



clark-reliance.com/parts



Authorised Distributor:



46, Jalan SS 22/21, Damansara Jaya,
47400 Petaling Jaya,
Selangor Darul Ehsan, Malaysia.

Email: ampmech@ampmech.com
Website: www.ampmech.com