

## PRESSURE CONTROL

# Pressure reducing valve DM 652

Valve for medium to high flow rates



### Technical data

|                         |                          |
|-------------------------|--------------------------|
| Connection DN           | 15 - 50                  |
| Connection G            | 1/2 - 2                  |
| Nominal pressure PN     | 16 - 40                  |
| Inlet pressure          | up to 40 bar             |
| Outlet pressure         | 0.02 - 12 bar            |
| $K_{vs}$ value          | 5 - 22 m <sup>3</sup> /h |
| Temperature             | 190 °C                   |
| Medium                  | liquids, gases and steam |
| *RT = -10 °C TO + 50 °C |                          |

### Description

Self-acting pressure reducers are simple control valves offering accurate control while being easy to install and maintain. They control the pressure downstream of the valve without requiring pneumatic or electrical control elements.

The pressure reducing valve DM 652 is a diaphragm-controlled, spring-loaded and balanced proportional control valve for universal application. The valve is completely made of high-quality stainless steel with excellent corrosion resistance. The valve cone is fitted with a soft seal.

The spring module comprising spring cap, spring, adjusting screw, diaphragm and internal components, is connected to the valve body only by means of a clamp ring and two bolts. Changing the diaphragm or the complete spring assembly for a different control range is very easy and without special tools. The same applies to servicing and maintenance.

The outlet pressure to be controlled is balanced across the control unit by the force of the valve spring (set pressure). As the outlet pressure rises above the pressure set using the adjusting screw, the valve cone moves towards the seat and the volume of medium is reduced. As the outlet pressure drops, the valve control orifice increases; when the pipeline is depressurised, the valve is open. Rotating the adjusting screw clockwise increases the outlet pressure.

The valve requires a sense line (to be installed on-site).

These valves are no shut-off elements ensuring a tight closing of the valve. In accordance with DIN EN 60534-4 and/or ANSI FCI 70-2 they may feature a leakage rate in closed position in compliance with the leakage classes III or V, optional IV.

### Standard

- » All stainless steel construction
- » Non-rising adjusting screw
- » Quick-release body clamp ring
- » Sense line connection
- » Balanced cone for controlling the outlet pressure independently from the inlet pressure

### Options

- » Pressure gauge connection
- » Electro-pneumatic actuation
- » Internal sense line
- » Clean gas version with special connections
- » Intermediate piece for steam up to 220 °C
- » For toxic or hazardous media: sealed bonnet complete with leakage lineconnection (incl. sealed adjusting screw). Must be installed with a leakageline capable of draining leaking medium safely and without pressure
- » different materials for diaphragm and seals, suitable for your medium
- » Special connections: Aseptic, ANSI or DIN flanges, NPT, welding spigots; other connections on request
- » Special versions on request

### Product



Picture similar

### Technical specification

| $K_{vs}$ values [m <sup>3</sup> /h] |                   |     |     |    |       |       |    |
|-------------------------------------|-------------------|-----|-----|----|-------|-------|----|
| nominal diameter                    | G                 | 1/2 | 3/4 | 1  | 1 1/4 | 1 1/2 | 2  |
|                                     | DN                | 15  | 20  | 25 | 32    | 40    | 50 |
| $K_{vs}$ value                      | m <sup>3</sup> /h | 5   | 7   | 8  | 22    | 22    | 22 |

| setting range [bar] |                |                  |                |
|---------------------|----------------|------------------|----------------|
| 0.02 - 0.12*        | 0.1 - 0.5      | 0.3 - 1.1        | 0.8 - 2.5      |
| PN 16 - 40 / 1      | PN 16 - 40 / 1 | PN 16 - 40 / 2.5 | PN 16 - 40 / 6 |

| setting range [bar] |                 |                 |
|---------------------|-----------------|-----------------|
| 2 - 5               | 4 - 8           | 6 - 12          |
| PN 16 - 40 / 10     | PN 16 - 40 / 16 | PN 16 - 40 / 16 |

| Permissible Reduction Ratio (max. $p_1/p_2$ ) |                         |                           |
|---|-------------------------|---------------------------|
| setting range bar                             | nominal diameter        |                           |
|   | G 1/2 - 1<br>DN 15 - 25 | G 1 1/4 - 2<br>DN 32 - 50 |
| 0.02 - 0.12*                                  | 80                      | 50                        |
| 0.1 - 0.5                                     | 40                      | 25                        |
| 0.3 - 1.1                                     | 30                      | 18                        |
| 0.8 - 12                                      | 20                      | 12                        |

\*Recommended for gases and steam only

PRESSURE CONTROL

# Pressure reducing valve DM 652

Valve for medium to high flow rates



## Materials

| Materials*                      |  |                               |
|---------------------------------|--|-------------------------------|
| Temperature                     | 130 °C   | for steam 190 °C              |
| Body, Bonnet, Internals, Screws | stainless steel 1.4404 / 316L  | stainless steel 1.4404 / 316L |
| Spring                          | stainless steel 1.4310 / 301   | stainless steel 1.4310 / 301  |
| Valve seal                      | FEPM optional EPDM or FKM  | FEPM optional PTFE            |
| Diaphragm                       | EPDM optional FKM  | EPDM                          |
| Protection foil                 | setting range 0.8 - 12 bar with FEPM soft seal: standard<br>other pressure ranges and soft seals: option |                               |

\*All materials equal or of higher quality

## Dimensions and weights

| Dimensions [mm]     |                |                  |                |              |                  |                  |              |
|---------------------|----------------|------------------|----------------|--------------|------------------|------------------|--------------|
| Setting range [bar] | size           | nominal diameter |                |              |                  |                  |              |
|                     |                | G 1/2<br>DN 15   | G 3/4<br>DN 20 | G 1<br>DN 25 | G 1 1/4<br>DN 32 | G 1 1/2<br>DN 40 | G 2<br>DN 50 |
| all ranges          | A*             | 85               | 91             | 85           | 130              | 145              | 185          |
|                     | A <sub>1</sub> | 130              | 150            | 160          | 180              | 200              | 230          |
|                     | B              | 76               | 76             | 76           | 80               | 80               | 80           |
| 0.02 - 0.12         | C              | 300              | 300            | 300          | 300              | 300              | 300          |
|                     | D              | 360              | 360            | 360          | 360              | 360              | 360          |
| 0.1 - 0.5           | C              | 300              | 300            | 300          | 300              | 300              | 300          |
|                     | D              | 264              | 264            | 264          | 264              | 264              | 264          |
| 0.3 - 1.1           | C              | 300              | 300            | 300          | 300              | 300              | 300          |
|                     | D              | 200              | 200            | 200          | 200              | 200              | 200          |
| 0.8 - 2.5           | C              | 235              | 235            | 235          | 235              | 235              | 235          |
|                     | D              | 138              | 138            | 138          | 138              | 138              | 138          |
| 2 - 5               | C              | 235              | 235            | 235          | 235              | 235              | 235          |
|                     | D              | 138              | 138            | 138          | 138              | 138              | 138          |
| 4 - 8               | C              | 235              | 235            | 235          | 235              | 235              | 235          |
|                     | D              | 138              | 138            | 138          | 138              | 138              | 138          |
| 6 - 12              | C              | 235              | 235            | 235          | 235              | 235              | 235          |
|                     | D              | 138              | 138            | 138          | 138              | 138              | 138          |

\*overall length tolerances in acc. with DIN EN 558

| Weight [kg]         |              |      |      |       |       |      |
|---------------------|--------------|------|------|-------|-------|------|
| Setting range [bar] | Connection G |      |      |       |       |      |
|                     | 1/2          | 3/4  | 1    | 1 1/4 | 1 1/2 | 2    |
| 0.02 - 0.12         | 13.5         | 13.5 | 13.5 | 14.4  | 14.4  | 14.4 |
| 0.1 - 0.5           | 7.1          | 7.1  | 7.1  | 8     | 8     | 8    |
| 0.3 - 1.1           | 6.1          | 6.1  | 6.1  | 7     | 7     | 7    |
| 0.8 - 12            | 3.1          | 3.1  | 3.1  | 4     | 4     | 4    |

| Weight [kg]         |                     |      |      |      |      |      |
|---------------------|---------------------|------|------|------|------|------|
| Setting range [bar] | nominal diameter DN |      |      |      |      |      |
|                     | 15                  | 20   | 25   | 32   | 40   | 50   |
| 0.02 - 0.12         | 15.3                | 15.3 | 15.3 | 18.4 | 18.4 | 18.4 |
| 0.1 - 0.5           | 8.9                 | 8.9  | 8.9  | 12   | 12   | 12   |
| 0.3 - 1.1           | 7.9                 | 7.9  | 7.9  | 11   | 11   | 11   |
| 0.8 - 12            | 4.9                 | 4.9  | 4.9  | 8    | 8    | 8    |

| Customs tariff number |
|-----------------------|
| 84811019              |

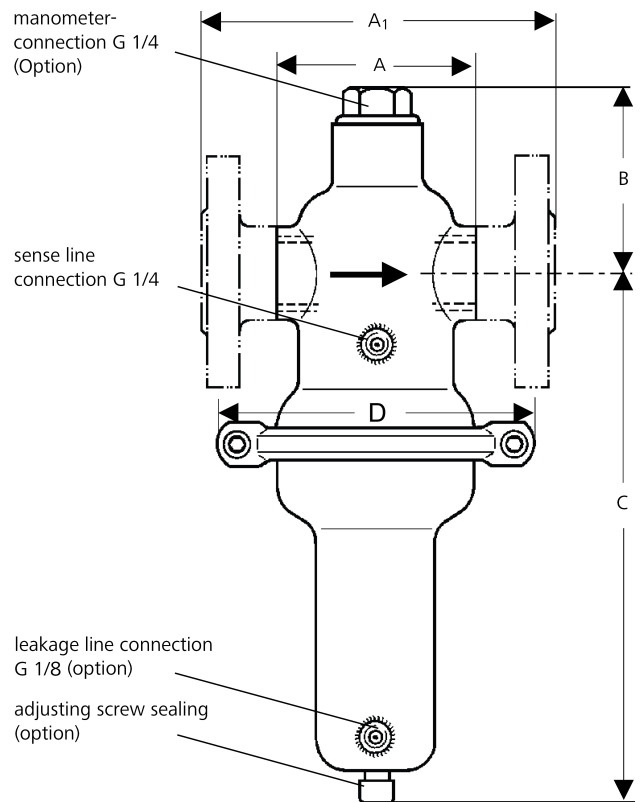

Mankenberg GmbH | Spenglerstrasse 99 | D-23556 Luebeck | Germany

Please send us your enquiry and allow us to advise you. Special designs on request.  
The pressure has always been indicated as overpressure. Mankenberg reserves the right to alter technical specifications without notice.

# Pressure reducing valve DM 652

Valve for medium to high flow rates

## Recommended installation

- 1 Strainer
- 2 Shut-off valves
- 3 Pressure reducing valve
- 4 Safety valve
- 5 Pressure gauge
- 6 Sense line
- 7 Leakage line

Sense line connection 10 - 20 x DN behind the valve

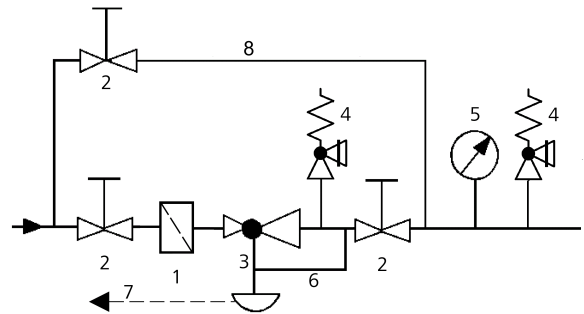

**Authorised Distributor:**



46, Jalan SS 22/21, Damansara Jaya,  
47400 Petaling Jaya,  
Selangor Darul Ehsan, Malaysia.

Email: [ampmech@ampmech.com](mailto:ampmech@ampmech.com)  
Website: [www.ampmech.com](http://www.ampmech.com)

Please send us your enquiry and allow us to advise you. Special designs on request.  
The pressure has always been indicated as overpressure. Mankenberg reserves the right to alter technical specifications without notice.