

Reliance[®]

Prismatic Water Gages

Cast and Steel Body Type



Reliance®

PRECISE, EASY-TO-READ LEVEL GAGES MEET A WIDE VARIETY OF INSTALLATION REQUIREMENTS

Reliance Prismatic (reflex) Gages provide a well-defined, distinct image of water level, eliminating reading errors or distortions possible with less effective gage types. Highly versatile, Prismatic Gages are easily installed in vertical or Tiltview™ Assemblies. In addition, Reliance Prismatic Gages offer the flexibility of combining multiple gage sections to achieve coverage of extended viewing areas.

Available in two designs, “C” Types are specified for boiler design pressures to 250 PSI and “S” Types for pressures to 350 PSI.

Typical Prismatic Gage applications include installation on boiler drums, feedwater heaters, deaerators, and other tanks.

Quality Materials Reliance Prismatic Gages feature quality materials and reliable design. The gage glass is of the highest quality borosilicate glass, tempered for improved toughness.

The unique Reliance clamping design produces a uniform, firm, compressive load on the glass –adding to gage reliability and prolonged service life.

THE PRISMATIC PRINCIPLE

Prismatic glass is flat on the outside. The inside, in contact with either water or steam, is shaped with multiple 90° angle prisms.

Rays of light normal to glass strike the prisms at a 45° angle.

The critical angle of a ray passing from glass to steam is 42°. Therefore, the 45° ray is totally reflected and causes the steam space to appear white (Figure 2).

The critical angle of a ray passing from glass to water is 62°. Therefore, with the 45° angle being less, the ray penetrates the water and reveals the gage housing in black (Figure 3).

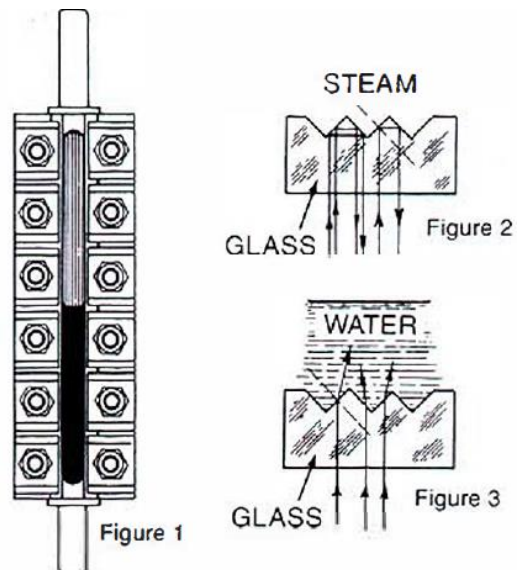

STEAM APPEARS WHITE
WATER APPEARS BLACK

Reliance®

MULTIPLE SECTIONS ALLOW LONGER LEVEL VIEWING AREAS

Large storage tanks, heater tanks and similar applications call for Prismatic Gage assemblies employing multiple gage sections. Double, triple and quadruple assemblies are available, and even longer assemblies can be provided.

In multiple assemblies, the space between gage windows is approximately 1 ½ inches. This gap is generally considered insignificant where multiple assemblies are normally installed.

Note the various dimensions and specifications for multiple gage assemblies listed in tables presented on page 5.

In gages of three or more sections, side-mounted reinforcing bars connect all gage bodies to assure proper alignment.

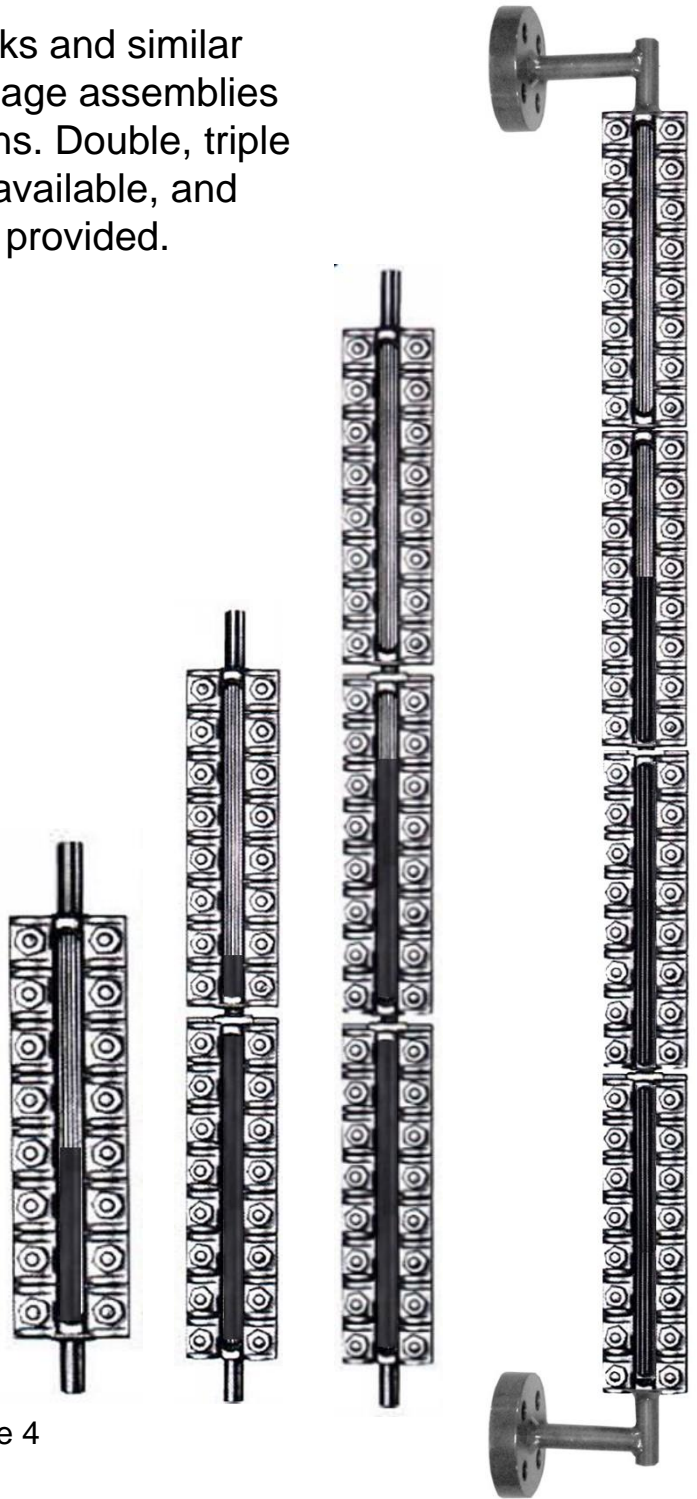
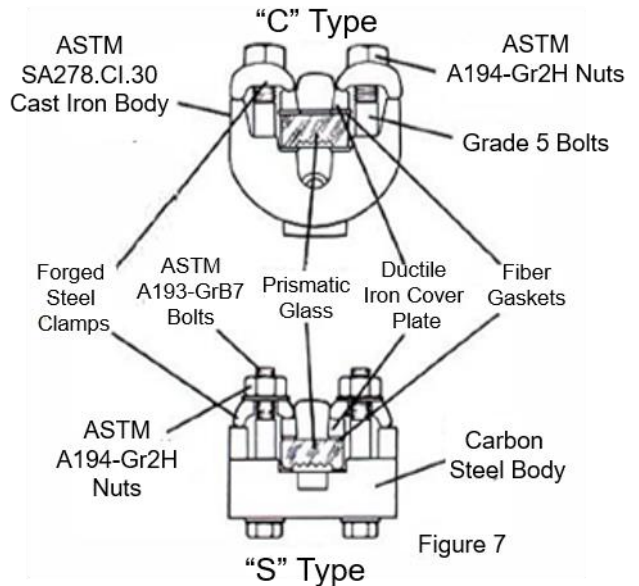
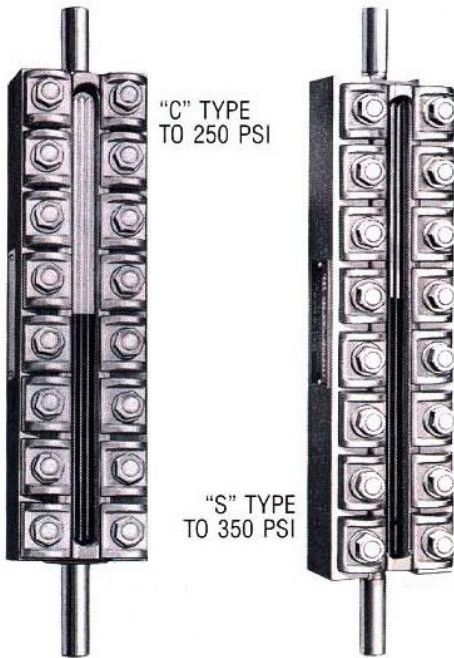

Figure 4

Reliance®

GAGE SELECTION DATA



Specific combinations of boiler water pressure and boiler water pH levels suggest the installation of mica-protected gages to resist gage glass deterioration and possible gage leakage.

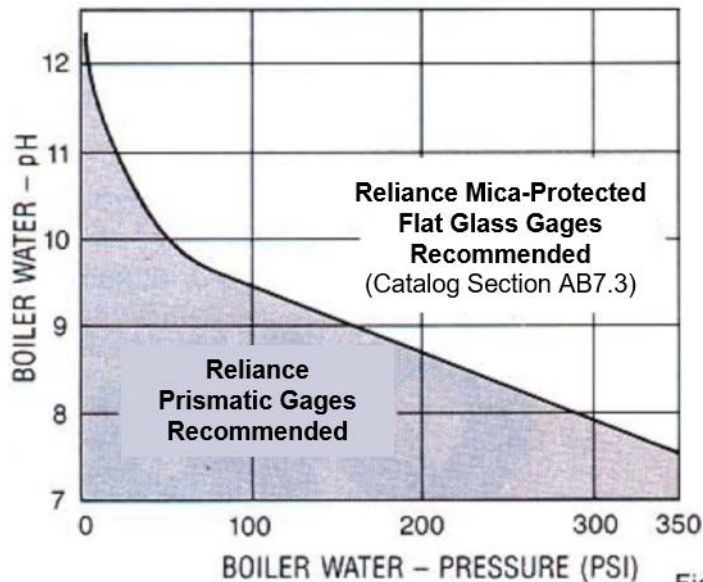

Figure 8

Reliance®

PRISMATIC GAGE ASSEMBLIES

PRISMATIC GAGES VERTICAL ASSEMBLIES



Figure 9

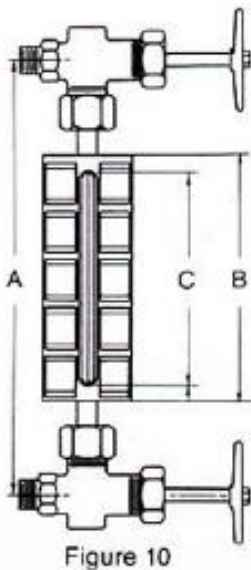

Figure 10

Gages with greater than 3 sections will be offered with flanged connections. Consult factory for assistance. See our bulletin #AB5.1D for more details on our companion Bronze Water Gage Valves.

Vertical Centers with Reliance Bronze Type Valves – in (mm) A	Prismatic Number		Vertical Water Visibility – in (mm) C	Overall Body Length – in (mm) B
	“C” Type	“S” Type		
14 (355.6)	C4	S4	6 ¼ (171.5)	7 1/8 (181)
16 (406.4)	C5	S5	7 7/8 (200)	9 (228.6)
17 (431.8)	C6	S6	9 1/8 (231.8)	10 ¼ (260.4)
18 (457.2)	C7	S7	10 1/8 (257.2)	11 3/8 (288.9)
19 (482.6)	C7	S7	10 1/8 (257.2)	11 3/8 (288.9)
19 ½ (495.3)	C8	S8	11 ¼ (298.5)	13 (330.2)
20 (508)	C9	S9	12 ½ (317.5)	13 ¼ (349.3)
21 (533.4)	C9	S9	12 ½ (317.5)	13 ¼ (349.3)
22 (558.8)	C9	S9	12 ½ (317.5)	13 ¼ (349.3)
23 (584.2)	C44	S44	14 7/8 (377.8)	16 (406.4)
24 (609.6)	C44	S44	14 7/8 (377.8)	16 (406.4)
25 (635)	C55	S55	17 1/8 (435)	18 ¼ (463.6)
26 (660.4)	C55	S55	17 1/8 (435)	18 ¼ (463.6)
27 (685.8)	C66	S66	19 5/8 (498.5)	20 ¼ (527.1)
28 (711.2)	C66	S66	19 5/8 (498.5)	20 ¼ (527.1)
29 (736.6)	C66	S66	19 5/8 (498.5)	20 ¼ (527.1)
30 (762)	C77	S77	21 ¼ (552.5)	23 (584.2)
31 (787.4)	C77	S77	21 ¼ (552.5)	23 (584.2)
32 (812.8)	C77	S77	21 ¼ (552.5)	23 (584.2)
33 (838.2)	C88	S88	25 (635)	26 ¼ (666.8)
34 (863.6)	C99	S99	26 ½ (673.1)	27 ¼ (704.9)
30 ¼ (768.4)	C444	S444	23 (584.2)	24 1/8 (612.8)
33 5/8 (854.1)	C555	S555	26 3/8 (670)	27 ¼ (698.5)
37 3/8 (949.3)	C666	S666	30 1/8 (765.2)	31 ¼ (793.8)
40 ¼ (1035.1)	C777	S777	33 3/8 (841.4)	34 5/8 (879.5)
45 5/8 (1158.9)	C888	S888	38 ¼ (971.6)	39 ¼ (1003.3)
47 7/8 (1216.1)	C999	S999	40 ¼ (1028.7)	41 ¼ (1060.5)

Reliance®

PRISMATIC GAGE ASSEMBLIES

PRISMATIC GAGES TILTVIEW ASSEMBLIES

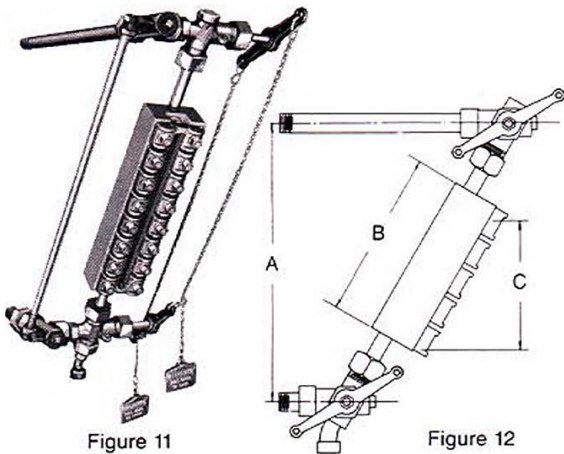

Figure 11

Figure 12

Vertical Centers with Reliance Bronze Type Valves – in (mm) A	Prismatic Number		Vertical Water Visibility – in (mm) C	Overall Body Length – in (mm) B
	“C” Type	“S” Type		
15 (381)	C6	S6	7 7/8 (200)	10 1/4 (260.4)
16 (406.4)	C7	S7	8 3/4 (222.3)	11 3/8 (289)
17 (431.8)	C8	S8	10 1/4 (260.4)	13 (330.2)
18 (457.2)	C9	S9	10 7/8 (276.2)	13 3/4 (349.3)
19 (482.6)	C9	S9	10 7/8 (276.2)	13 3/4 (349.3)
20 (508)	C44	S44	12 7/8 (327)	16 (406.4)
21 (533.4)	C44	S44	12 7/8 (327)	16 (406.4)
22 (558.8)	C55	S55	14 7/8 (377.8)	18 1/4 (463.6)
23 (584.2)	C55	S55	14 7/8 (377.8)	18 1/4 (463.6)
24 (609.6)	C66	S66	17 (431.8)	20 3/4 (527.1)
25 (635)	C66	S66	17 (431.8)	20 3/4 (527.1)
26 (660.4)	C77	S77	18 7/8 (479.4)	23 (584.2)
27 (685.8)	C77	S77	18 7/8 (479.4)	23 (584.2)
28 (711.2)	C77	S77	18 7/8 (479.4)	23 (584.2)
29 (736.6)	C88	S88	21 5/8 (549.3)	26 1/4 (666.8)
30 (762)	C99	S99	23 (584.2)	27 3/4 (704.9)

NOTES ON SPECIFYING RELIANCE PRISMATIC WATER GAGES

- When specifying Prismatic Gages, refer to the Vertical Valve Center dimension “A” in the tables provided. Locate the “A” dimension that corresponds to your own gage valve centers.
- The overall length of the Prismatic Gage, including nipples, is equal to a Tubular Glass gage length.
- A change to Prismatic Gages reduces the length of visible water range 3” to 6” depending upon gage and valve combinations.
- Gage-to-valve nipples are 3/4” diameter. Minimum length of top nipple is 1 3/4”. Minimum length of bottom nipple is 1 3/8” when Reliance bronze valves are used.

Reliance®

REPLACING TUBULAR GLASS & GAGE ILLUMINATION

PRISMATIC GAGES REPLACING TUBULAR GLASS

NOTE: When installing a Prismatic Gage to replace an existing tubular glass gage, a reduction in gage visibility can be avoided by installing an offset assembly. The offset assembly accepts a Prismatic Gage long enough to provide the necessary visibility, using valves rotated 90°. *When ordering, please specify gage valve centers and Reliance Water Column and Valve part numbers.*

Gage No.	C	A – Valve Centers			
		Prismatic		Flat Glass	
		Visible – in (mm)	Min. – in (mm)	Max. – in (mm)	Min. – in (mm)
4	6 ¾ (171.5)	9 3/8 (238.1)	13 3/8 (339.7)	9 ¾ (247.7)	13 ¾ (349.3)
5	7 7/8 (200)	10 ½ (266.7)	14 ½ (368.3)	10 7/8 (276.2)	14 7/8 (377.8)
6	9 1/8 (231.8)	11 ¾ (298.5)	15 ¾ (400)	12 1/8 (308)	16 1/8 (409.6)
7	10 1/8 (257.2)	12 7/8 (327)	16 7/8 (728.6)	13 1/8 (333.3)	17 1/8 (435)
8	11 ¾ (298.5)	14 ½ (368.3)	18 ½ (469.9)	14 ¾ (374.7)	18 ¾ (476.3)
9	12 ½ (317.5)	15 ¾ (387.4)	19 ¾ (489)	15 ¾ (393.7)	19 ½ (495.3)

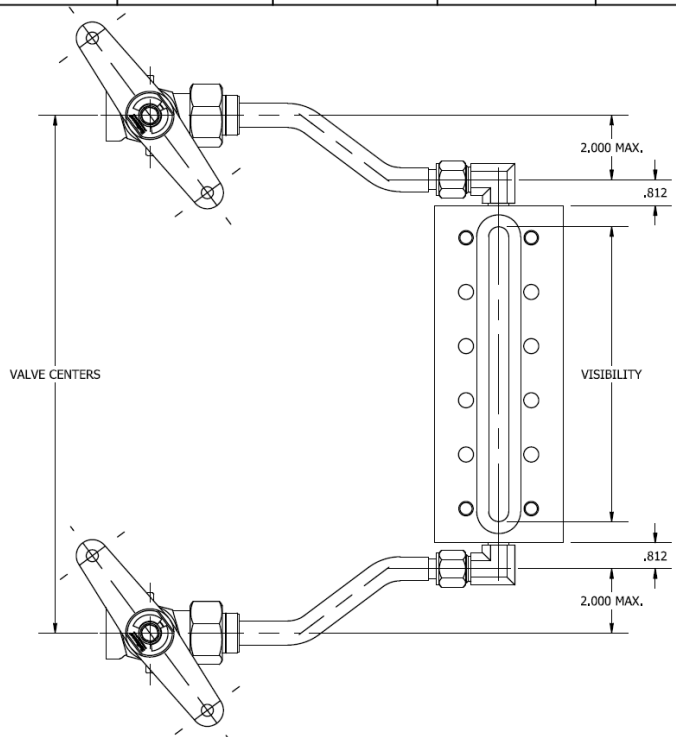

GAGE ILLUMINATION

Gage Illuminators are a helpful option. Model GL-53 uses a 9-watt LED lamp. For any assistance with your specifications, contact your nearest Reliance representative.

From the World's Largest Selection of Boiler Instrumentation and Control Devices



Eye-Hye® SmartLevel™
Local and Remote Indicators

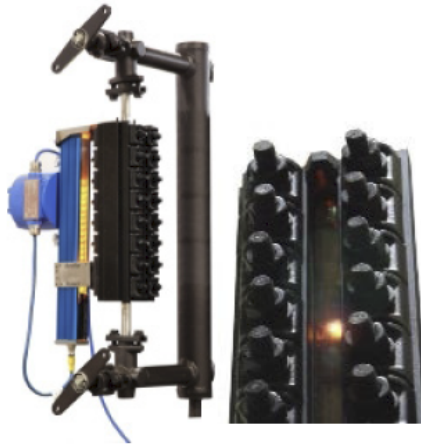

Flat Glass Gages and
DuraStar™ Illuminators



LevelMax™
Systems



Simpliport® 180
Water Gage System

Maintain Optimum Performance and
Accuracy with OEM Parts

Critical spare parts for overnight delivery,
direct from the manufacturer.



clark-reliance.com/parts



Clark-Reliance
CORPORATION

Authorised Distributor:

AMPMECH

46, Jalan SS 22/21, Damansara Jaya,
47400 Petaling Jaya,
Selangor Darul Ehsan, Malaysia.

Email: ampmech@ampmech.com
Website: www.ampmech.com