

Jerguson's Tri-Magnet Level Switches deliver failure-free performance.



(Series JX)



(Series JB)

The innovative use of repelling magnetic fields eliminates springs and other mechanical elements that are prone to failure in high temperatures, extreme vibration, or simply fatigue over time.

FEATURES

- Tri-Magnet Switching for Unparalleled Reliability
- Vibration Resistant
- Sealed or Flanged Cage
- 316 Stainless Steel Trim
- ASME B31.1 & B31.3 Design

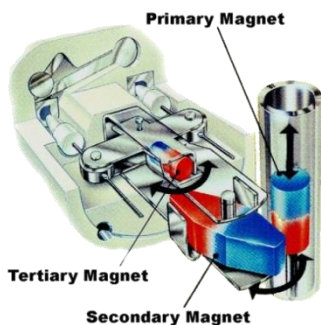

**Unique 3 magnet latching.
No springs...No problem.**

"The new switches are very rugged and dependable, and most importantly, they are mercury-free and safe for the environment. Dealing with spilled mercury is an extremely difficult task, but it is one we don't have to worry about with these new switches. The Jerguson Tri-Magnet Level Switches have been in operation in our facility since May 2007."

*-Maintenance Superintendent,
Major Utility Power Generation Plant*

The Tri-Magnet Level Switch was endurance tested to over 850,000 cycles without failure.

JERGUSON® LEVEL SWITCHES THE SWITCH MECHANISM

Principle of Operation

The switch mechanism is based on a unique three-dimensional magnet design where the snap action is accomplished by the utilization of magnetic repulsion and attraction. The primary magnet mounted on the float rod causes the secondary magnet to rotate as it passes up and down. The tertiary switch magnet is repelled by the secondary and snaps to the opposite side. This causes the cradle to pivot, moving the push rods, which operate the switch contacts. The result is positive snap action interlock switching...**no springs...no spring problems!**

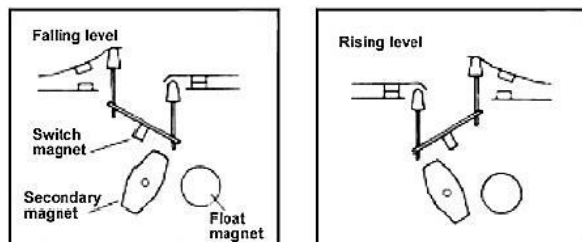
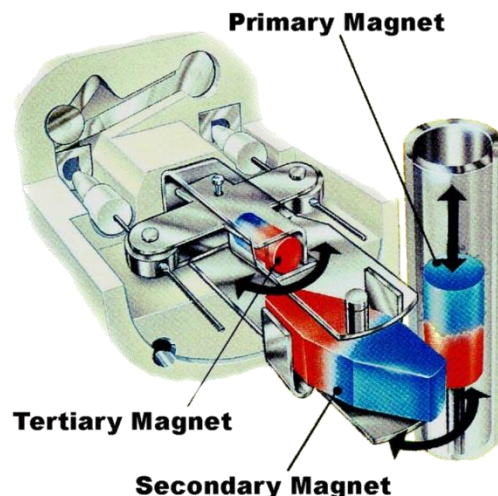

Schematic showing three-magnet system

Type	Choice of Switch Mechanisms
	Application
X4, X8	General purpose - 10 amp mechanisms for general purpose duties up to 480°F
D4, D8	High temperature - 5 amp mechanisms for high temperature applications up to 750°F
H4, H8	Hermetically sealed - 5 amp mechanisms suitable for temperatures up to 480°F, contaminated atmosphere environments and intrinsically safe circuits. All moving parts and contacts enclosed in an inert gas filled stainless steel enclosure.
P4, P8	Low current - 0.25 amp gold-plated contact switch mechanism for use in intrinsically safe or low power circuits up to 750°F
E4, E8	Encapsulated - 5 amp switch mechanism is sealed / encapsulated inside aluminum housing, suitable for temperatures to 850°F

4 Contact Type D4, X4, P4, H4, E4
2 x S.P.S.T
AA Make on Rise
BB Make on Fall
Link for SPDT/SPCO
8 Contact Type D8, X8, P8, H8, E8
D.P.D.T.
4 x S.P.S.T.
AA Make on Rise
BB Make on Fall
Link for DPDT/DPCO

THE FLOAT CHAMBER

Applications

The flanged chamber construction of this X series range of vertical controls makes them a very serviceable level control solution for petrochemical, power generation and OEM applications.

The unique three-magnet system provides reliable switching for applications such as level alarm, safety shutdown and pump control in product storage tanks, gas scrubbers, process vessels, and high pressure steam generators.

Single or multi-switch models are available. Chambers are designed to ASME B31.1, Power Piping Code, and ASME B31.3, Chemical Plant and Petroleum Refinery Piping Code.

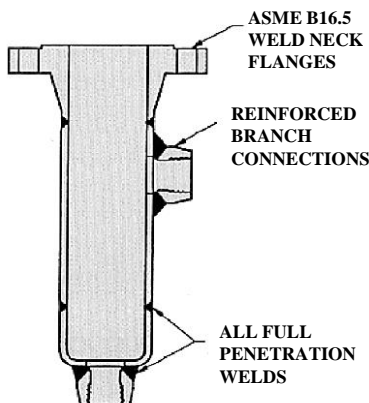

Options:

- Stainless Steel Chamber
- Low temperature chamber below -20°F
- High temperature chrome-moly chamber
- Certified to B31.1 or B31.3
- Non-destructive testing: radiographic, ultrasonic, magnetic particle, dye penetrant
- Epoxy paint finish (FP-18)
- Extended NEMA 4 switch enclosure housing up to 3 SPDT switch mechanisms or 3 DPDT switch mechanisms
- Vent connection
- Specific gravity below .35
- NACE specification MR-0175

DIMENSIONAL AND OPERATING LEVEL DATA

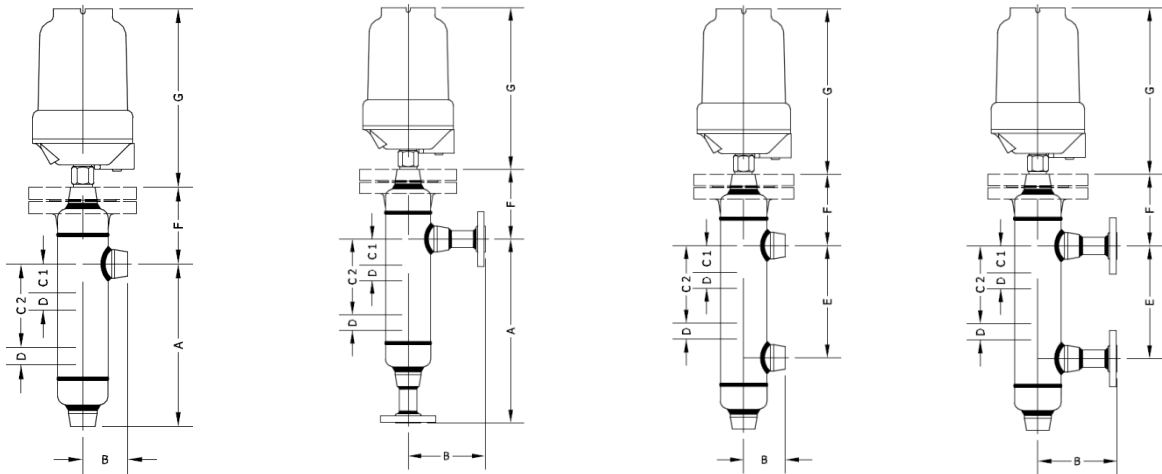

NOTE: All flange nipples are 1" NPS as standard

Model	A				B		C1	C2	D	E	F	
	Single Switch NPT/SW	Multi-Switch NPT/SW	Single Switch Flanged	Multi-Switch Flanged	NPT or S/W	Flanged	Hi Alarm	Multi-Switch	Ⓢ	C-C	Chamber Type B	Chamber Type X
JBC1F & JXC1F	8 1/2"	11 1/2"	14"	17"	3 1/4"	6"	2"	5"	0.56"	14"	5 1/2"	5 3/4"
JBC2F & JXC2F	10"	13"	14"	17"	3 3/4"	6 1/2"	2"	5"	0.56"	14"	6"	6"
JBC3F & JXC3F	10"	13"	14"	17"	3 3/4"	6 1/2"	2"	5"	0.56"	14"	6"	6 11/16"
JBC4F & JXC4F	10"	13"	14"	17"	3 3/4"	6 1/2"	2"	5"	0.56"	14"	6"	8 1/16"
JXC5F	10"	13"	14"	17"	3 3/4"	6 1/2"	2"	5"	0.56"	14"	6"	8 1/16"
JBC5F	9 1/2"	12 1/2"	14"	17"	4 1/4"	7 1/2"	2"	5"	0.56"	14"	6 1/2"	8 1/16"
JBC6F & JXC6F	10"	13"	14"	17"	4 3/4"	7 1/2"	2"	5"	0.56"	14"	7"	6 9/16"
JBC7F & JXC7F	10"	13"	14"	17"	4 3/4"	7 1/2"	2"	5"	0.56"	14"	7"	7 3/8"
JBC8F & JXC8F	10"	13"	14"	17"	4 3/4"	7 1/2"	2"	5"	0.56"	14"	7"	8 1/4"
JBC9F & JXC9F	12 1/2"	15 1/2"	16"	19"	5 3/4"	8 1/2"	2"	5"	0.56"	14"	7 1/2"	7 3/16"

Notes: 1) Flanged dimensions apply for R.F. process connections up to 2" - 600#.
 2) Switch actuation levels are at minimum S.G.
 3) C1 = Single Switch : Process C/L to rising trip point of switch.
 = Multi-Switch : Process C/L to rising trip point of upper/high level switch.
 4) C2 = Multi-Switch : Process C/L to rising trip point of lower/low level switch.
 5) D = Switch Deadband, Distance Between Rising Trip & Falling Reset.

All dimensions in inches. Dimensions are for reference only, and must be certified upon order. All dimensions based 1" reinforced fittings.

ENCLOSURE DIMENSIONAL DATA

Type	Duty	Height G	Conduit Thread	Switch Adjustment	Weatherproof Rating
SA7	Explosion-proof	13 1/4"	1" NPT	3 3/8"	NEMA 4 & 7
SA4	Weather-proof	12"	1" NPT	3 3/8"	NEMA 4

MATERIALS OF CONSTRUCTION

Technical Specifications	Designed in accordance with the requirements of B31.1 & B31.3. Pressure tested to 1.5 x maximum working pressures.	
Materials of Construction	Carbon Steel Chamber	Stainless Steel Chamber
Chamber Pipe	ASTM A106 GrB	ASTM A312 316
Top/Bottom Caps	ASTM A234	ASTM A403 WP-316
Flanges/Fittings	ASTM A105	ASTM A182F316
Studs	ASTM A193-B7	ASTM Z193-B7
Nuts	ASTM A194-2H	ASTM A194-2H
Float & Trim	316 SS	316 SS

OUR WARRANTY



All mechanical level devices are warranted free of defects in materials and workmanship for five years from the date of original factory shipment.

If returned within the stated warranty period, and upon factory inspection the cause of the claim is determined to be covered under the warranty, at option, the device will be repaired or replaced without cost to the purchaser (or owner), other than transportation.

Jerguson® shall not be liable for mis-application, labor claims, direct or consequential damage or expense arising from the installation or use of the equipment. There are no other warranties expressed or implied.

ORDERING INFORMATION

CHAMBER TYPE & MATERIAL OF CONSTRUCTION EXTERNAL CAGE SPECIFICATIONS

Carbon Steel		Stainless Steel		Carbon Steel		Stainless Steel			
JBC		JBS		JXC		JXS			
Float is sealed inside chamber during manufacturing. Not removable.				Float may be removed from chamber for routine maintenance, cleaning or inspection.					
JBC				JXC					
Model	Minimum S.G. SPDT	Minimum S.G. DPDT	Pressure Rating 100°F	Pressure Rating 750°F	Model	Minimum S.G. SPDT	Minimum S.G. DPDT	Pressure Rating 100°F	Pressure Rating 750°F
JBC1F	.70	.74	350	275	JXC1F	.70	.74	285	95
JBC2F	.55	.57	300	235	JXC2F	.55	.57	285	95
JBC3F	.60	.62	600	465	JXC3F	.60	.62	600	465
JBC4F	.70	.72	1440	935	JXC4F	.70	.72	740	505
JBC5F	.65	.67	1000	780	JXC5F	.70	.72	1440	935
JBC6F	.35	.37	300	235	JXC6F	.35	.37	285	95
JBC7F	.45	.47	750	585	JXC7F	.45	.47	740	505
JBC8F	.60	.62	1000	780	JXC8F	.60	.62	990	670
JBC9F	.34	.34	450	350	JXC9F	.34	.34	285	95

ENCLOSURE TYPES

Code	Duty	Material of cover		Material of base		Material of pressure	Material of screwed	Maximum number of switches
SA4N	Weather-proof	Aluminum Alloy				316 Stainless Steel	To match chamber material	2
SA7F	Explosion-proof Factory Mutual Cl.I, Div.1, Grps B,C & D	Drawn Steel	Aluminum Alloy					

NUMBER OF SWITCH MECHANISMS

Specify No. of Switches Required (1,2)

NOTES:

- Code design standard on all chambers unless otherwise specified.
- Code radiography is available upon request.
- Main Chamber:** Circumferential welds between center pipe & pipe cap(s), and weld neck chamber flange ("X" style 'Chamber Design' only), are full penetration, single-V, butt welds.
- Process Connections:** Immediate branch is an o'let. For flanged connections, when selected, a 1" NPS nipple is welded to the o'let, and slip-on flanges are welded to the nipple, as standard.
- Welders qualified to ASME IX. PWHT available upon request.

TYPICAL MODEL

JBC 4F SA4N 1 X4 1 2 F -

Design Options	
(Omitted)	Standard Design
WN	Weld Neck Flanges
SW	Socket Weld Flanges
RTJ	Ring Type Joint Flange
3E	3" Temperature Extension
6F	6" Temp. Extension w/ Cooling Fins
X	Special Design

Process Conn. Style	
F	FNPT
M	MNPT
S	FSW
P	Plain-End/MSW (Sch.80)
1	150#RFSO ASME
3	300#RFSO ASME
6	600#RFSO ASME
9	900#RFSO ASME
0	1500#RFSO ASME
(Omitted)	Replacement Head Ass'y, Less Chamber ("X" Chamber Design Style)

Process Conn. Size	
0	.50" (DN15)
1	.75" (DN20)
2	1.00" (DN25)
3	1.25" (DN32)
4	1.50" (DN40)
5	2.00" (DN50)
6	2.50" (DN65)
7	3.00" (DN80)
(Omitted)	Replacement Head Ass'y, Less Chamber ("X" Chamber Design Style)

PROCESS CONNECTION CONFIGURATION

1	Side & Bottom	2	Side & Side With Drain

Switch Mechanism

	Temp Wet-side °F	AC max. values			DC Max. values				
		VA	Volts	Amps	Watts	Volts	Res. Amps	Ind. Amps	
X4 D4 H4 E4 P4	 Link for SPDT Two independent single pole single throw contact sets	480	2000	440	10	50	250	10	0.5
		750	2000	440	5	50	250	5	0.5
		480	2000	440	5	50	250	5	0.5
		850	2000	440	5	50	250	5	0.5
X8 D8 H8 E8 P8	 Link for DPDT Four independent single pole single throw contact sets	480	2000	440	10	50	250	10	0.5
		750	2000	440	5	50	250	5	0.5
		480	2000	440	5	50	250	5	0.5
		850	2000	440	5	50	250	5	0.5
		750	6	250	0.25	3.6	250	0.25	0.1

Cage

Enclosure

No. of Switches

JERGUSON® "FIT & FORGET" PRODUCTS PROVIDE THE SOLUTION TO YOUR LIQUID LEVEL CONTROL PROBLEMS

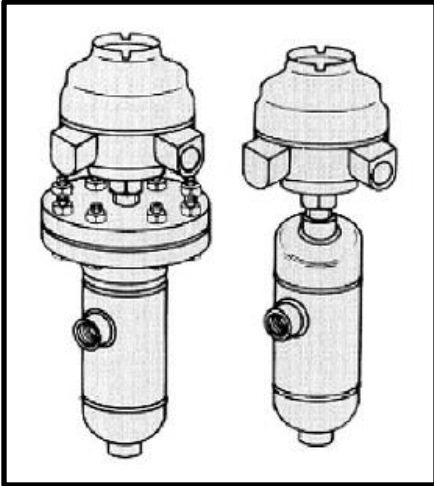

Medium Pressures
ASME Class 150, 300, 600
SG 0.40

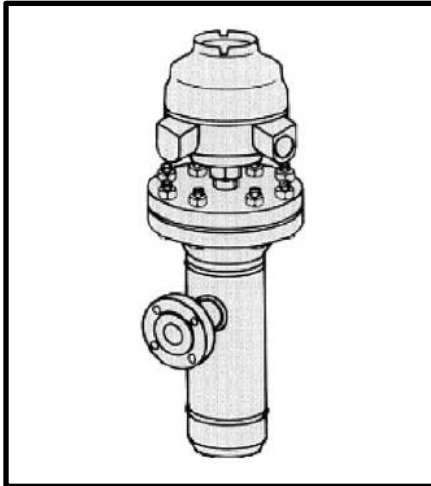

High Pressure
ASME Class 900, 1500, 2500
SG 0.40

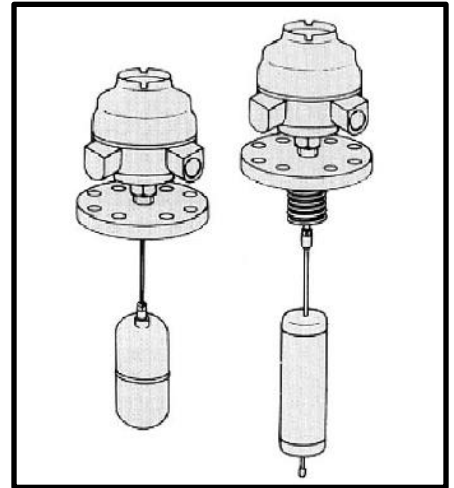

Direct Mounting
ASME Class 150, 300, 600
SG 0.40

You can rely on us

The Jerguson range of liquid level controls is designed for operation in a wide variety of applications.

Typical Applications

Separators	Water Sumps
Compressors	Scrubbers
Knock Out Pots	Fractioning Columns
Condensors	Process Vessels
De-actuators	Condensate Tanks
Storage Tanks	Drainpots
Service Tanks	Accumulators
Header Tanks	Flush Vessels
Effluent Sumps & Tanks	Fuel Tanks
Heat Exchanger	Feedwater Heaters
Lube Oil Tanks	Surge Drums

Jerguson level switches are used for the control of liquids by companies all over the world.

Shell	Bechtel
Exxon	Bellili
Amoco	Ontario Hydro
Fluor	Nissaci-Sangyo
Hyundai	Foster Wheeler
Hitachi	Siemens
British Petroleum	Mannesmann-Demag
Mobil	Catalytic
Texaco	Techni
Ingersoll Rand	Technipetrol
Compare	Nuovo Pignone
Honeywell	Dresser

Instrumentation & Control

JERGUSON®



Level Gages
Magnetic Level Gages
Switches & Valves

JACOBY·TARBOX®



Sight Flow Indicators
Sight Windows
Eductors

Reliance®



Boiler Level Gages
Remote Level Indicators
Boiler Safety Instruments

Filtration & Purification

ANDERSON® Separator



Gas Coalescing & Filtration
Steam Separators & Traps
Liquid Particle Filtration

Enervac™ INTERNATIONAL ULC



Transformer Oil Purification
SF6 Equipment
Air Dryers

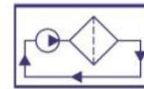

OIL FILTRATION SYSTEMS®



Vacuum Dehydrators
Varnish Removal Systems
Hi & Low Flow Filter Skids

Elements, Internals, Parts & More



www.clark-reliance.com / www.clark-reliance.com/parts