

Jerguson's Tri-Magnet Level Switches deliver failure-free performance.

The innovative use of repelling magnetic fields eliminates springs and other mechanical elements that are prone to failure in high temperatures, extreme vibration, or simply fatigue over time.

FEATURES

- Tri-Magnet Switching
- Vibration Resistant
- Sealed Cage
- ASME B31.1 Design
- ASME B31.3 Design
- Stainless Steel Trim

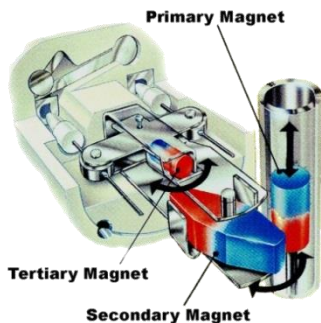

**Unique 3 magnet latching.
No springs...No problem.**

"The new switches are very rugged and dependable, and most importantly, they are mercury-free and safe for the environment. Dealing with spilled mercury is an extremely difficult task, but it is one we don't have to worry about with these new switches. The Jerguson Tri-Magnet Level Switches have been in operation in our facility since May 2007."

*-Maintenance Superintendent,
Major Utility Power Generation Plant*

The Tri-Magnet Level Switch was endurance tested to over 850,000 cycles without failure.

JERGUSON® LEVEL SWITCHES THE SWITCH MECHANISM

Principle of Operation

The switch mechanism is based on a unique three-dimensional magnet design where the snap action is accomplished by the utilization of magnetic repulsion and attraction. The primary magnet mounted on the float rod causes the secondary magnet to rotate as it passes up and down. The tertiary switch magnet is repelled by the secondary and snaps to the opposite side. This causes the cradle to pivot, moving the push rods, which operate the switch contacts. The result is positive snap action interlock switching...**no springs...no spring problems!**

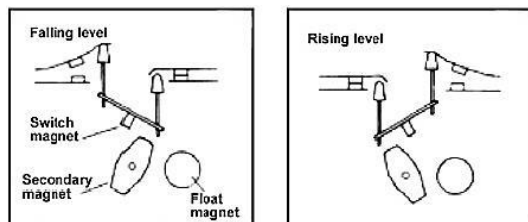
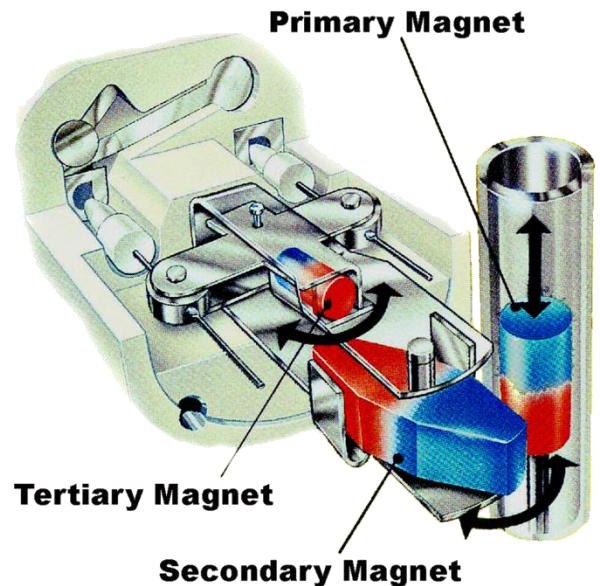

Schematic showing three-magnet system

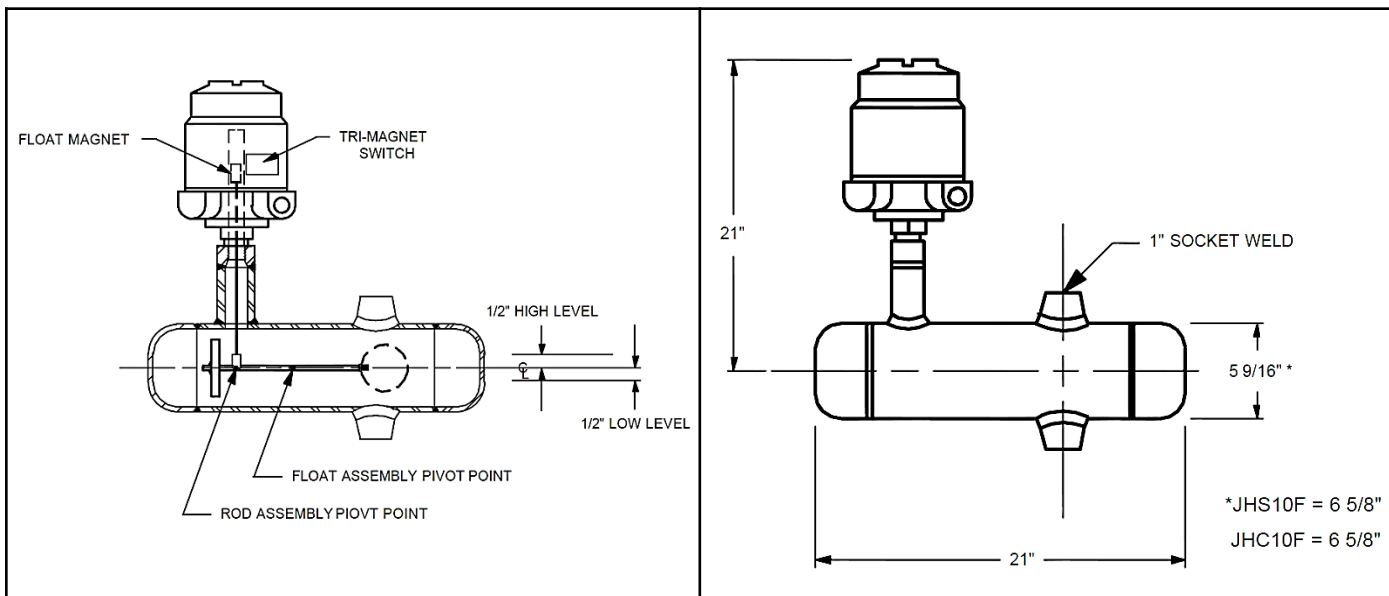

The JH Series is designed for high pressure/high temperature applications that are beyond the limitations of typical external cage vertical type float and displacer level switches. By utilizing a pivot and counter balance technique, the wall thickness of the float can be increased to handle higher pressure ratings. As the liquid rises and falls inside the chamber, the float assembly pivots causing the float magnet, which is attached to the rod assembly, to move in a downward or upward position. This movement causes the Tri-Magnet switch to actuate. The H series level switches can be used for a low level or high level installation. The unit is mounted relative to the actuation point from the centerline of the chamber.

ORDERING INFORMATION

TYPICAL MODEL

JHC8F SA4N 1D4 1 2 S _

Model No.	Material	Min. S.G.	Pressure Rating (PSIG)		
			@ 100°F	@ 750°F	@ 1000°F
JHC8F	Carbon Steel	0.60	1300	845	N/A
JHC9F	Carbon Steel	0.60	2095	1365	N/A
JHC10F	Carbon Steel	0.60	3790	2460	N/A
JHS8F	316-SST	0.60	1300	1045	N/A
JHS9F	316-SST	0.60	2095	1690	N/A
JHS10F	316-SST	0.60	3790	3050	N/A
JHH8F	High Alloy = 1 1/4 Cr - 1/2 Mo	0.60	1300	990	505
JHH9F	High Alloy = 1 1/4 Cr - 1/2 Mo	0.60	2095	1595	815
JHH10F	High Alloy = 1 1/4 Cr - 1/2 Mo	0.60	3790	2880	1475

See Note Below

Note: All JHH Models include dual temp extension and cooling fins.

Design Options	
(Omitted)	Standard Design
WN	Weld Neck Flanges
SW	Socket Weld Flanges
RTJ	Ring Type Joint Flange
3E	3" Temperatruue Extension
6F	6" Temp. Extension w/ Cooling Fins
X	Special Design

Process Conn. Style	
F	FNPT
M	MNPT
S	FSW
P	Plain-End/MSW (Sch.80)
1	150#RFSO ASME
3	300#RFSO ASME
6	600#RFSO ASSME
9	900#RFSO ASME
0	1500#RFSO ASME

¹Not available with all offerings, consult factory for applicability.

ENCLOSURE TYPES

Code	Duty	Material of cover	Material of base	Material of pressure	Material of screwed	Maximum number of switches
SA4N	Weather-proof	Aluminum Alloy		316 Stainless Steel	To match chamber material	1
SA7F	Explosion-proof Factory Mutual Cl.I,Div.1,Grps B,C & D	Drawn Steel	Aluminum Alloy			

SWITCH MECHANISM TYPES

Type	Max. Temp °F Standard Models	Max. Temp °F 6" Temp. Ext. + Cooling Fins	AC max. values				DC max. values			
			VA	Volts	Amps	Watts	Volts	Res. Amps	Ind. Amps	
1X4	480	1000	2000	440	10	50	250	10	0.5	
1D4	750	1000	2000	440	5	50	250	5	0.5	
1H4	480	850	2000	440	5	50	250	5	0.5	
1E4	850	1000	2000	440	5	50	250	5	0.5	
1P4	750	1000	6	250	0.25	3.6	250	0.25	0.1	
1X8	480	1000	2000	440	10	50	250	10	0.5	
1D8	750	1000	2000	440	5	50	250	5	0.5	
1H8	480	850	2000	440	5	50	250	5	0.5	
1E8	850	1000	2000	440	5	50	250	5	0.5	
1P8	750	1000	6	250	0.25	3.6	250	0.25	0.1	

Process Conn. Size	
0	.50" (DN15)
1	.75" (DN20)
2	1.00" (DN25)
3	1.25" (DN32)
4	1.50" (DN40)
5	2.00" (DN50)
6	2.50" (DN65)
7	3.00" (DN80)

Process Conn. Orientation	
1	Top-Bottom

- NOTES:**
- Code design standard on all chambers unless otherwise specified.
 - Code radiography is available upon request.
 - Main Chamber:** Circumferential welds between center pipe & pipe cap(s) are full penetration, single-V, butt welds. **Process Connections:** Immediate branch is an o'let. For flanged connections, when selected, a 1" NPS nipple is welded to the o'let, and slip-on flanges are welded to the nipple, as standard.
 - Welders qualified to ASME IX. PWHT available upon request.

Instrumentation & Control

JERGUSON®



Level Gages
Magnetic Level Gages
Switches & Valves

JACOBY·TARBOX®



Sight Flow Indicators
Sight Windows
Eductors

Reliance®



Boiler Level Gages
Remote Level Indicators
Boiler Safety Instruments

Filtration & Purification

ANDERSON® Separator



Gas Coalescing & Filtration
Steam Separators & Traps
Liquid Particle Filtration

Enervac™ INTERNATIONAL ULC



Transformer Oil Purification
SF6 Equipment
Air Dryers

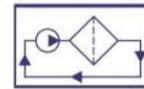

OIL FILTRATION SYSTEMS®



Vacuum Dehydrators
Varnish Removal Systems
Hi & Low Flow Filter Skids

Elements, Internals, Parts & More



www.clark-reliance.com / www.clark-reliance.com/parts