

Jerguson's Tri-Magnet Level Switches deliver failure-free performance.

The innovative use of repelling magnetic fields eliminates springs and other mechanical elements that are prone to failure due to high temperatures, extreme vibration, or fatigue over time.



FEATURES

- Tri-Magnet Switching for Unparalleled Reliability
- Vibration Resistant
- 316 Stainless Steel Trim
- ASME B31.1 & B31.3 Design

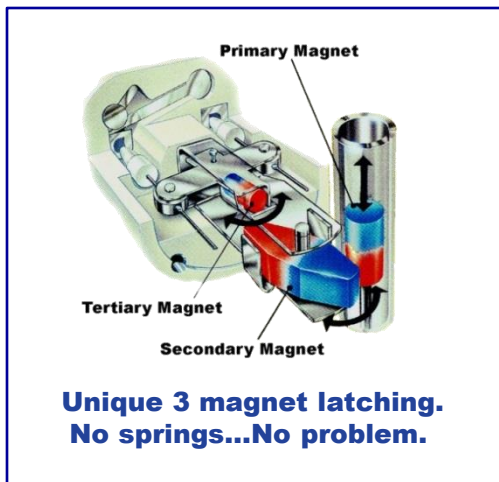

“The new switches are very rugged and dependable, and most importantly, they are mercury-free and safe for the environment. Dealing with spilled mercury is an extremely difficult task, but it is one we don't have to worry about with these new switches. The Jerguson Tri-Magnet Level Switches have been in operation in our facility since May 2007.”

*-Maintenance Superintendent,
Major Utility Power Generation Plant*

The Tri-Magnet Level Switch was endurance tested to over 850,000 cycles without failure.

JERGUSON® LEVEL SWITCHES THE SWITCH MECHANISM

Principle of Operation

The switch mechanism is based on a unique three-dimensional magnet design where the snap action is accomplished by the utilization of magnetic repulsion and attraction. The primary magnet mounted on the float rod causes the secondary magnet to rotate as it passes up and down. The tertiary switch magnet is repelled by the secondary and snaps to the opposite side. This causes the cradle to pivot, moving the push rods, which operate the switch contacts. The result is positive snap action, interlock switching...**no springs...no spring problems!**

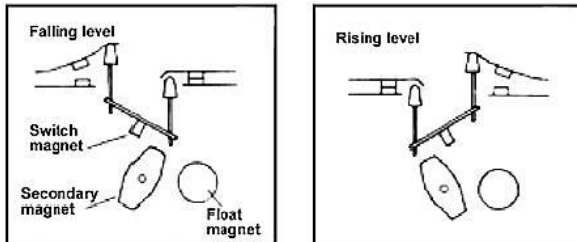
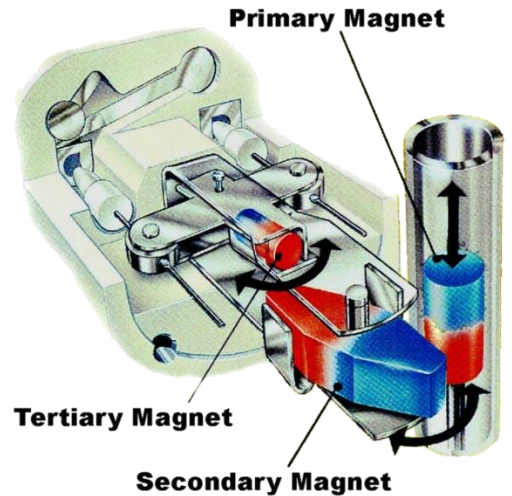

Schematic showing three-magnet system

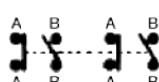
Type	Choice of Switch Mechanisms	Application	4 Contact Type D4, X4, P4, H4, E4
X4, X8	General purpose - 10 amp mechanisms for general purpose duties up to 480°F		S.P.D.T. 2 x S.P.S.T. AA Make on Fall BB Make on Rise 
D4, D8	High temperature - 5 amp mechanisms for high temperature applications up to 750°F		Link for SPDT/SPCO
H4, H8	Hermetically sealed - 5 amp mechanisms suitable for temperatures up to 480°F, contaminated atmosphere environments and intrinsically safe circuits. All moving parts and contacts enclosed in an inert gas filled stainless steel enclosure.		8 Contact Type D8, X8, P8, H8, E8
P4, P8	Low current - 0.25 amp gold-plated contact switch mechanism for use in intrinsically safe or low power circuits up to 750°F		D.P.D.T. 4 x S.P.S.T. AA Make on Fall BB Make on Rise 
E4, E8	Encapsulated - 5 amp switch mechanism is sealed / encapsulated inside aluminum housing, suitable for temperatures to 850°F		Link for DPDT/DPCO

THE FLOAT CHAMBER

Applications

The flanged chamber construction of this series of horizontal controls makes them a very serviceable level control solution for petrochemical, power generation and OEM applications.

The unique three-magnet system provides reliable switching for applications such as level alarm, safety shutdown and pump control in product storage tanks, gas scrubbers, process vessels, and high pressure steam generators.

Single switch only available. Chambers are designed to ASME B31.1, Power Piping Code, and ASME B31.3, Chemical Plant and Petroleum Refinery Piping Code.

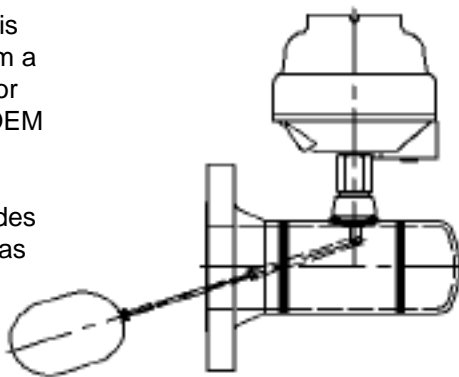

Options:

- Stainless Steel Chamber
- Low temperature chamber below -20°F
- High temperature chrome-moly chamber
- Certified to B31.1 or B31.3
- Non-destructive testing: radiographic, ultrasonic, magnetic particle, dye penetrant
- Epoxy paint finish (FP-18)
- Extended NEMA 4 switch enclosure housing 1 SPDT switch mechanisms or 1 DPDT switch mechanisms
- Vent connection
- Specific gravity down to 0.50
- NACE specification MR-0175

ORDERING INFORMATION

JHC1F SA7 1 X4

Model No.	Connection	Min. S.G.	Pressure Rating
	Carbon Steel		@ 100 Deg. F
JHC1F	3"-150# R.F.	0.60	285 PSIG @ 100°F, 95 PSIG @ 750°F
JHC2F	4"-150# R.F.	0.50	285 PSIG @ 100°F, 95 PSIG @ 750°F
JHC3F	4"-300# R.F.	0.50	600 PSIG @ 100°F, 465 PSIG @ 750°F
JHC4F	4"-300# R.F.	0.60	740 PSIG @ 100°F, 505 PSIG @ 750°F
JHC5F	4"-600# R.F.	0.60	1480 PSIG @ 100°F, 1015 PSIG @ 750°F
	Stainless Steel		
JHS1F	3"-150# R.F.	0.60	275 PSIG @ 100°F, 95 PSIG @ 750°F
JHS2F	4"-150# R.F.	0.50	275 PSIG @ 100°F, 95 PSIG @ 750°F
JHS3F	4"-300# R.F.	0.50	600 PSIG @ 100°F, 465 PSIG @ 750°F
JHS4F	4"-300# R.F.	0.60	720 PSIG @ 100°F, 425 PSIG @ 750°F
JHS5F	4"-600# R.F.	0.60	1440 PSIG @ 100°F, 855 PSIG @ 750°F

ENCLOSURE TYPES

Code	Duty	Material of cover	Material of base	Material of pressure	Material of screwed	Maximum number of switches
SA4N	Weather Proof	Aluminum Alloy		316 Stainless Steel	To match chamber material	1
SA7F	Explosion Proof – See Note ¹	Drawn Steel	Aluminum Alloy			

Note¹

Factory Mutual Approved:

Class I Division 1, Groups B, C, D; T6...T1 Ta = -50°C to +60°C; Type 4X, IP66/67

Class I, Zone 0**/1, AEx d IIC T6...T1 Ta = -50°C to +60°C, Type 4, IP66

** The equipment can be installed in the boundary wall between an area of Class I, Zone 0 and Class I, Zone 1.

In this configuration, the process connection is in Zone 0 and the enclosure is in Zone 1.

NUMBER OF SWITCHES

SWITCH MECHANISM

	Temp Wet-side °F	AC max. values			DC Max. values			
		VA	Volts	Amps	Watts	Volts	Res. Amps	Ind. Amps
X4	480	2000	440	10	50	250	10	0.5
D4								
H4	750	2000	440	5	50	250	5	0.5
E4	480	2000	440	5	50	250	5	0.5
P4	850	2000	440	5	50	250	5	0.5
	750	6	250	0.25	3.6	250	0.25	0.1
X8	480	2000	440	10	50	250	10	0.5
D8								
H8	750	2000	440	5	50	250	5	0.5
E8	480	2000	440	5	50	250	5	0.5
P8	850	2000	440	5	50	250	5	0.5
	750	6	250	0.25	3.6	250	0.25	0.1

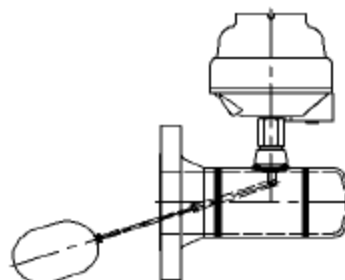
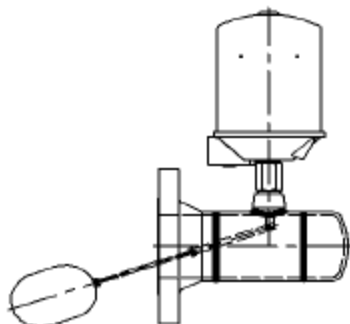

Instrumentation & Control

JERGUSON®



Level Gages
Magnetic Level Gages
Switches & Valves

JACOBY·TARBOX®



Sight Flow Indicators
Sight Windows
Eductors

Reliance®



Boiler Level Gages
Remote Level Indicators
Boiler Safety Instruments

Filtration & Purification

ANDERSON® Separator



Gas Coalescing & Filtration
Steam Separators & Traps
Liquid Particle Filtration

Enervac™ INTERNATIONAL ULC



Transformer Oil Purification
SF6 Equipment
Air Dryers

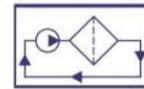

OIL FILTRATION SYSTEMS®



Vacuum Dehydrators
Varnish Removal Systems
Hi & Low Flow Filter Skids

Elements, Internals, Parts & More



www.clark-reliance.com / www.clark-reliance.com/parts