

RW400

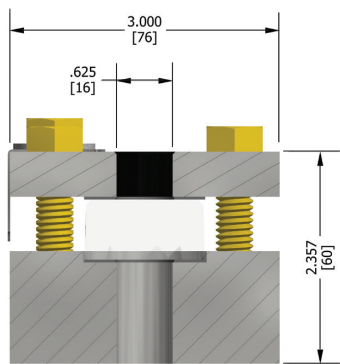

Series RW400

For Pressures Up To 400 PSI @ 400°F

Series RW400

Features

- Welded directly to the vessel
- User is responsible for performing pressure vessel calculations to determine if acceptable for ASME Sec.VIII
- Recessed Gasket Seat in Pad only
- Tempered Borosilicate Glass conforming to BS3463, JIS B8211, & Din 7081
- Wetted parts conforming to NACE MR0175 & MR0103 available
- All parts listed in ASTM or ASME

These weld pads are available with reflex type glass only. The pad features a 2-hole design which allows fluid to flow freely through the gage, provides more reinforcement when welded to the vessel and simplifies fabrication as the vessel wall only needs two thru-holes to match the pad vs. machining a slot. As an option, the pad can be machined with a radius to conform to the vessel O.D. The pad comes standard with a recessed gasket surface to provide lateral support and facilitate positioning during assembly. All weld pads are constructed from high quality materials listed in ASME Section II. The gages come complete with precision die cut gaskets and tempered borosilicate glass which conforms to DIN 7081. Weld pads are generally used for non-critical applications because the process must be shut down for gage maintenance or replacement.

Series RW-400

Size No.	Visible Range		Overall Length		Approximate Weight	
	in	mm	in	mm	lbs.	Kgs
11	3.750	95	5.250	133	9	4.1
12	4.750	121	6.250	159	11	5.0
13	5.750	146	7.250	184	12	5.5
14	6.750	171	8.250	210	14	6.4
15	7.875	200	9.375	238	16	7.3
16	9.125	232	10.625	270	18	8.2
17	10.250	260	11.750	298	20	9.1
18	11.875	302	13.375	340	22	10.0
19	12.625	321	14.125	359	24	10.9

To calculate visible range on multiple section gages use the single section value multiplied by the number of sections plus 1.5" for each additional section.

PRESSURE /TEMPERATURE RATINGS

Carbon Steel Pad					
Temperature		PSI		BarG	
Min.	Max.	Min.	Max.	Min.	Max.
-20°F (-28.8°C)	400°F (204.4°C)	Full Vacuum	400 PSI	Full Vacuum	27.5 BarG

PRESSURE /TEMPERATURE RATINGS

Stainless Steel Pad					
Temperature		PSI		BarG	
Min.	Max.	Min.	Max.	Min.	Max.
-320°F (-195.5°C)	400°F (204.4°C)	Full Vacuum	400 PSI	Full Vacuum	27.5 BarG

Liquid Level Gages

How to Specify Jerguson Weld Pad Gages

1 - 7 - RW20 - T - 2H - I - 3.312R - FS

Number of Sections
1 through 4

Glass Size (Gage Series)
1 through 9 (Series W20, W400) or
15, 18, 20 (Series W300L)

Glass Type & Gage Series

Code	Description
RW20	Reflex Series 20 Weld Pad
TW20	Transparent Series 20 Weld Pad
RW400	Reflex Series 400 Weld Pad
RW300L	Reflex Series 300L Weld Pad
TW300L	Transparent Series 300L Weld Pad

Material Code

Code	Description
A	Carbon Steel
T	316SS (wetted components) / Carbon Steel (non-wetted)
SP/T	All 316SS (both wetted and non-wetted components)
Other	Specify / Contact Factory

Pad Style

Code	Description
2H	2-Hole (Std. w/ Reflex Glass)
SL	Vision Slot Thru Pad (Std. w/ Transparent Glass)

Other Options

Code	Description
ISO	Isolable - Series W20 & Series W300L only
__SP	Steel Spacers for Welding (Specify # of Spacers)
FS	Foot/In Scale
MS	M/mm Scale

Chamber Radius

Code	Description
NR	No Radius = Flat Back
3.312R	Radius for 6" NPS (6.625" OD = 3.312"R)
4.312R	Radius for 8" NPS (8.625" OD = 4.312"R)
___ R	Other Radius (___ = Pad Radius, not NPS or Pipe OD)

Seal/Cushion Gasket

Code	Description
I	IFG5500 Seal & Cushion
G	Grafoil Seal, IFG5500 Cushion
GG	Gore Gr Seal (PTFE), IFG5500 Cushion
T	Teflon Seal, IFG5500 Cushion
Other	Specify / Contact Factory

Example Model: 1-7-RW20-T-2H-I-3.312R-FS

Code	Description
1	1 Section
7	Size 7 Glass
RW20	Reflex Series 20 Weld Pad
T	316SS (wetted components) / Carbon Steel (non-wetted)
2H	2-Hole Pad Style
I	IFG5500 Seal & Cushion Gasket
3.312R	Radius for 6" NPS Pipe
FS	Foot/In Scale

Authorised Distributor:



46, Jalan SS 22/21, Damansara Jaya,
47400 Petaling Jaya,
Selangor Darul Ehsan, Malaysia.

Email: ampmech@ampmech.com
Website: www.ampmech.com