



Color Indicator Ring Clearly Indicates Valve Status

- Run Mode (Green)
- Bypass Mode (Yellow)
- Closed (Red)

Innovative Core Design Locating an Internal Ballcheck within a Metal Seated Valve

Patented design eliminates operator error,
improves safety and reliability

- Improves safety by eliminating false level readings during commissioning
- Quarter turn position visible handle indicates open or closed
- Low emission certified to API 641 & ISO 15848-1
- Meets API Class V shut-off requirements
- 900# ANSI Pressure Rating
- All wetted components comply with NACE MR0103 and MR0175
- Clean-out port allows for quick inspection of internals or as a flushing port
- Lock-out / tag-out capable, standard

Innovative Design Guarantees Proper Commissioning

The Jerguson 360 Series valve is equipped with many features that elevate its performance above traditional style safety ballcheck valves. Designed to alleviate a widespread problem, the 360 Series' bypass mode seeks to remove guess work or operator error during commissioning. The quarter turn position — visible handle provides clear operation status and a locking pin to secure its position. **Patent # US9,377,113 B2**

Simplified Commissioning

As opposed to traditional ballcheck valves, it is impossible to get a false level reading with a 360 Series valve during commissioning. When using a traditional ballcheck valve and commissioning a gage assembly when there is already liquid present in the vessel, it is common for the operator to open the valve too quickly, causing the ballcheck to engage and the level gage to display a false level reading!



Simplified Commissioning: Visit www.jerguson.com/jerguson-360-series-safety-ballcheck-valve to view the video



With liquid present in the vessel, open the top valve to By-Pass position.



Then open the bottom valve to the bypass position. Fluid will now flow through the valve and into the glass without seating the ballcheck.

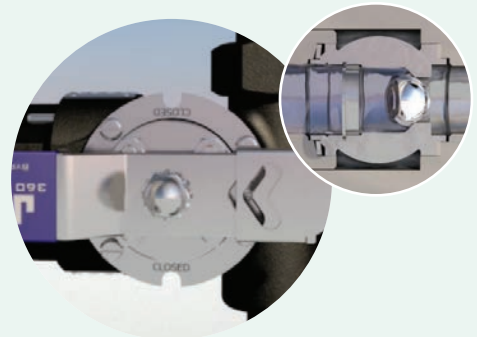

Once the level stops rising, move both valves to the run position. Now, the valves are ready for normal operation. If your level gage is not maintained properly or a leak occurs, the ballcheck will engage and isolate the gage from the vessel.

Liquid Level Valves

How to Specify 360 Series Safety Ballcheck Valves

Gage Connection Type

Code	Description
3S	Set, Non-Union Gage Connection
4S	Set, Union Gage Connection
3T	Top Valve, Non-Union Gage Connection
3B	Bottom Valve, Non-Union Gage Connection
4T	Top Valve, Union Gage Connection
4B	Bottom Valve, Union Gage Connection

Body Material

Code	Description
A	A105N Carbon Steel
T	A182 316/316L Stainless Steel
LC	Hastelloy C276

Trim Material

Code	Description
1	316SS Nitride Coated Seat & Ball; Inconel Stem
2	Hastelloy C276 Ball & Stem; Teflon Seat

Process Connection

Style Code	Description	Size Code	Description	Sizes Valid with Styles
A	FNPT	04	1/2" (DN15)	A, B, C, D, F, G
B	FSW	06	3/4" (DN20)	A, C, D, F, G
C	MNPT	08	1" (DN25)	C, D, F, G
D	MSW	12	1-1/2" (DN40)	F, G
F	RF ASME Flange	16	2" (DN50)	F, G
G	RF DIN Flange	00	N/A	K
K	No Connection			

364S-A-1-A04-A04-A04-A04--

Flange Class

Code	Description
01	150#
03	300#
06	600#
15	900/1500#

Options

Code	Description
Blank	Standard
WN	Weld Neck Flanges
RJ	Ring Joint Flanges
SG	Spherical Union Gage Connection

Clean-Out Connection Size

Code	Description	Note
A04	1/2" FNPT	Factory Default when 1/2" size vent/drain is specified
A06	3/4" FNPT	Factory Default when 3/4" size vent/drain is specified

*Contact factory for special connections

Vent or Drain Connection

Style Code	Description	Size Code	Description	Sizes Valid with Styles
A	FNPT	04	1/2" (DN15)	A, B, F, G
B	FSW	06	3/4" (DN20)	A, B, F, G
F	RF ASME Flange	08	1" (DN25)	F, G
G	RF DIN Flange	12	1-1/2" (DN40)	F, G
K	No Connection	16	2" (DN50)	F, G
		00	N/A	K

Carbon Steel

Series 360 Temperature / Pressure

Temp.		Pressure			
°F	°C	PSI	BarG	Kg/cm ²	kPaG
100	38	2220	153	156	15306
200	93	2035	140	143	14031
300	149	1965	135	138	13548
400	204	1900	131	134	13100
500	260	1810	125	127	12480
600	316	1705	118	120	11756
700	371	1590	110	112	10963
800	427	1235	85	87	8515

Not recommended for steam service

316SS

Series 360 Temperature / Pressure

Temp.		Pressure			
°F	°C	PSI	BarG	Kg/cm ²	kPaG
100	38	2160	149	152	14893
200	93	1860	128	131	12824
300	149	1680	116	118	11583
400	204	1540	106	108	10618
500	260	1435	99	101	9894
600	316	1355	93	95	9342
700	371	1305	90	92	8998
800	427	1265	87	89	8722

Not recommended for steam service

Gage Connection

Style Code	Description	Size Code	Description	363 Sizes Valid with Styles	364 Sizes Valid with Styles
A	FNPT	04	1/2" (DN15)	A, B, F, G	A, B, C, D, F, G
B	FSW	06	3/4" (DN20)	A, B, F, G	A, C, D, F, G
C	MNPT	08	1" (DN25)	F, G	C, D, F, G
D	MSW	12	1-1/2" (DN40)	F, G	F, G
F	RF ASME Flange	16	2" (DN50)	F, G	F, G
G	RF DIN Flange	00	N/A	K	K
K	No Connection				

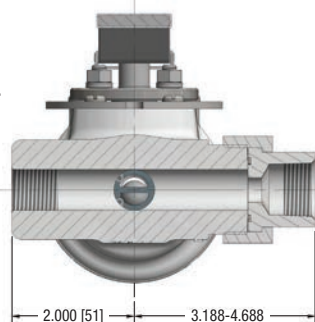
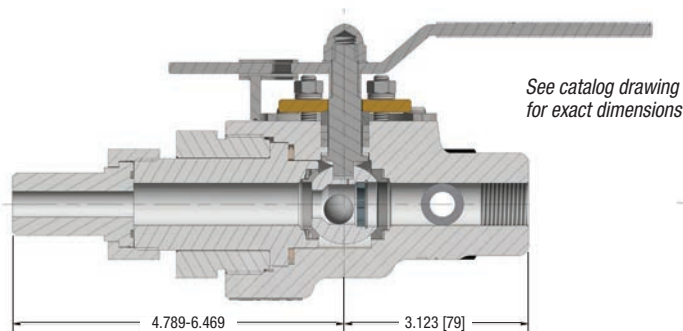

Authorised Distributor:



46, Jalan SS 22/21, Damansara Jaya,
47400 Petaling Jaya,
Selangor Darul Ehsan, Malaysia.

Email: ampmech@ampmech.com
Website: www.ampmech.com