



Reflex
R-20

Transparent
T-20

TEST PRESSURE: All gages are hydrostatically tested by Jerguson prior to shipment @ 1 1/2 times the design pressure rating at 100°F (38°C).

For Pressures Up to 3270 PSI @ 100°F

Series 20

Features

- Recessed Gasket Seat in Chamber and Cover
- Tempered Borosilicate Glass conforming to BS3463, JIS B8211, & DIN 7081
- Wetted Parts conform to NACE MR0175 & MR0103
- All parts listed in ASTM & ASME B31.3
- ABS Certified
- Carbon Steel Covers are Shrouded to Protect the Glass Edges
- All Gages feature a continuous, one-piece chamber regardless of length

The Jerguson Series 20 gage is the most common gage specified and will cover 80-85% of applications encountered. Important features include a recessed gasket surface (standard on all gage series) and shrouded covers. A recessed gasket surface provides positive location of the seal gasket during both assembly and field repair and also makes it possible to repair a Jerguson gage while it is mounted to the vessel. The recessed gasket surface is also an important safety feature in the fact that it contains the gasket and helps prevent lateral movement which could lead to a gasket blow-out (as with competitive gages.)

PRESSURE / TEMPERATURE RATINGS, PSI

Temperature		R-20 REFLEX GAGE								
		Glass Size								
°F	°C	1	2	3	4	5	6	7	8	9
100	38	3270	3140	3000	2880	2750	2630	2510	2390	2250
200	93	3090	2970	2860	2740	2620	2500	2380	2260	2150
300	149	2900	2790	2670	2560	2450	2340	2220	2110	2000
400	204	2700	2600	2490	2380	2270	2170	2060	1950	1850
500	260	2510	2410	2305	2205	2100	2000	1900	1800	1700
600	316	2285	2190	2100	2010	1915	1820	1730	1640	1550
For temperatures above 600°F (316°C) Aluminosilicate Glass must be used										
700	371	2080	1990	1910	1820	1740	1650	1570	1480	1400
800	427	1870	1790	1720	1640	1560	1480	1410	1330	1250
Saturated Steam Rating 300 WSP										

NOTE: Flanged gages are derated to flange rating, if applicable.

Temperature		T-20 TRANSPARENT GAGE								
		Glass Size								
°F	°C	1	2	3	4	5	6	7	8	9
100	38	2000	1850	1750	1600	1500	1350	1250	1100	1000
200	93	1900	1780	1660	1550	1440	1300	1175	1060	950
300	149	1770	1660	1550	1450	1330	1220	1100	1000	900
400	204	1675	1575	1470	1350	1250	1150	1050	925	850
500	260	1530	1450	1350	1250	1150	1050	950	850	750
600	316	1350	1275	1180	1100	1010	925	850	750	675
For temperatures above 600°F (316°C) Aluminosilicate Glass must be used										
700	371	1220	1140	1070	990	920	840	760	690	610
800	427	1100	1030	960	890	820	750	690	620	550
Saturated Steam Rating with MICA										
		600	600	600	600	550	500	450	400	350

Saturated Steam Rating 300 WSP NOTE: Flanged gages are derated to flange rating, if applicable.

PRESSURE / TEMPERATURE RATINGS, BarG

Temperature		R-20 REFLEX GAGE								
		Glass Size								
°F	°C	1	2	3	4	5	6	7	8	9
100	38	225.5	216.5	206.8	198.6	189.6	181.3	173.1	164.8	155.1
200	93	213.0	204.8	197.2	188.9	180.6	172.4	164.1	155.8	148.2
300	149	199.9	192.4	184.1	176.5	168.9	161.3	153.1	145.5	137.9
400	204	186.2	179.3	171.7	164.1	156.5	149.6	142.0	134.4	127.6
500	260	173.1	166.2	158.9	152.0	144.8	137.9	131.0	124.1	117.2
600	316	157.5	151.0	144.8	138.6	132.0	125.5	119.3	113.1	106.9
For temperatures above 600°F (316°C) Aluminosilicate Glass must be used										
700	371	143.4	137.2	131.7	125.5	120.0	113.8	108.2	102.0	96.5
800	427	128.9	123.4	118.6	113.1	107.6	102.0	97.2	91.7	86.2
Saturated Steam Rating 300 WSP										

NOTE: Flanged gages are derated to flange rating, if applicable.

Temperature		T-20 TRANSPARENT GAGE								
		Glass Size								
°F	°C	1	2	3	4	5	6	7	8	9
100	38	137.9	127.6	120.7	110.3	103.4	93.1	86.2	75.8	68.9
200	93	131.0	122.7	114.5	106.9	99.3	89.6	81.0	73.1	65.5
300	149	122.0	114.5	106.9	100.0	91.7	84.1	75.8	68.9	62.1
400	204	115.5	108.6	101.4	93.1	86.2	79.3	72.4	63.8	58.6
500	260	105.5	100.0	93.1	86.2	79.3	72.4	65.5	58.6	51.7
600	316	93.1	87.9	81.4	75.8	69.6	63.8	58.6	51.7	46.5
For temperatures above 600°F (316°C) Aluminosilicate Glass must be used										
700	371	84.1	78.6	73.8	68.3	63.4	57.9	52.4	47.6	42.1
800	427	75.8	71.0	66.2	61.4	56.5	51.7	47.6	42.7	37.9
Saturated Steam Rating with MICA										
		41.4	41.4	41.4	41.4	37.9	34.5	31.0	27.6	24.1

Saturated Steam Rating 300 WSP NOTE: Flanged gages are derated to flange rating, if applicable.

Liquid Level Gages

Series R-20 Reflex, Series T-20 Transparent

Sect. X Size	Visible Range		Overall Length (End Connected Gage Only)		Approximate Weight			
	in	mm	in	mm	Reflex, R-20		Transp., T-20	
					lbs.	Kgs	lbs.	Kgs
11	3.750	95	5.250	133	9	4.1	13	5.9
12	4.750	121	6.250	159	10	4.5	15	6.8
13	5.750	146	7.250	184	12	5.5	17	7.7
14	6.750	171	8.250	210	13	5.9	20	9.1
15	7.875	200	9.375	238	15	6.8	22	10.0
16	9.125	232	10.625	270	17	7.7	25	11.4
17	10.250	260	11.750	298	19	8.6	28	12.7
18	11.875	302	13.375	340	21	9.5	31	14.1
19	12.625	321	14.125	359	22	10.0	33	15.0
23	13.000	330	14.500	368	23	10.5	35	15.9
24	15.000	381	16.500	419	27	12.3	39	17.7
25	17.250	438	18.750	476	29	13.2	44	20.0
26	19.750	502	21.250	540	34	15.5	50	22.7
27	22.000	559	23.500	597	37	16.8	55	25.0
28	25.250	641	26.750	679	42	19.1	62	28.2
29	26.750	679	28.250	718	44	20.0	65	29.5
36	30.375	772	31.875	810	50	22.7	75	34.1
37	33.750	857	35.250	895	56	25.5	82	37.3
38	38.625	981	40.125	1019	63	28.6	93	42.3
39	40.875	1038	42.375	1076	66	30.0	98	44.5
47	45.500	1156	47.000	1194	74	33.6	109	49.5
48	52.000	1321	53.500	1359	84	38.2	124	56.4
49	55.000	1397	56.500	1435	88	40.0	130	59.1
57	57.250	1454	58.750	1492	93	42.3	137	62.3
58	65.375	1661	66.875	1699	105	47.7	155	70.5
59	69.125	1756	70.625	1794	111	50.5	163	74.1
68	78.750	2000	80.250	2038	126	57.3	186	84.5
69	83.250	2115	84.750	2153	133	60.5	196	89.1
78	92.125	2340	93.625	2378	147	66.8	217	98.6
79	97.375	2473	98.875	2511	155	70.5	228	103.6
88	105.500	2680	107.000	2718	169	76.8	248	112.7
89	111.500	2832	113.000	2870	177	80.5	261	118.6
98	118.875	3019	120.375	3058	190	86.4	279	126.8
99	125.625	3191	127.125	3229	199	90.5	294	133.6

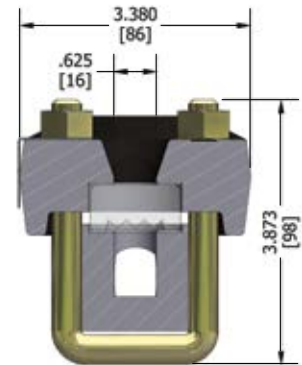

Series R-20 Reflex

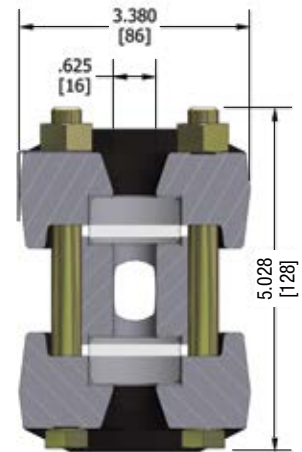

Series T-20 Transparent



CE models available

Specifications (See page 3 for Specifying Information)

SECTION LENGTHS

Gage sections are available in nine standard glass sizes. Longer sizes are constructed with multiple vision slots in a continuous solid bar chamber.

CONNECTIONS

Standard connections are at top and bottom and are 1/2" or 3/4" NPT female. Optional connections are available, such as socket weld, flanged or close hook-up (side/side).

LIQUID CHAMBER

Machined from bar stock. The gasket seat is recessed to provide lateral support, and facilitate positioning of the gasket. This seat aids in field repair, and enhances safety/reliability.

COVERS

Forged carbon steel shrouded covers are standard with optional materials available. The cushion gasket surface is recessed on all covers.

BOLTS & NUTS

Steel fasteners, heat treated for strength; A193 B7 bolts / A194 2H nuts. NACE options include A193 B7M bolts / A194 2HM nuts (Transparent only) and A193 B8M bolts / A194 8M nuts (316 Stainless Steel).

GLASS

Tempered Borosilicate is used to 600°F (316°C). Aluminosilicate is used to 800°F (427°C). Transparent glass may be protected from corrosive media with mica or Neoflon PCTFE shields.

GASKETS

Standard gaskets are precision die cut in proprietary Jerguson® dies.

FINISH

All carbon steel parts are finish coated prior to assembly with Jerguson Protective FP-16. Optional coatings such as FP-11 offshore available.

VALVES

Use of Jerguson gage valves is strongly recommended. Standard features include safety ballchecks which help prevent loss of product and physical injury in the event of a catastrophic failure.

Glass Types & Sizes

Glass Materials

- Borosilicate
 - Up to 600°F (316°C)
 - Up to 300 WSP
 - Over 300 WSP, Mica Protected Transparent Glass Only
- HP Borosilicate
 - Up to 600°F (316°C)
 - Higher Tolerances
- Aluminosilicate
 - Up to 800°F (426°C)

Glass Sizes – Industry Standard 34mm
 Sizes 1 thru 9 (All models except 300L)

Size	Length	Typical Visible Range
1	4-1/2" (115mm)	3-3/4" (95mm)
2	5-1/2" (140mm)	4-3/4" (121mm)
3	6-1/2" (165mm)	5-3/4" (146mm)
4	7-1/2" (190mm)	6-3/4" (171mm)
5	8-5/8" (220mm)	7-7/8" (200mm)
6	9-7/8" (250mm)	9-1/8" (232mm)
7	11" (280mm)	10-1/4" (260mm)
8	12-5/8" (320mm)	11-7/8" (302mm)
9	13-3/8" (340mm)	12-5/8" (321mm)



Glass Sizes – Jerguson 25mm
 Sizes 11 thru 20 (Series 300L - Obsolete 5 & 12)

Size	Length	Typical Visible Range
11	11" (280mm)	10-1/4" (260mm)
12	12" (305mm)	11-1/4" (286mm)
13	13" (330mm)	12-1/4" (311mm)
15	15" (381mm)	14-1/4" (362mm)
18	18" (457mm)	17-1/4" (438mm)
20	20" (508mm)	19-1/4" (489mm)

Specification

Materials of Construction

- Borosilicate Glass
- Gaskets
 - IFG® -5500 Standard (Seal/Cushion)
 - Graphite, with .002" (.05mm) stainless steel reinforcement layer
 - Teflon®
 - Other Materials Available

Chamber

- Carbon Steel
 - To -20°F (-28°C)
- Low Temp Carbon Steel
 - To -50°F (-45°C)
 - Charpy Impact Tested
 - B7M Bolts / 2HM Nuts
- Stainless Steel
 - To -325°F (-198°C)
 - Dual Rated 316/316L
- All Acceptable for NACE Service

Shields

Shields are used to protect the glass from chemical attack. Two shields are available: Mica and PCTFE.

Mica: Mica shields are used to protect the glass from corrosion in high pressure steam (over 300WSP) and caustic applications (pH >11).
 PCTFE: PCTFE shields (formerly known as Kel-F®) are primarily used in Hydrofluoric Acid service. Note that the PCTFE shield also serves as the sealing gasket; no additional sealing gasket is required.



Gage Code for Jerguson Gages

Special Features
 M = Mica Shield
 K = PCTFE (Kel-F) Shield
 F = Non-frosting
 H = External Heating
 E = Electrical Heating
 T = Internal Heating
 CH = Close Hook-up (Side or Back Conns.)
 W = Weld Pad
 IW = Isolable Weld Pad

Glass Size
 Series 300L:
 11, 12, 13,
 15, 18, 20

Other Series:
 1 thru 9

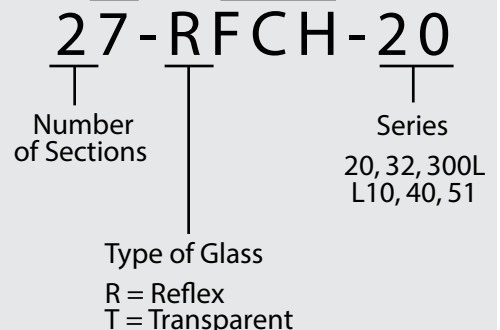

Gasket Materials— Standard Offering

Material	Min. Temperature	Max. Temperature	Rating Factor
Garlock IFG-5500	-40°F (-40°C)	550°F (288°C)	100%
25% Glass Filled TFE	-328°F (-200°C)	500°F (260°C)	100%
Grafoil	-400°F (-240°C)	800°F (427°C)	100%
PCTFE (Kel-F) Shield	-400°F (-240°C)	302°F (150°C)	50%