



Reflex
R-32



Transparent
T-32

For Pressures Up To 4000 PSI @ 100 °F

Series 32

Features

- Recessed Gasket Seat in Chamber and Cover
- Tempered Borosilicate Glass conforming to BS3463, JIS B8211, & DIN 7081
- Wetted Parts conform to NACE MR0175 & MR0103
- All parts listed in ASTM & ASME B31.3
- ABS Certified
- Carbon Steel Covers are Shrouded to Protect the Glass Edges
- All Gages feature a continuous, one-piece chamber regardless of length

A Series 32 gage appears very similar to a Series 20, except the Series 32 gage features mid-span supports or tie-bars to allow for increased pressure ratings. Note that the mid-span support is recessed. This is very important as other brands do not recess their mid-span support which causes a blind spot in the vision. A recessed gasket surface provides positive location of the seal gasket during both assembly and field repair and also makes it possible to repair a Jerguson gage while it is mounted to the vessel. The recessed gasket surface is also an important safety feature in the fact that it contains the gasket and helps prevent lateral movement which could lead to a gasket blow-out (as with competitive gages).

PRESSURE / TEMPERATURE RATINGS, PSI (BarG)

REFLEX GAGE Glass Size 1-9			
Temperature °F	°C	PSI	BarG
100	38	4000	275.8
200	93	3890	268.2
300	149	3790	261.3
400	204	3700	255.1
500	260	3470	239.2
600	316	3080	212.4
For temperatures above 600°F (316°C) Aluminosilicate Glass must be used			
700	371	2690	185.5
800	427	2300	158.6
Saturated Steam Rating 300 WSP			

TRANSPARENT GAGE Glass Size 1-9			
Temperature °F	°C	PSI	BarG
100	38	3000	206.8
200	93	2920	201.3
300	149	2850	196.5
400	204	2780	191.7
500	260	2600	179.3
600	316	2310	159.3
For temperatures above 600°F (316°C) Aluminosilicate Glass must be used			
700	371	2020	139.3
800	427	1730	119.3
Saturated Steam Rating 750 WSP			

NOTE: Flanged gages are derated to flange rating, if applicable.

TEST PRESSURE: All gages are hydrostatically tested by Jerguson prior to shipment @ 1 1/2 times the design pressure rating at 100°F (38°C).

Liquid Level Gages

Series R-32 Reflex, Series T-32 Transparent

Sect. X Size	Visible Range		Overall Length (End Connected Gage Only)		Approximate Weight			
	in	mm	in	mm	Reflex, R-32		Transp., T-32	
					lbs.	Kgs	lbs.	Kgs
11	3.750	95	5.250	133	9	4.1	13	5.9
12	4.750	121	6.250	159	10	4.5	15	6.8
13	5.750	146	7.250	184	12	5.5	17	7.7
14	6.750	171	8.250	210	13	5.9	20	9.1
15	7.875	200	9.375	238	15	6.8	22	10.0
16	9.125	232	10.625	270	17	7.7	25	11.4
17	10.250	260	11.750	298	19	8.6	28	12.7
18	11.875	302	13.375	340	21	9.5	31	14.1
19	12.625	321	14.125	359	22	10.0	33	15.0
23	13.000	330	14.500	368	23	10.5	35	15.9
24	15.000	381	16.500	419	27	12.3	40	18.2
25	17.250	438	18.750	476	30	13.6	44	20.0
26	19.750	502	21.250	540	34	15.5	50	22.7
27	22.000	559	23.500	597	38	17.3	56	25.5
28	25.250	641	26.750	679	42	19.1	63	28.6
29	26.750	679	28.250	718	45	20.5	66	30.0
36	30.375	772	31.875	810	51	23.2	76	34.5
37	33.750	857	35.250	895	56	25.5	84	38.2
38	38.625	981	40.125	1019	64	29.1	94	42.7
39	40.875	1038	42.375	1076	67	30.5	99	45.0
47	45.500	1156	47.000	1194	75	34.1	112	50.9
48	52.000	1321	53.500	1359	85	38.6	126	57.3
49	55.000	1397	56.500	1435	89	40.5	133	60.5
57	57.250	1454	58.750	1492	94	42.7	140	63.6
58	65.375	1661	66.875	1699	106	48.2	158	71.8
59	69.125	1756	70.625	1794	111	50.5	166	75.5
68	78.750	2000	80.250	2038	128	58.2	189	85.9
69	83.250	2115	84.750	2153	134	60.9	199	90.5
78	92.125	2340	93.625	2378	149	67.7	221	100.5
79	97.375	2473	98.875	2511	156	70.9	233	105.9
88	105.500	2680	107.000	2718	170	77.3	253	115.0
89	111.500	2832	113.000	2870	178	80.9	266	120.9
98	118.875	3019	120.375	3058	190	86.4	279	126.8
99	125.625	3191	127.125	3229	199	90.5	294	133.6

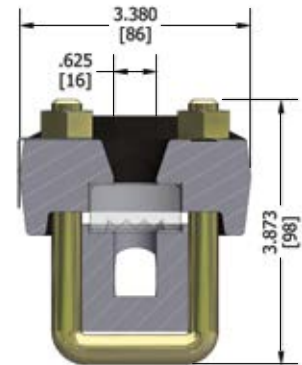

Series R-32 Reflex

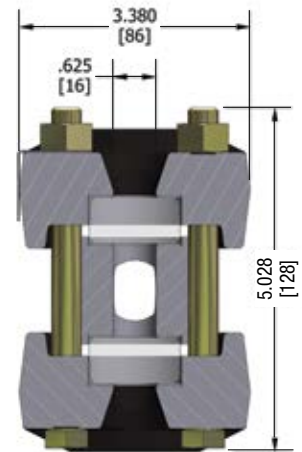

Series T-32 Transparent



CE models available

Specifications (See page 3 for Specifying Information)

SECTION LENGTHS

Gage sections are available in nine standard glass sizes. Longer sizes are constructed with multiple vision slots in a continuous solid bar chamber.

CONNECTIONS

Standard connections are at top and bottom and are 1/2" or 3/4" NPT female. Optional connections are available, such as socket weld, flanged or close hook-up (side/side).

LIQUID CHAMBER

Machined from bar stock. The gasket seat is recessed to provide lateral support, and facilitate positioning of the gasket. This seat aids in field repair, and enhances safety/reliability.

COVERS

Forged carbon steel shrouded covers are standard with optional materials available. The cushion gasket surface is recessed on all covers.

BOLTS & NUTS

Steel fasteners, heat treated for strength; A193 B7 bolts / A194 2H nuts. NACE options include A193 B7M bolts / A194 2HM nuts (Transparent only) and A193 B8M bolts / A194 8M nuts (316 Stainless Steel).

GLASS

Tempered Borosilicate is used to 600°F (316°C). Aluminosilicate is used to 800°F (427°C). Transparent glass may be protected from corrosive media with mica or Neoflon PCTFE shields.

GASKETS

Standard gaskets are precision die cut in proprietary Jerguson® dies.

FINISH

All carbon steel parts are finish coated prior to assembly with Jerguson Protective FP-16. Optional coatings such as FP-11 offshore available.

VALVES

Use of Jerguson gage valves is strongly recommended. Standard features include safety ballchecks which help prevent loss of product and physical injury in the event of a catastrophic failure.

Glass Types & Sizes

Glass Materials

- Borosilicate
 - Up to 600°F (316°C)
 - Up to 300 WSP
 - Over 300 WSP, Mica Protected Transparent Glass Only
- HP Borosilicate
 - Up to 600°F (316°C)
 - Higher Tolerances
- Aluminosilicate
 - Up to 800°F (426°C)

Glass Sizes – Industry Standard 34mm
 Sizes 1 thru 9 (All models except 300L)

Size	Length	Typical Visible Range
1	4-1/2" (115mm)	3-3/4" (95mm)
2	5-1/2" (140mm)	4-3/4" (121mm)
3	6-1/2" (165mm)	5-3/4" (146mm)
4	7-1/2" (190mm)	6-3/4" (171mm)
5	8-5/8" (220mm)	7-7/8" (200mm)
6	9-7/8" (250mm)	9-1/8" (232mm)
7	11" (280mm)	10-1/4" (260mm)
8	12-5/8" (320mm)	11-7/8" (302mm)
9	13-3/8" (340mm)	12-5/8" (321mm)



Glass Sizes – Jerguson 25mm
 Sizes 11 thru 20 (Series 300L - Obsolete 5 & 12)

Size	Length	Typical Visible Range
11	11" (280mm)	10-1/4" (260mm)
12	12" (305mm)	11-1/4" (286mm)
13	13" (330mm)	12-1/4" (311mm)
15	15" (381mm)	14-1/4" (362mm)
18	18" (457mm)	17-1/4" (438mm)
20	20" (508mm)	19-1/4" (489mm)

Specification

Materials of Construction

- Borosilicate Glass
- Gaskets
 - IFG® -5500 Standard (Seal/Cushion)
 - Graphite, with .002" (.05mm) stainless steel reinforcement layer
 - Teflon®
 - Other Materials Available

Chamber

- Carbon Steel
 - To -20°F (-28°C)
- Low Temp Carbon Steel
 - To -50°F (-45°C)
 - Charpy Impact Tested
 - B7M Bolts / 2HM Nuts
- Stainless Steel
 - To -325°F (-198°C)
 - Dual Rated 316/316L
- All Acceptable for NACE Service

Shields

Shields are used to protect the glass from chemical attack. Two shields are available: Mica and PCTFE.

Mica: Mica shields are used to protect the glass from corrosion in high pressure steam (over 300WSP) and caustic applications (pH >11).
 PCTFE: PCTFE shields (formerly known as Kel-F®) are primarily used in Hydrofluoric Acid service. Note that the PCTFE shield also serves as the sealing gasket; no additional sealing gasket is required.



Gage Code for Jerguson Gages

Special Features
 M = Mica Shield
 K = PCTFE (Kel-F) Shield
 F = Non-frosting
 H = External Heating
 E = Electrical Heating
 T = Internal Heating
 CH = Close Hook-up (Side or Back Conns.)
 W = Weld Pad
 IW = Isolable Weld Pad

Glass Size
 Series 300L:
 11, 12, 13,
 15, 18, 20

Other Series:
 1 thru 9

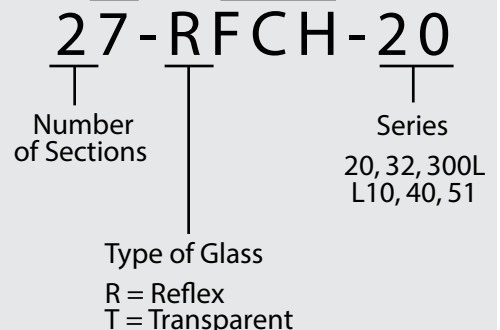

Gasket Materials— Standard Offering

Material	Min. Temperature	Max. Temperature	Rating Factor
Garlock IFG-5500	-40°F (-40°C)	550°F (288°C)	100%
25% Glass Filled TFE	-328°F (-200°C)	500°F (260°C)	100%
Grafoil	-400°F (-240°C)	800°F (427°C)	100%
PCTFE (Kel-F) Shield	-400°F (-240°C)	302°F (150°C)	50%

Authorised Distributor: **AMPMECH**
 46, Jalan SS 22/21, Damansara Jaya,
 47400 Petaling Jaya,
 Selangor Darul Ehsan, Malaysia.
 Email: ampmech@ampmech.com
 Website: www.ampmech.com