



Reflex  
**R-40**



Transparent  
**T-40**

# For Pressures Up To 5000 PSI @ 100 °F

## Series 40

### Features

- Recessed Gasket Seat in Chamber and Cover
- Tempered Borosilicate Glass conforming to BS3463, JIS B8211, & DIN 7081
- All parts listed in ASTM & ASME B31.3
- ABS Certified
- All Gages feature a continuous, one-piece chamber regardless of length

The Series 40 gage is used in high pressure process applications or process steam to 1500 PSI. Note that both reflex and transparent gages have plain (transparent) glass. A reflex gage may be difficult to read with a clear fluid as you will not see a silver/black contrast.

SERIES 40 GAGE RATING (PSI)

SERIES 40		
Temperature		CS & 316SS
°F	°C	
100	38	5000
200	93	4685
300	149	4370
400	204	4055
500	260	3740
600	316	3425
For temperatures above 600°F (316°C) Aluminosilicate Glass must be used		
700	371	3110
800	427	2795

Saturated Steam Rating 1500 WSP

SERIES 40 GAGE RATING (BarG)

SERIES 40		
Temperature		CS & 316SS
°F	°C	
100	38	344.7
200	93	323.0
300	149	301.3
400	204	279.6
500	260	257.9
600	316	236.1
For temperatures above 600°F (316°C) Aluminosilicate Glass must be used		
700	371	214.4
800	427	192.7

Saturated Steam Rating 1500 WSP

*TEST PRESSURE: All gages are hydrostatically tested by Jerguson prior to shipment @ 1 1/2 times the design pressure rating at 100°F (38°C).*

# Liquid Level Gages

## Series R-40 Reflex, Series T-40 Transparent

Sect. X Size	Visible Range		Overall Length (End Connected Gage Only)		Approximate Weight			
	in	mm	in	mm	Reflex, R-40		Transp., T-40	
					lbs.	Kgs	lbs.	Kgs
<b>SINGLE-SECTION GAGES</b>								
11	3.625	92	7.250	184	20	9.1	28	12.7
12	4.625	117	8.250	210	22	10.0	32	14.5
13	5.625	143	9.250	235	25	11.4	35	15.9
14	6.625	168	10.250	260	27	12.3	38	17.3
15	7.750	197	11.375	289	30	13.6	42	19.1
16	9.000	229	12.625	321	34	15.5	47	21.4
17	10.125	257	13.750	349	37	16.8	52	23.6
18	11.750	298	15.375	391	41	18.6	57	25.9
19	12.500	318	16.125	410	43	19.5	60	27.3
<b>TWO-SECTION GAGES</b>								
23	14.875	378	18.500	470	50	22.7	70	31.8
24	16.875	429	20.500	521	54	24.5	76	34.5
25	19.125	486	22.750	578	60	27.3	84	38.2
26	21.625	549	25.250	641	68	30.9	94	42.7
27	23.875	606	27.500	699	74	33.6	104	47.3
28	27.125	689	30.750	781	82	37.3	114	51.8
29	28.625	727	32.250	819	86	39.1	120	54.5
<b>THREE-SECTION GAGES</b>								
36	34.250	870	37.875	962	102	46.4	141	64.1
37	37.625	956	41.250	1048	111	50.5	156	70.9
38	42.500	1080	46.125	1172	123	55.9	171	77.7
39	44.750	1137	48.375	1229	129	58.6	180	81.8
47	51.375	1305	55.000	1397	148	67.3	208	94.5
48	57.875	1470	61.500	1562	164	74.5	228	103.6
49	60.875	1546	64.500	1638	172	78.2	240	109.1

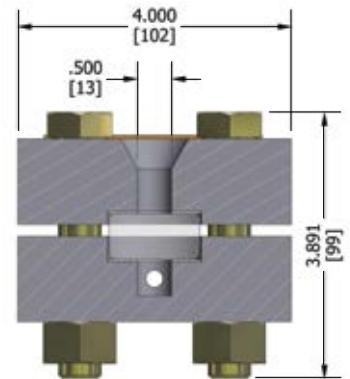

Series R-40 Reflex

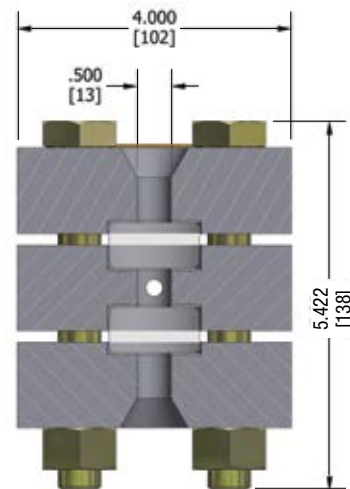

Series T-40 Transparent



CE models available

## Specifications (See page 3 for Specifying Information)

### LENGTHS

Gage sections are available in nine standard glass sizes. Longer sizes are constructed with multiple vision slots in a continuous solid bar chamber.

### CONNECTIONS

Standard connections are at top and bottom and are 1/2" or 3/4" NPT female. Optional connections are available, such as socket weld, flanged or close hook up (side/side).

### LIQUID CHAMBER

Machined from bar stock. The gasket seat is recessed to provide lateral support, and facilitate positioning of the gasket. This seat aids in field repair, and enhances safety/reliability.

### COVERS

Carbon steel non-shrouded covers are standard with optional materials available. The cushion gasket surface is recessed on all covers.

### BOLTS & NUTS

Steel fasteners, heat treated for strength; A193 B7 bolts / A194 2H nuts. NACE option for A193 B8M bolts / A194 8M nuts (316 Stainless Steel).

### GLASS

Tempered Borosilicate is used to 600°F (316°C). Aluminosilicate is used to 800°F (427°C). Transparent glass may be protected from corrosive media with mica or Neoflon PCTFE shields.

### GASKETS

Standard gaskets are precision die cut in proprietary Jerguson® dies.

### FINISH

All carbon steel parts are finish coated prior to assembly with Jerguson Protective FP-16. Optional coatings such as FP-11 offshore available.

### VALVES

Use of Jerguson gage valves is strongly recommended. Standard features include safety ballchecks which help prevent loss of product and physical injury in the event of a catastrophic failure.

# Glass Types & Sizes

## Glass Materials

- Borosilicate
  - Up to 600°F (316°C)
  - Up to 300 WSP
  - Over 300 WSP, Mica Protected Transparent Glass Only
- HP Borosilicate
  - Up to 600°F (316°C)
  - Higher Tolerances
- Aluminosilicate
  - Up to 800°F (426°C)

Glass Sizes – Industry Standard 34mm  
 Sizes 1 thru 9 (All models except 300L)

Size	Length	Typical Visible Range
1	4-1/2" (115mm)	3-3/4" (95mm)
2	5-1/2" (140mm)	4-3/4" (121mm)
3	6-1/2" (165mm)	5-3/4" (146mm)
4	7-1/2" (190mm)	6-3/4" (171mm)
5	8-5/8" (220mm)	7-7/8" (200mm)
6	9-7/8" (250mm)	9-1/8" (232mm)
7	11" (280mm)	10-1/4" (260mm)
8	12-5/8" (320mm)	11-7/8" (302mm)
9	13-3/8" (340mm)	12-5/8" (321mm)



Glass Sizes – Jerguson 25mm  
 Sizes 11 thru 20 (Series 300L - Obsolete 5 & 12)

Size	Length	Typical Visible Range
11	11" (280mm)	10-1/4" (260mm)
12	12" (305mm)	11-1/4" (286mm)
13	13" (330mm)	12-1/4" (311mm)
15	15" (381mm)	14-1/4" (362mm)
18	18" (457mm)	17-1/4" (438mm)
20	20" (508mm)	19-1/4" (489mm)

# Specification

## Materials of Construction

- Borosilicate Glass
- Gaskets
  - IFG® -5500 Standard (Seal/Cushion)
  - Graphite, with .002" (.05mm) stainless steel reinforcement layer
  - Teflon®
  - Other Materials Available

## Chamber

- Carbon Steel
  - To -20°F (-28°C)
- Low Temp Carbon Steel
  - To -50°F (-45°C)
  - Charpy Impact Tested
  - B7M Bolts / 2HM Nuts
- Stainless Steel
  - To -325°F (-198°C)
  - Dual Rated 316/316L
- All Acceptable for NACE Service

## Shields

Shields are used to protect the glass from chemical attack. Two shields are available: Mica and PCTFE.

Mica: Mica shields are used to protect the glass from corrosion in high pressure steam (over 300WSP) and caustic applications (pH >11). PCTFE: PCTFE shields (formerly known as Kel-F®) are primarily used in Hydrofluoric Acid service. Note that the PCTFE shield also serves as the sealing gasket; no additional sealing gasket is required.



## Gage Code for Jerguson Gages

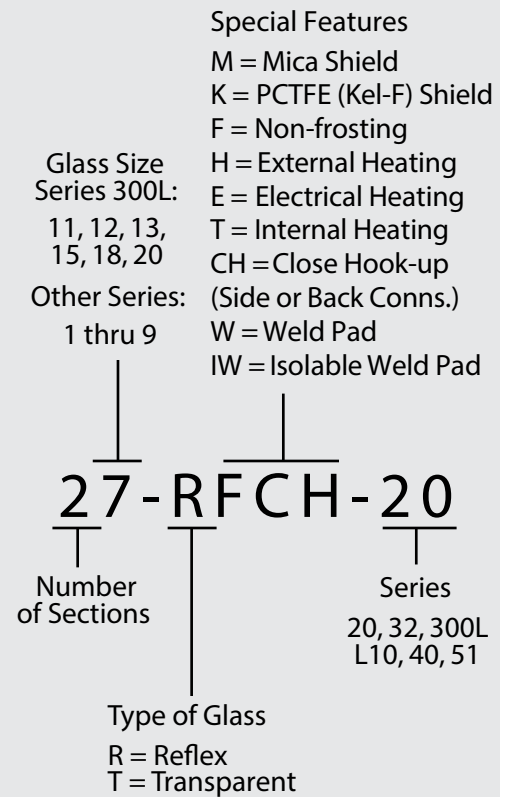

## Gasket Materials— Standard Offering

Material	Min. Temperature	Max. Temperature	Rating Factor
Garlock IFG-5500	-40°F (-40°C)	550°F (288°C)	100%
25% Glass Filled TFE	-328°F (-200°C)	500°F (260°C)	100%
Grafoil	-400°F (-240°C)	800°F (427°C)	100%
PCTFE (Kel-F) Shield	-400°F (-240°C)	302°F (150°C)	50%

Authorised Distributor: **AMPMECH**

46, Jalan SS 22/21, Damansara Jaya, 47400 Petaling Jaya, Selangor Darul Ehsan, Malaysia.  
 Email: [ampmech@ampmech.com](mailto:ampmech@ampmech.com)  
 Website: [www.ampmech.com](http://www.ampmech.com)