



Transparent  
**T-51**

# For Pressures Up To 10,000 PSI @ 100°F

## Series 51

### Features

- Tempered Borosilicate Glass conforming to BS3463, JIS B8211, & DIN 7081
- Available Transparent Only
- Ported Gage with O-Ring Seals
- All gages feature a continuous, one-piece chamber regardless of length

The Jerguson Series 51 Liquid Level Gage is a specially designed instrument capable of withstanding high pressures. The one-piece chamber is machined out of solid bar stock carbon steel or stainless steel as specified. It is drilled lengthwise and crosswise at each port leaving tie-bars in between to resist deflection under pressure. Viton® O-Rings that seal each port are unaffected by most liquids that cause deterioration in rubber. The O-Rings are seated in recessed circular channels to assure proper sealing action.

Pressure/Temperature Ratings for  
NPT Connections, PSI (BarG)

CARBON & STAINLESS STEEL			
Temperature		PSI	BarG
°F	°C		
100	38	6000	413.7
200	93	6000	413.7
300	149	6000	413.7
400	204	6000	413.7

*Not recommended for steam service.*

Pressure/Temperature Ratings  
for Socket Weld or High Pressure  
Connections, PSI (BarG)

CARBON & STAINLESS STEEL			
Temperature		PSI	BarG
°F	°C		
100	38	10000	689.5
200	93	10000	689.5
300	149	10000	689.5
400	204	10000	689.5

*Not recommended for steam service.*

# Liquid Level Gages

## Series 51

Sect. X Size	Visible Range		Overall Length (End Connected Gage Only)		Approximate Weight		No. of Ports
	in	mm	in	mm	lbs.	Kgs	
<b>SINGLE-SECTION GAGES</b>							
11	3.625	92	6.500	165	31	14.0	5
12	4.437	113	7.500	191	35	16.0	6
13	5.250	133	8.500	216	39	17.5	7
14	6.062	154	9.500	241	42	19.0	8
15	7.687	195	10.625	270	46	21.0	10
16	8.500	216	11.875	302	52	23.5	11
17	10.125	257	13.000	330	57	26.0	13
18	11.750	298	14.625	371	63	28.5	15
19	12.562	319	15.375	391	66	30.0	16
<b>TWO-SECTION GAGES</b>							
23	12.500	318	15.750	400	77	35.0	14
24	14.312	364	17.750	451	84	38.0	16
25	16.656	423	20.000	508	92	42.0	20
26	19.125	486	22.500	572	103	47.0	22
27	21.875	556	24.750	629	114	52.0	26
28	25.125	638	28.000	711	125	57.0	30
29	26.719	679	29.500	749	132	60.0	32
<b>THREE-SECTION GAGES</b>							
36	29.750	756	33.125	841	155	70.5	33
37	33.625	854	36.500	927	172	78.0	39
38	38.500	978	41.375	1051	188	85.5	45
39	40.875	1038	43.625	1108	198	90.0	48
<b>FOUR-SECTION GAGES</b>							
47	45.375	1153	48.250	1226	229	104.0	52
48	51.875	1318	54.750	1391	151	114.0	60
49	55.031	1398	57.750	1467	264	120.0	64

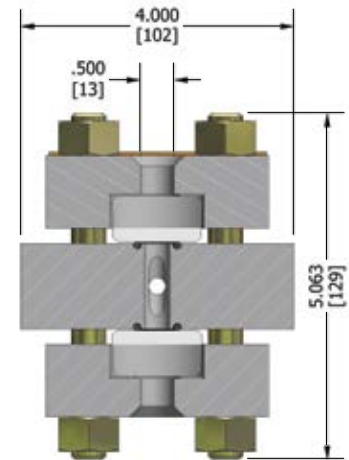

Series 51



CE models available



- NOTES: 1. Standard hydrotest pressure is 1.5 times the gage glass rated pressure, up to 10,000 PSI.  
 2. When ordering, state maximum working pressure – temperature.  
 3. When ordering spare or replacement glass, specify "H.P." and gage size.

## Specifications (See page 3 for Specifying Information)

### MAXIMUM VISIBILITY

This gage is unique in that it combines the strength to withstand very high pressures with a good degree of visibility. Port holes in the chamber are drilled on an angle for positive drainage of the port, thus preventing false level reading caused by liquid hang up.

### RATINGS

Carbon steel and 316SS are rated for 6,000 PSI @ 400°F using Viton® O-Rings when NPT end-connections are specified.

Carbon steel and 316SS are rated for 10,000 PSI @ 400°F using Viton® O-Rings when socket weld or high pressure fittings are utilized.

### CONNECTIONS

1/2" N.P.T. or Flanged to 6,000 PSI. High pressure fittings recommended for pressures over 6,000 PSI.

### CHOICE OF LENGTHS

Series 51 Gages are offered in standard sizes up to 6 feet in length. They are built to order in greater lengths.

### CONSTRUCTION

Chambers are machined from solid bar stock steel, carbon or stainless as specified. Covers are carbon steel. Studs are threaded through the chamber to allow glasses on each side to be changed individually.

Although the tempered longitudinal glass is carefully chosen for "close tolerance," the design of the chamber and individual self-sealing O-Rings at each port confine the pressure on the glass to 1/2" circles. Fibrous cushions are used between covers and glasses.

# Glass Types & Sizes

## Glass Materials

- Borosilicate
  - Up to 600°F (316°C)
  - Up to 300 WSP
  - Over 300 WSP, Mica Protected Transparent Glass Only
- HP Borosilicate
  - Up to 600°F (316°C)
  - Higher Tolerances
- Aluminosilicate
  - Up to 800°F (426°C)

Glass Sizes – Industry Standard 34mm  
 Sizes 1 thru 9 (All models except 300L)

Size	Length	Typical Visible Range
1	4-1/2" (115mm)	3-3/4" (95mm)
2	5-1/2" (140mm)	4-3/4" (121mm)
3	6-1/2" (165mm)	5-3/4" (146mm)
4	7-1/2" (190mm)	6-3/4" (171mm)
5	8-5/8" (220mm)	7-7/8" (200mm)
6	9-7/8" (250mm)	9-1/8" (232mm)
7	11" (280mm)	10-1/4" (260mm)
8	12-5/8" (320mm)	11-7/8" (302mm)
9	13-3/8" (340mm)	12-5/8" (321mm)



Glass Sizes – Jerguson 25mm  
 Sizes 11 thru 20 (Series 300L - Obsolete 5 & 12)

Size	Length	Typical Visible Range
11	11" (280mm)	10-1/4" (260mm)
12	12" (305mm)	11-1/4" (286mm)
13	13" (330mm)	12-1/4" (311mm)
15	15" (381mm)	14-1/4" (362mm)
18	18" (457mm)	17-1/4" (438mm)
20	20" (508mm)	19-1/4" (489mm)

# Specification

## Materials of Construction

- Borosilicate Glass
- Gaskets
  - IFG® -5500 Standard (Seal/Cushion)
  - Graphite, with .002" (.05mm) stainless steel reinforcement layer
  - Teflon®
  - Other Materials Available

## Chamber

- Carbon Steel
  - To -20°F (-28°C)
- Low Temp Carbon Steel
  - To -50°F (-45°C)
  - Charpy Impact Tested
  - B7M Bolts / 2HM Nuts
- Stainless Steel
  - To -325°F (-198°C)
  - Dual Rated 316/316L
- All Acceptable for NACE Service

## Shields

Shields are used to protect the glass from chemical attack. Two shields are available: Mica and PCTFE.

Mica: Mica shields are used to protect the glass from corrosion in high pressure steam (over 300WSP) and caustic applications (pH >11).  
 PCTFE: PCTFE shields (formerly known as Kel-F®) are primarily used in Hydrofluoric Acid service. Note that the PCTFE shield also serves as the sealing gasket; no additional sealing gasket is required.



## Gage Code for Jerguson Gages

Special Features  
 M = Mica Shield  
 K = PCTFE (Kel-F) Shield  
 F = Non-frosting  
 H = External Heating  
 E = Electrical Heating  
 T = Internal Heating  
 CH = Close Hook-up (Side or Back Conns.)  
 W = Weld Pad  
 IW = Isolable Weld Pad

Glass Size  
 Series 300L:  
 11, 12, 13,  
 15, 18, 20

Other Series:  
 1 thru 9

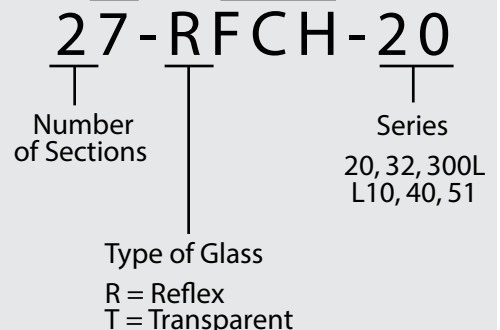

## Gasket Materials— Standard Offering

Material	Min. Temperature	Max. Temperature	Rating Factor
Garlock IFG-5500	-40°F (-40°C)	550°F (288°C)	100%
25% Glass Filled TFE	-328°F (-200°C)	500°F (260°C)	100%
Grafoil	-400°F (-240°C)	800°F (427°C)	100%
PCTFE (Kel-F) Shield	-400°F (-240°C)	302°F (150°C)	50%

Authorised Distributor: **AMPMECH**  
 46, Jalan SS 22/21, Damansara Jaya,  
 47400 Petaling Jaya,  
 Selangor Darul Ehsan, Malaysia.  
 Email: [ampmech@ampmech.com](mailto:ampmech@ampmech.com)  
 Website: [www.ampmech.com](http://www.ampmech.com)