

# Jerguson's Tri-Magnet Level Switches Deliver Unparalleled Reliability

The innovative use of repelling magnetic fields eliminates mechanical elements that are prone to failure in high temperatures, extreme vibration, or simply fatigue over time.

## FEATURES

- Tri-Magnet Switching for Failure-Free Performance
- Vibration Resistant
- Pump Control
- 316 Stainless Steel Trim
- Multi-Point Alarm



(Series JD)



(SureTest™ (STS) option)

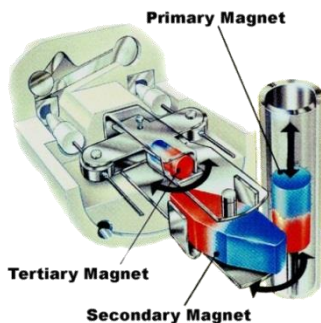

**Unique 3 magnet latching.  
No springs...No problem.**

*"The new switches are very rugged and dependable, and most importantly, they are mercury-free and safe for the environment. Dealing with spilled mercury is an extremely difficult task, but it is one we don't have to worry about with these new switches. The Jerguson Tri-Magnet Level Switches have been in operation in our facility since May 2007."*

*-Maintenance Superintendent,  
Major Utility Power Generation Plant*

The Tri-Magnet Level Switch was endurance tested to over 850,000 cycles without failure.



# JERGUSON® LEVEL SWITCHES THE SWITCH MECHANISM

## Principle of Operation: Switch Mechanism

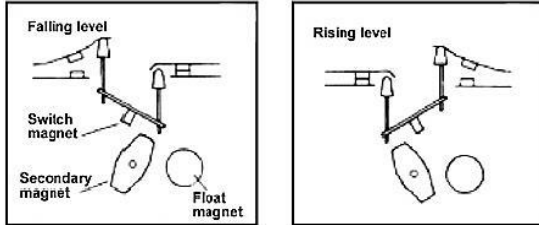
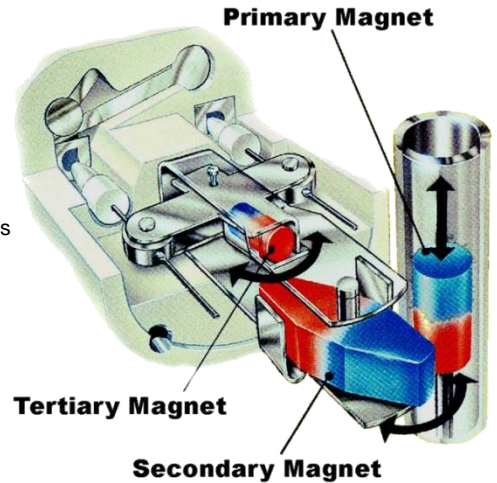
The switch mechanism is based on a unique three-dimensional magnet design where the snap action is accomplished by the utilization of magnetic repulsion and attraction. The primary magnet mounted on the float rod causes the secondary magnet to rotate as it passes up and down. The switch magnet is repelled by the secondary and snaps to the opposite side. This causes the cradle to pivot, moving the push rods, which operate the switch contacts. The result is positive snap action interlock switching...no springs...no spring problems!

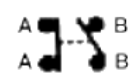

Schematic showing three-magnet system

Type	Choice of Switch Mechanisms Application	4 Contact Type X4, D4, H4, P4, E4
X4, X8	<b>General purpose</b> - 10 amp mechanisms for general purpose duties up to 480°F	2 x S.P.S.T AA Make on Rise BB Make on Fall 
D4, D8	<b>High temperature</b> - 5 amp mechanisms for high temperature applications up to 750°F	<a href="#">Link for SPDT/SPCO</a>
H4, H8	<b>Hermetically sealed</b> - 5 amp mechanisms suitable for temperatures up to 480°F, contaminated atmosphere environments and intrinsically safe circuits. All moving parts and contacts enclosed in an inert gas filled stainless steel enclosure.	<b>8 Contact Type X8, D8, H8, P8, E8</b>
P4, P8	<b>Low current</b> - 0.25 amp gold-plated contact switch mechanism for use in intrinsically safe or low power circuits up to 750°F	D.P.D.T. 4 x S.P.S.T. AA Make on Rise BB Make on Fall 
E4, E8	<b>Encapsulated</b> - 5 amp switch mechanism is sealed / encapsulated inside aluminum housing, suitable for temperatures to 850°F	<a href="#">Link for DPDT/DPCO</a>

Note: Max temperature of top mount displacer operated level switch = 400°F

## Principle of Operation: Displacer & Spring

The displacer element is suspended from a spring by a stainless steel cable. The weight of the displacer keeps tension on the spring at all times, causing the spring to extend. Attached to the spring is the rod and magnet assembly, which is free to move up and down within the pressure tube as the spring contracts or extends, actuating the switch mechanism.

A rising liquid submerges the displacer, creating a buoyant force that carries some displacer weight for the spring. With less weight on the spring it contracts, raising the magnet, actuating the switch mechanism. On a falling liquid level the displacer element is uncovered, reducing the buoyant force and transferring the weight back to the spring. The spring extends under the weight, lowering the magnet, re-setting the switch mechanism.

This simple principle can be refined to operate a single switch over a very wide differential by providing the buoyancy force from two displacer elements instead of a single one.

Two switch models are available for applications with narrow differentials for pump control or with appropriate wide differentials.

In all cases, because the element(s) are suspended on a cable, switching or control levels may be many feet below the mounting flange, and are fully field adjustable to re-setting the displacer element(s) on the cable.

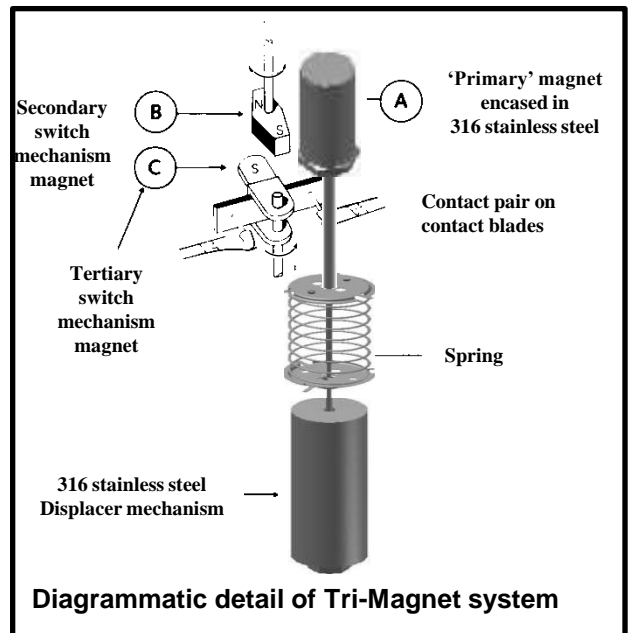

Diagrammatic detail of Tri-Magnet system

## Principle of Operation: SureTest™ Option

The SureTest™ is a local, manual check feature. It allows the operator to simulate a high level in order to check the operation of the switch, without breaking the pressure boundary. By extending the pressure tube, and raising the position of the switch enclosure, the SureTest™ housing can be installed between the switch enclosure and the chamber/tank.

Within the SureTest™ housing is a high-strength, rare earth magnet, that surrounds and moves along the outside of the pressure tube. Inside the pressure tube, connected to the primary magnet within the switch enclosure (responsible for actuating the switch mechanism), there is another high-strength, rare earth magnet, that moves with the level. By pulling down on the handle, the arm within the housing pivots up. Directly attached to the end of the arm is the magnet external to the pressure tube, getting pulled up with the arm. When the external magnet comes in proximity to the internal magnet they couple and start to move up together. Since the internal magnet is tied to the primary magnet, the entire assembly gets lifted up as it would with a rising fluid level. This motion causes the primary switch magnet to pass and actuate the secondary switch magnet (see 'Principle of Operation: Switch Mechanism' section). Releasing the handle allows the springs within the SureTest™ housing to reverse the motion, resetting the switch and returning the unit to its original position.

- Options:
- Bent Handle, for use with pulley system (pulley/cable not included) – Design Option “STB”
  - (See model code) - Straight Handle (as shown below) – Design Option “STS”
  - Locking Device, prevents the manual check feature from unintentional operation - Design Option “LD”

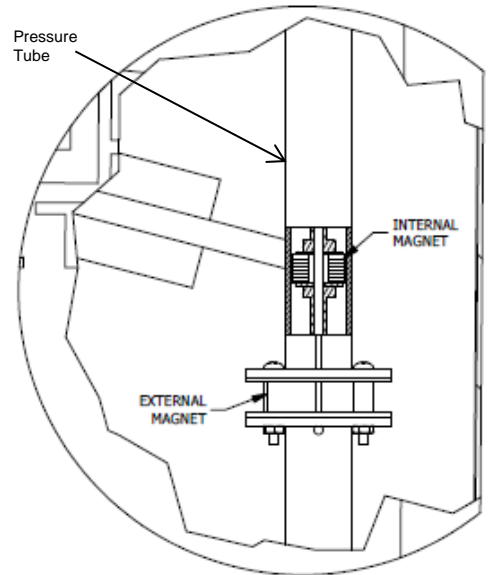
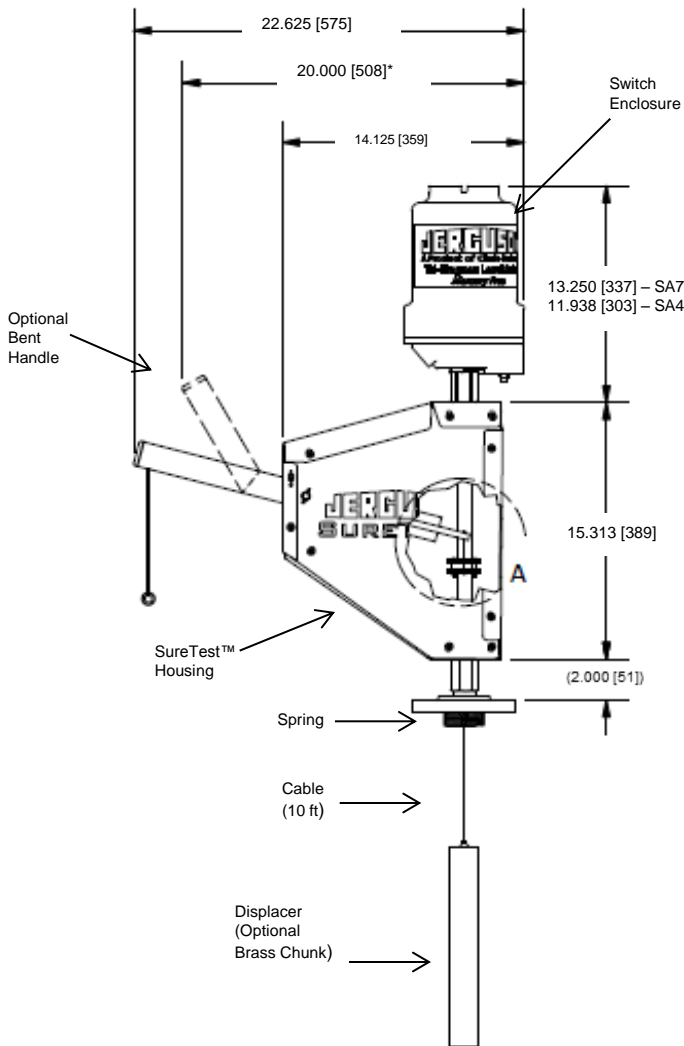

Note: Dimensions in inches w/ mm in brackets.  
\*Also available with bent handle option

## Principle of Operation: Brass Displacer or Chunk Options

Both options are designed for floating roof systems; open storage containers with a roof that floats on top of the liquid. The brass element (displacer or chunk) is suspended by a brass ball chain below the standard spring. The element weight pulls on the ball chain, extends the spring, & sets the switch in a low state. A rising liquid lifts the roof, contacting the element. With the element resting on the roof, and its weight transferred off of the spring, the spring contracts & trips the switch to a high state. Since brass is non-sparking, contact between the element and roof will not ignite any vapors, if present.

The brass displacer is also designed to operate directly in the liquid, identical to its standard (316SS) counterpart. If the liquid seal on the floating roof were to unexpectedly fail, allowing fluid to cover the roof, this option would continue to provide reliable operation and detect the liquid. (Reference API 2350 for point switch requirements on floating roof tanks.)

In all cases, because the element(s) are suspended on a cable, switching or control levels may be many feet below the mounting flange, and are fully field adjustable to re-setting the displacer element(s) on the cable.

- Options:
- Brass Chunk, for use on floating roof tanks (rising roof lifts chunk, activates switch) - Design Option "BC"
  - (See model code) - Brass Displacer, for use with either floating roof tanks or liquid - Design Option "BD"

\*Note: Both brass options are available either stand alone, or in conjunction with the SureTest.

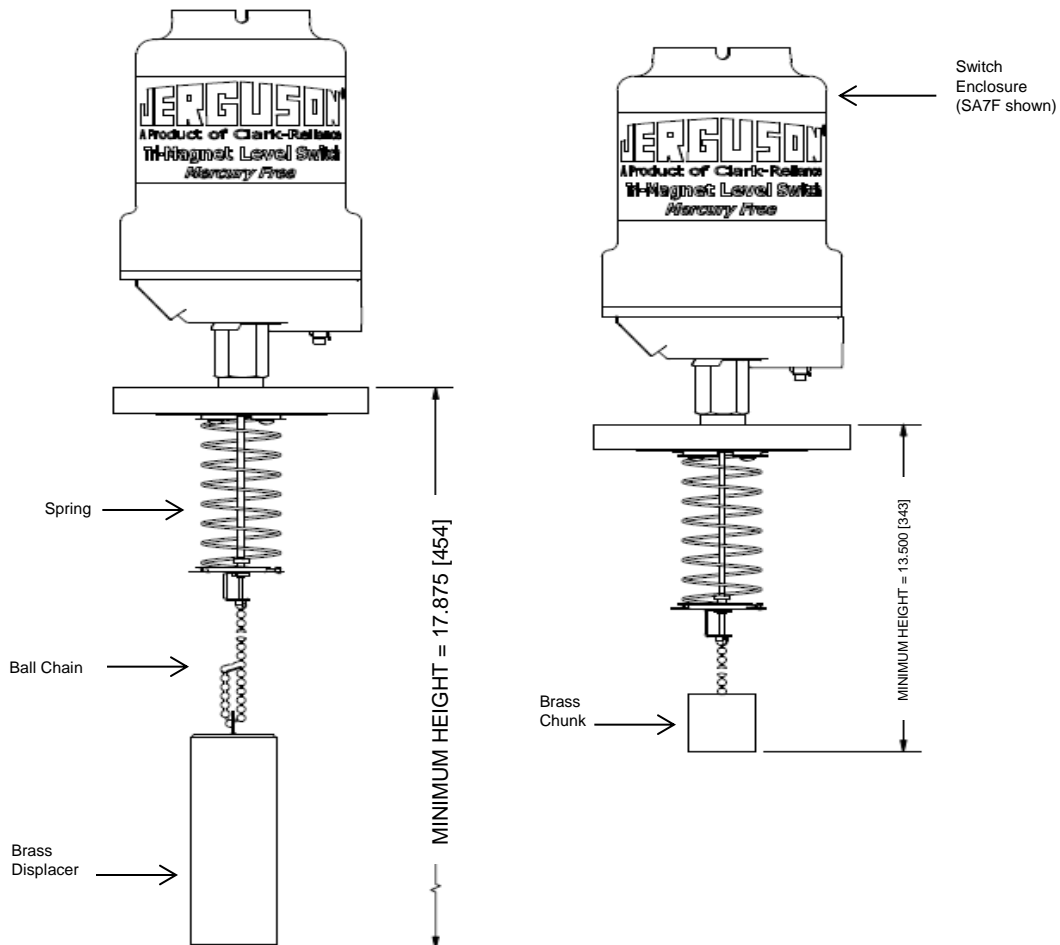

# ORDERING INFORMATION

## TYPICAL MODEL

**JDC 2D SA4 1 X4 D71** \_\_\_\_\_

### MATERIAL OF CONSTRUCTION

CODE	Chamber Material	Trim
JDC	Carbon Steel	316 Stainless Steel
JDS	316 Stainless Steel	316 Stainless Steel

### INTERNAL MOUNT DISPLACER TYPES

CODE	Function-Differential	Displacer	SPDT	DPDT	Tolerance	Press. Rating (@ 100 F) <sup>1</sup>
1D	Single Switch-Narrow	316-SST	.50 - 1.2	.50 - 1.2	N/A	1000 PSIG
2D	Single Switch-Wide	316-SST	.50 - 1.5	.50 - 1.5	±10%	1000 PSIG
3D	Dual Switch-Wide	316-SST	.60 - 1.2	.80 - 1.2	±5%	1000 PSIG
8D	Dual Switch-Narrow	316-SST	.60 - 1.2	.80 - 1.2	±10%	1000 PSIG

### ENCLOSURE TYPES

CODE	Duty	Material of Cover	Material of Base	Material of Tubing	Material of Threaded Adaptor	Maximum Number of Switches
SA4N	Weather-Proof	Aluminum Alloy		316 Stainless Steel	To match chamber material	1-2
S17F	Explosion-Proof Factory Mutual Cl. I, Div. 1, Grps B, C & D	Cast Iron				
SA7F		Drawn Steel	Aluminum Alloy			

### NUMBER OF SWITCH MECHANISMS

**Specify No. of Switches Required**

No. of Switches

Design Options	
(Omitted)	Standard Design
BD	Brass Displacer <sup>23</sup>
BC	Brass Chunk <sup>45</sup>
STS	SureTest™ Feature, Straight Handle <sup>6</sup>
STB	SureTest™ Feature, Bent Handle <sup>6</sup>
LD	SureTest™ Locking Device <sup>8</sup>
X	Special Design

### MOUNTING CONNECTION

CODE	SIZE	CARBON STEEL RATING	SST RATING
D71	3" 150# R.F. ASME	285 PSIG @ 100°F	275 PSIG @ 100°F
D73	3" 300# R.F. ASME	740 PSIG @ 100°F	720 PSIG @ 100°F
D76	3" 600# R.F. ASME	1480 PSIG @ 100°F	1400 PSIG @ 100°F
D91	4" 150# R.F. ASME	285 PSIG @ 100°F	275 PSIG @ 100°F
D93	4" 300# R.F. ASME	740 PSIG @ 100°F	720 PSIG @ 100°F
D96	4" 600# R.F. ASME	1480 PSIG @ 100°F	1400 PSIG @ 100°F
DB1	6" 150# R.F. ASME	285 PSIG @ 100°F	275 PSIG @ 100°F
D6M	2 1/2" MNPT	1000 PSIG @ 100°F	1000 PSIG @ 100°F
D7M	3" MNPT	1000 PSIG @ 100°F	1000 PSIG @ 100°F

### SWITCH MECHANISM TYPES

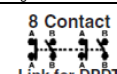
	Temp Wet-side °F <sup>7</sup>	AC max. values			DC Max. values			
		VA	Volts	Amps	Watts	Volts	Res. Amps	Ind. Amps
<b>X4</b> <b>D4</b> <b>H4</b> <b>E4</b> <b>P4</b>  Link for SPDT Two independent single pole single throw contact sets	480	2000	440	10	50	250	10	0.5
	750	2000	440	5	50	250	5	0.5
	480	2000	440	5	50	250	5	0.5
	850	2000	440	5	50	250	5	0.5
<b>X8</b> <b>D8</b> <b>H8</b> <b>E8</b> <b>P8</b>  Link for DPDT Four independent single pole single throw contact sets	480	2000	440	10	50	250	10	0.5
	750	2000	440	5	50	250	5	0.5
	480	2000	440	5	50	250	5	0.5
	850	2000	440	5	50	250	5	0.5
	750	6	250	0.25	3.6	250	0.25	0.1

### Notes

- Overall pressure rating of unit is the lowest of displacer rating, process connection rating, and rating of any options (if applicable).
- Rated to 900PSIG @ 100°F
- CF for 2D,3D,8D
- Rating N/A for solid chunk
- CF for 2D,3D
- Only available for single switch units (1D,2D)
- Due to spring, max temperature of top mount displacer operated level switch = 400°F
- Only available with STS and STB Design Options

# DIMENSIONAL AND OPERATING LEVEL DATA

Single Switch, Narrow Differential	Single Switch, Wide Differential	Dual Switch, Narrow Differential	Dual Switch, Wide Differential
1D SST: A = 7 1/2 D = 2 1/2	2D SST: A = 7 1/2 D = 2 1/2	8D SST: A = 7 1/2 D = 2 1/2	3D SST: A = 7 1/2 B = 4 D = 2 1/2
S.G. 0.50 0.60 0.80 1.00	S.G. 0.50 0.60 0.80 1.00	S.G. 0.80 0.90 1.00 1.10	S.G. 0.80 0.90 1.00 1.10
E min. 3 1/2" 3" 2 1/2" 2"	E min. 7 1/4" 6 1/4" 5 1/4" 4 5/8"	E min. 2 1/2" 2 1/4" 2" 1 7/8"	E min. 5" 4 3/4" 4 1/2" 4 1/4"
<p>Specify for alarm duty, hi level or lo level.</p> <p>Switching level can be changed by simply moving the displacer up or down the cable.</p> <p>SST CABLE 10 FT. LONG</p>	<p>The two displacer elements are positioned at any point on the cable to correspond to the switching levels required. When the liquid level drops to the lower displacer, a switch is actuated and starts (or stops) a pump when the liquid rises to the upper displacer, the switch is again actuated to stop (or start) the pump.</p>	<p>The displacers are positioned to form two elements of similar lengths, such that two alarm points may be given. This arrangement is typical of sump application.</p>	<p>A pump is controlled between the middle and the lower displacers positioned on the cable at the required levels. Should the level rise to the upper displacer, this actuates the upper ala switch which remains actuated until the level drops to the middle displacer.</p> <p>Alternatively the upper switch could control a second pump.</p>

E min. = Differential

## ENCLOSURE DIMENSIONAL DATA

Type	Duty	Height G	Conduit Thread	Switch Adjustment	Weatherproof Rating
SA7, SI7	Explosion-proof	13 1/4"	1" NPT	3 3/8"	NEMA 4 & 7
SA4	Weather-proof	12"	1" NPT	3 3/8"	NEMA 4

## MATERIALS OF CONSTRUCTION

<b>Technical Specifications</b>	Designed in accordance with the requirements of B31.1 & B31.3. Pressure tested to 1.5 x maximum working pressures.	
Materials of Construction	Carbon Steel Mounting Flange	Stainless Steel Mounting Flange
Flanges/Fittings	ASTM A105	ASTM A182F316
Displacer & Trim	316 SS	316 SS
Spring	Inconel 600	Inconel 600

### Options:

- Low temperature carbon steel chambers
- Controls to meet NACE requirements
- A comprehensive NDT package

## JERGUSON® "FIT & FORGET" PRODUCTS PROVIDE THE SOLUTION TO YOUR LIQUID LEVEL CONTROL PROBLEMS

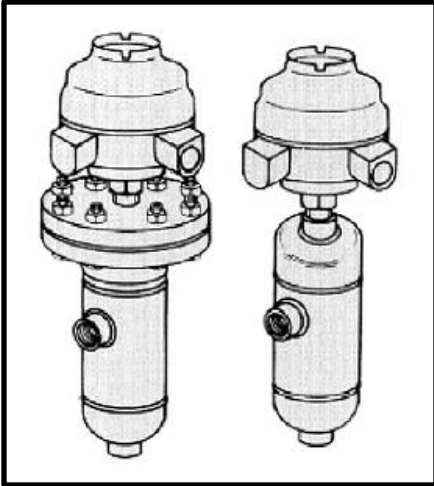

Medium Pressures  
ASME Class 150, 300, 600  
SG 0.40

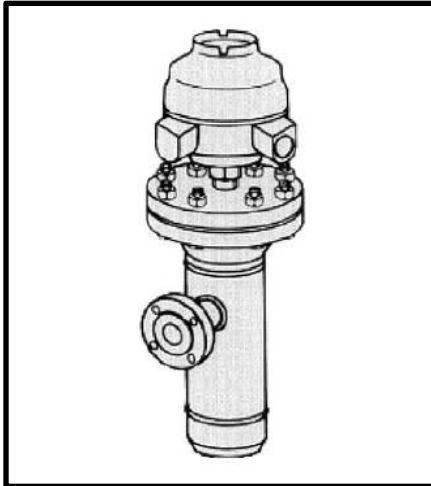

High Pressure  
ASME Class 900, 1500, 2500  
SG 0.40

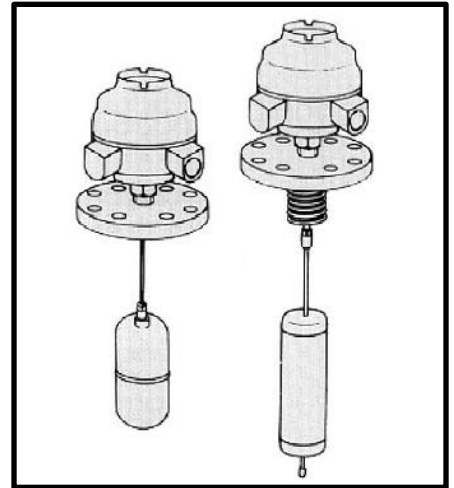

Direct Mounting  
ASME Class 150, 300, 600  
SG 0.40

### You can rely on us

The Jerguson range of liquid level controls is designed for operation in a wide variety of applications.

#### Typical Applications

Separators	Water Sumps
Compressors	Scrubbers
Knock Out Pots	Fractioning Columns
Condensers	Process Vessels
De-actuators	Condensate Tanks
Storage Tanks	Drainpots
Service Tanks	Accumulators
Header Tanks	Flush Vessels
Effluent Sumps & Tanks	Fuel Tanks
Heat Exchanger	Feedwater Heaters
Lube Oil Tanks	Surge Drums

Jerguson level switches are used for the control of liquids by companies all over the world.

Shell	Bechtel
Exxon	Bellili
Amoco	Ontario Hydro
Fluor	Nissaci-Sangyo
Hyundai	Foster Wheeler
Hitachi	Siemens
British Petroleum	Mannesmann-Demag
Mobil	Catalytic
Texaco	Techni
Ingersoll Rand	Technipetrol
Compare	Nuovo Pignone
Honeywell	Dresser

**5 YEAR  
MECHANICAL  
WARRANTY**

### OUR WARRANTY

All mechanical level devices are warranted free of defects in materials and workmanship for five years from the date of original factory shipment.

If returned within the stated warranty period, and upon factory inspection the cause of the claim is determined to be covered under the warranty, at option, the device will be repaired or replaced without cost to the purchaser (or owner), other than transportation.

Jerguson® shall not be liable for mis-application, labor claims, direct or consequential damage or expense arising from the installation or use of the equipment. There are no other warranties expressed or implied.

# Clark·Reliance®

## Instrumentation & Controls

**JERGUSON®**



Level Gages  
Magnetic Level Indicators  
Switches & Transmitters

**JACOBY·TARBOX®**



Sight Flow Indicators  
Sight Windows  
Eductors & Tank Agitators

**Reliance®**



Boiler Level Gages  
Remote Level Indicators  
Boiler Safety Instruments

## Filtration & Purification

**ANDERSON®**  
Separator



Gas Coalescing & Filtration  
Steam Separators & Traps  
Liquid Particle Filtration

**Enervac™**  
INTERNATIONAL ULC



Transformer Oil Purification  
SF6 Purification Equipment  
Air Dryers

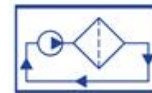

**OIL  
FILTRATION  
SYSTEMS®**



Vacuum Dehydrators  
Varnish Removal Systems  
Hi & Low Flow Filter Skids

## Elements, Internals, Parts & More



[www.clark-reliance.com](http://www.clark-reliance.com) / [www.clark-reliance.com/parts](http://www.clark-reliance.com/parts)

Authorised Distributor:



46, Jalan SS 22/21, Damansara Jaya,  
47400 Petaling Jaya,  
Selangor Darul Ehsan, Malaysia.

Email: [ampmech@ampmech.com](mailto:ampmech@ampmech.com)  
Website: [www.ampmech.com](http://www.ampmech.com)