

Jerguson's Tri-Magnet Level Switches deliver failure-free performance.

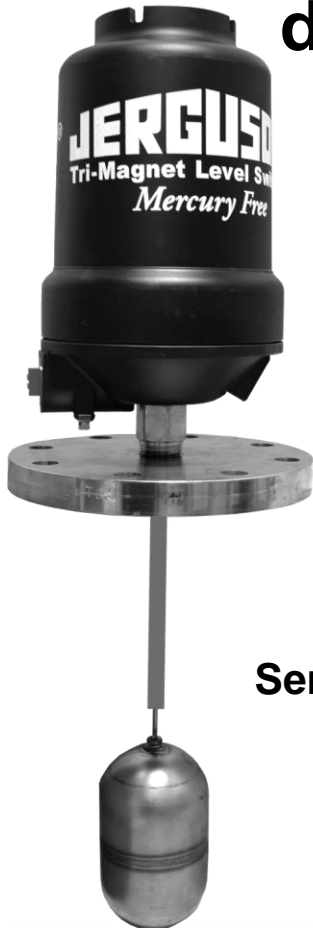

Series JD__F

The innovative use of repelling magnetic fields eliminates mechanical elements that are prone to failure in high temperatures, extreme vibration, or simply fatigue over time.

FEATURES

- Tri-Magnet Switching for Unparalleled Reliability
- Vibration Resistant
- 316 Stainless Steel Trim
- Multi-Point Alarm

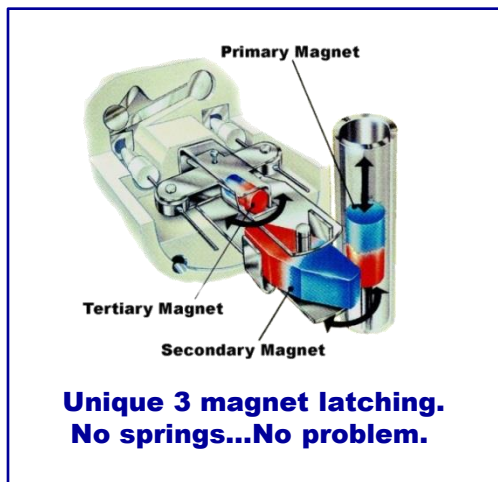

"The new switches are very rugged and dependable, and most importantly, they are mercury-free and safe for the environment. Dealing with spilled mercury is an extremely difficult task, but it is one we don't have to worry about with these new switches. The Jerguson Tri-Magnet Level Switches have been in operation in our facility since May 2007."

*-Maintenance Superintendent,
Major Utility Power Generation Plant*

The Tri-Magnet Level Switch was endurance tested to over 850,000 cycles without failure.

JERGUSON® LEVEL SWITCHES



THE SWITCH MECHANISM

Principle of Operation: Switch Mechanism

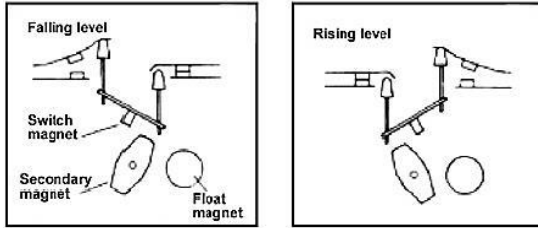
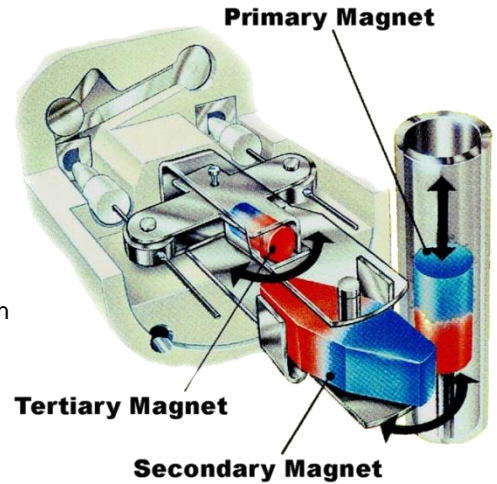
The switch mechanism is based on a unique three-dimensional magnet design where the snap action is accomplished by the utilization of magnetic repulsion and attraction. The primary magnet mounted on the float road causes the secondary magnet to rotate as it passes up and down. The switch magnet is repelled by the secondary and snaps to the opposite side. This causes the cradle to pivot, moving the push rods, which operate the switch contacts. The result is positive snap action interlock switching...**no springs...no spring problems!**

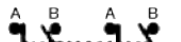
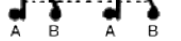

Schematic showing three-magnet system

Type	Choice of Switch Mechanisms	Application
X4, X8	General purpose - 10 amp mechanisms for general purpose duties up to 480°F	
D4, D8	High temperature - 5 amp mechanisms for high temperature applications up to 750°F	
H4, H8	Hermetically sealed - 5 amp mechanisms suitable for temperatures up to 480°F, contaminated atmosphere environments and intrinsically safe circuits. All moving parts and contacts enclosed in an inert gas filled stainless steel enclosure.	
P4, P8	Low current - 0.25 amp gold-plated contact switch mechanism for use in intrinsically safe or low power circuits up to 750°F	
E4, E8	Encapsulated - 5 amp switch mechanism is sealed / encapsulated inside aluminum housing, suitable for temperatures to 850°F	
		4 Contact Type D4, X4, P4, H4, E4 2 x S.P.S.T AA Make on Rise  B BB Make on Fall  B Link for SPDT/SPCO
		8 Contact Type D8, X8, P8, H8, E8 D.P.D.T. 4 x S.P.S.T AA Make on Rise  B BB Make on Fall  B Link for DPDT/DPCO



OUR WARRANTY

All mechanical level devices are warranted free of defects in materials and workmanship for five years from the date of original factory shipment.

If returned within the stated warranty period, and upon factory inspection the cause of the claim is determined to be covered under the warranty, at option, the device will be repaired or replaced without cost to the purchaser (or owner), other than transportation.

Jerguson® shall not be liable for mis-application, labor claims, direct or consequential damage or expense arising from the installation or use of the equipment. There are no other warranties expressed or implied.

DIMENSIONAL AND OPERATING LEVEL DATA

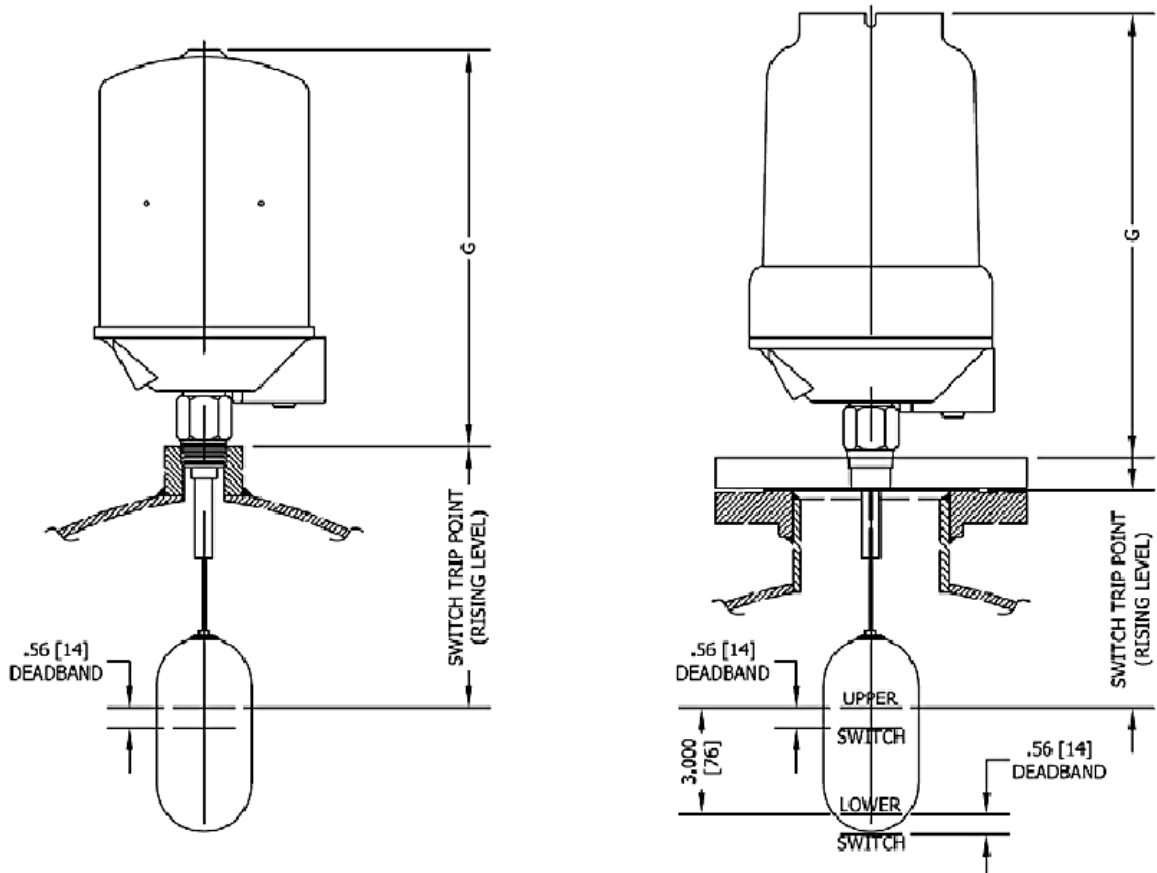

ENCLOSURE DIMENSIONAL DATA

Type	Duty	Height G	Conduit Thread	Switch Adjustment	Weatherproof Rating
SA7, SI7	Explosion-proof	13 1/4"	1" NPT	3 3/8"	NEMA 4 & 7
SA4	Weather-proof	12"	1" NPT	3 3/8"	NEMA 4

MATERIALS OF CONSTRUCTION

Technical Specifications	Designed in accordance with the requirements of B31.1 & B31.3.	
Materials of Construction	Carbon Steel Mounting Flange	Stainless Steel Mounting Flange
Flanges/Fittings	ASTM A105	ASTM A182F316
Float & Trim	316 SS	316 SS
Options:		
<ul style="list-style-type: none"> • Low temperature carbon steel chambers • Controls to meet NACE requirements • A comprehensive NDT package 		

ORDERING INFORMATION¹

TYPICAL MODEL

JDC1F SA4N 1 X4 D71 L09.50

MATERIAL OF CONSTRUCTION

JDC_F Top Mount Float Switch (CS)			
MODEL	SPDT MIN. S.G. ²	DPDT MIN. S.G. ²	FLOAT RATING ³
JDC1F	0.72	0.80	350 PSIG @ 100°F, 275 PSIG @ 750°F
JDC2F	0.60	0.60	300 PSIG @ 100°F, 235 PSIG @ 750°F
JDC3F	0.65	0.69	740 PSIG @ 100°F, 505 PSIG @ 750°F
JDC4F	0.65	0.69	1440 PSIG @ 100°F, 935 PSIG @ 750°F
JDC5F	0.72	0.76	1000 PSIG @ 100°F, 780 PSIG @ 750°F
JDC6F	0.36	0.38	300 PSIG @ 100°F, 235 PSIG @ 750°F
JDC7F	0.47	0.49	750 PSIG @ 100°F, 585 PSIG @ 750°F
JDC8F	0.58	0.60	1000 PSIG @ 100°F, 780 PSIG @ 750°F
JDC9F	0.34	0.35	450 PSIG @ 100°F, 350 PSIG @ 750°F

Carbon Steel

JDS_F Top Mount Float Switch (SS)			
MODEL	SPDT MIN. S.G. ²	DPDT MIN. S.G. ²	FLOAT RATING ³
JDS1F	0.72	0.80	350 PSIG @ 100°F, 275 PSIG @ 750°F
JDS2F	0.60	0.60	300 PSIG @ 100°F, 235 PSIG @ 750°F
JDS3F	0.65	0.69	720 PSIG @ 100°F, 425 PSIG @ 750°F
JDS4F	0.65	0.69	1440 PSIG @ 100°F, 935 PSIG @ 750°F
JDS5F	0.72	0.76	1000 PSIG @ 100°F, 780 PSIG @ 750°F
JDS6F	0.36	0.38	300 PSIG @ 100°F, 235 PSIG @ 750°F
JDS7F	0.47	0.49	750 PSIG @ 100°F, 585 PSIG @ 750°F
JDS8F	0.58	0.60	1000 PSIG @ 100°F, 780 PSIG @ 750°F
JDS9F	0.34	0.35	450 PSIG @ 100°F, 350 PSIG @ 750°F

Stainless Steel

ENCLOSURE TYPES

Code	Duty	Material of cover	Material of base	Material of pressure	Material of screwed	Maximum number of switches
SA4N	Weather-proof	Aluminum Alloy		316	To match chamber material	1-2
SA7F	Explosion-proof Factory Mutual Cl.I,Div.1,Grps B,C & D	Drawn Steel	Aluminum Alloy	Stainless Steel	To match chamber material	1-2

Enclosure

Notes:
¹ Completed Application Design Sheet Required (JS200.08)
² For approximation only, 'Lowest Switch Trip Point' < 12.00". Actual min. SG dependent on the final design.
³ Final pressure rating of the unit is the lower rating between float & process connection.
⁴ Specify rising level switch point for single switch, or upper switch of multi-switch model. Falling level 0.56" below rising level. Refer to sketch on page 3.

Lowest Switch Trip Point (Rising Level⁴)

Length (In inches)

PROCESS CONNECTION

CODE	SIZE	CARBON STEEL RATING ³	SST RATING ³	NOTES
D2M	1" NPT	1000 PSIG @ 100°F	1000 PSIG @ 100°F	Requires internal access to attach float (float is larger than 1" NPT)
D71	3" 150# R.F. ASME	285 PSIG @ 100°F	275 PSIG @ 100°F	Model JDC1F/JDS1F only, unless internal access is available
D73	3" 300# R.F. ASME	740 PSIG @ 100°F	720 PSIG @ 100°F	
D76	3" 600# R.F. ASME	1480 PSIG @ 100°F	1440 PSIG @ 100°F	
D91	4" 150# R.F. ASME	285 PSIG @ 100°F	275 PSIG @ 100°F	
D93	4" 300# R.F. ASME	740 PSIG @ 100°F	720 PSIG @ 100°F	Model JDC1F/JDS1F on all nozzle schedules, 2F-4F to Sch. 80S
D96	4" 600# R.F. ASME	1480 PSIG @ 100°F	1440 PSIG @ 100°F	
DB1	6" 150# R.F. ASME	285 PSIG @ 100°F	275 PSIG @ 100°F	Model JDC1F/JDS1F on all nozzle schedules, 6F-9F to Sch. 80S
DB3	6" 300# R.F. ASME	740 PSIG @ 100°F	720 PSIG @ 100°F	
DB6	6" 600# R.F. ASME	1480 PSIG @ 100°F	1440 PSIG @ 100°F	Model JDC1F/JDS1F only
D7M	3" MNPT	1000 PSIG @ 100°F	1000 PSIG @ 100°F	

SWITCH MECHANISM TYPES

	Temp Wet-side °F	AC max. values			DC Max. values			
		VA	Volts	Amps	Watts	Volts	Res. Amps	Ind. Amps
X4 D4 H4 E4 P4 4 Contact A B A B Link for SPDT Two independent single pole single throw contact sets	480	2000	440	10	50	250	10	0.5
	750	2000	440	5	50	250	5	0.5
	480	2000	440	5	50	250	5	0.5
	850	2000	440	5	50	250	5	0.5
X8 D8 H8 E8 P8 8 Contact A B A B Link for DPDT Four independent single pole single throw contact sets	480	2000	440	10	50	250	10	0.5
	750	2000	440	5	50	250	5	0.5
	480	2000	440	5	50	250	5	0.5
	850	2000	440	5	50	250	5	0.5
	750	6	250	0.25	3.6	250	0.25	0.1

Switch Mechanism

NUMBER OF SWITCH MECHANISMS

Specify No. of Switches Required (1,2)

No. of Switches

JERGUSON® "FIT & FORGET" PRODUCTS PROVIDE THE SOLUTION TO YOUR LIQUID LEVEL CONTROL PROBLEMS

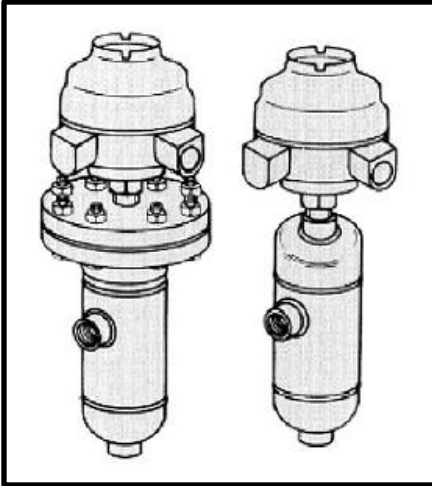

Medium Pressures
ASME Class 150, 300, 600
SG 0.40

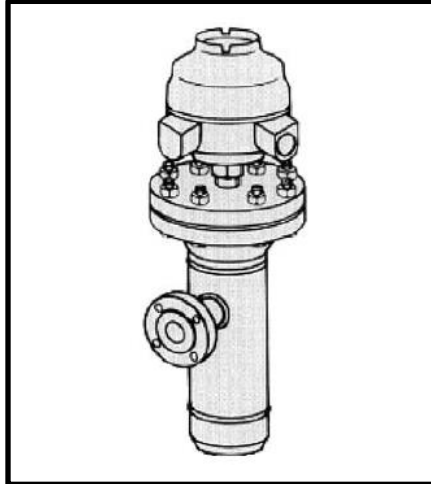

High Pressure
ASME Class 900, 1500, 2500
SG 0.40

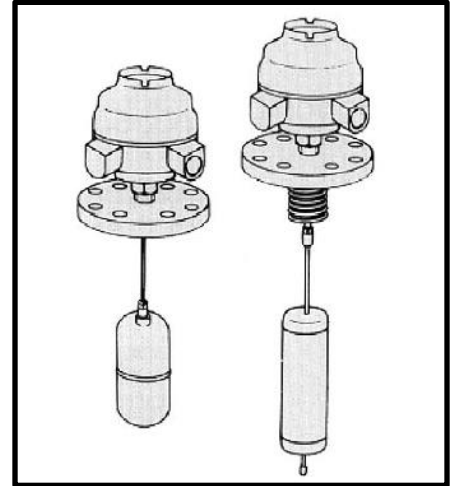

Direct Mounting
ASME Class 150, 300, 600
SG 0.40

You can rely on us

The Jerguson range of liquid level controls is designed for operation in a wide variety of applications.

Typical Applications

Separators	Water Sumps
Compressors	Scrubbers
Knock Out Pots	Fractioning Columns
Condensors	Process Vessels
De-actuators	Condensate Tanks
Storage Tanks	Drainpots
Service Tanks	Accumulators
Header Tanks	Flush Vessels
Effluent Sumps & Tanks	Fuel Tanks
Heat Exchanger	Feedwater Heaters
Lube Oil Tanks	Surge Drums

Jerguson level switches are used for the control of liquids by companies all over the world.

Shell	Bechtel
Exxon	Bellili
Amoco	Ontario Hydro
Fluor	Nissaci-Sangyo
Hyundai	Foster Wheeler
Hitachi	Siemens
British Petroleum	Mannesmann-Demag
Mobil	Catalytic
Texaco	Techni
Ingersoll Rand	Technipetrol
Compare	Nuovo Pignone
Honeywell	Dresser

Instrumentation & Control

JERGUSON®



Level Gages
Magnetic Level Gages
Switches & Valves

JACOBY·TARBOX®



Sight Flow Indicators
Sight Windows
Eductors

Reliance®



Boiler Level Gages
Remote Level Indicators
Boiler Safety Instruments

Filtration & Purification

ANDERSON®
Separator



Gas Coalescing & Filtration
Steam Separators & Traps
Liquid Particle Filtration

Enervac™
INTERNATIONAL ULC



Transformer Oil Purification
SF6 Equipment
Air Dryers

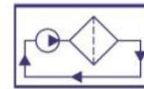

**OIL
FILTRATION
SYSTEMS®**



Vacuum Dehydrators
Varnish Removal Systems
Hi & Low Flow Filter Skids

Elements, Internals, Parts & More



www.clark-reliance.com / www.clark-reliance.com/parts