

PRESSURE CONTROL

Pressure reducing valve DM 618

Standard valve for medium to high flow rates



Technical data

Connection DN	15 - 100
Nominal pressure PN	16 - 40
Inlet pressure	up to 40 bar
Outlet pressure	0.3 - 10 bar
K_{vs} value	3.6 - 100 m ³ /h
Temperature	130 °C
Medium	liquids and gases
*RT = -10 °C TO + 50 °C	

Description

Self-acting pressure reducers are simple control valves offering accurate control while being easy to install and maintain. They control the pressure downstream of the valve without requiring pneumatic or electrical control elements.

The pressure reducing valve DM 618 is a diaphragm-operated, spring-loaded and balanced proportional valve for high flow rates.

The valve body is made of cast steel. Diaphragm housing, bonnet and internal parts are made of stainless steel 1.4404 (316L). The valve cone is fitted with a soft seal.

The outlet pressure to be controlled is balanced across the control unit by the force of the valve spring (set pressure). As the outlet pressure rises above the pressure set using the adjusting screw, the valve cone moves towards the seat and the volume of medium is reduced. As the outlet pressure drops, the valve control orifice increases; when the pipeline is depressurised, the valve is open. Rotating the adjusting screw clockwise increases the outlet pressure.

The valve requires a sense line (to be installed on-site).

These valves are no shut-off elements ensuring a tight closing of the valve. In accordance with DIN EN 60534-4 and/or ANSI FCI 70-2 they may feature a leakage rate in closed position in compliance with the leakage classes V optional IV.

Standard

- » Body made of 1.0619 (GS-C25 / A216-WCB)
- » Diaphragm housing, bonnet and internal parts made of stainless steel 1.4404 (316L)
- » Leakage line connection and sealed adjusting screw
- » Balanced cone for controlling the outlet pressure independently from the inlet pressure
- » Sense line connection
- » EPDM elastomers

Options

- » Body made of stainless steel 1.4408 (CF8M)
- » FKM elastomers (O-rings)
- » PTFE protective foil for the diaphragm

Typical applications

- » Conventional fuel supply and residues disposal (e.g. KKS code: EKG, ENX)
- » Water supply and disposal – distribution system (e.g. KKS code: GHC, GQA)
- » Drying of solid matter (e.g. KKS code: HTN)
- » Conventional heat generation (e.g. KKS code: HTQ)
- » Steam, water, gas cycle condensate system (e.g. KKS code: LCA, LCW)
- » Water treatment and distribution (e.g. KKS code: PCB)
- » Cooling water systems (e.g. KKS code: PCC)
- » Generation of working air (e.g. KKS code: SCA)

When placing the order

When placing the order:

» Nominal diameter DN	» Nominal pressure PN
» K_{vs} value	» Pressure range
» Body material	» Elastomers

Ex.: DM 618, DN 50, PN 40, K_{vs} 40 m³/h, 2 - 5 bar, GS-C25, EPDM

Please send us your enquiry and allow us to advise you. Special designs on request.

The pressure has always been indicated as overpressure. Mankenberg reserves the right to alter technical specifications without notice.

Product



Picture similar

Technical specification

K_{vs} values [m³/h]

DN	15	20	25	32	40	50	65	80	100
min. m ³ /h	0.8	0.8	0.8	1	1	1	1	1	1
0.3 - 1.1 bar	3.6	6	6	16	27	35	45	50	55
0.8 - 10 bar	4.5	8	8	16	27	35	80	90	100

Setting ranges [bar]

0.3 - 1.1	0.8 - 2.5	2 - 5	4.5 - 10
-----------	-----------	-------	----------

Max. operating pressures PS [bar] with operating temperature TS [°C]

TS °C	-10	130
PS bar	40	38

Reduction ratio (max. p_1/p_2) [bar]

setting range bar	nominal diameter DN		
	15 - 25	32 - 50	65 - 100
4.5 - 10	10 : 1	8 : 1	5 : 1
2 - 5	20 : 1	15 : 1	8 : 1
0.8 - 2.5	30 : 1	20 : 1	12 : 1
0.3 - 1.1	15 : 1	11 : 1	6 : 1

E.g.: set pressure 0.8 bar = max. inlet pressure 24 bar (30 x 0.8)

Attention: The max. allowable operating pressure must be observed!

PRESSURE CONTROL

Pressure reducing valve DM 618

Standard valve for medium to high flow rates



Materials

Materials*		
1	Body	1.0619 (GS-C25 / A216-WCB), optionally made of stainless steel 1.4408 (CF8M)
2	Diaphragm housing	Stainless steel 1.4404 (316L)
3	Bonnet	Stainless steel 1.4404 (316L)
	Internal parts	Stainless steel 1.4404 / 1.4462 (316L / Duplex)
4	Valve seal	EPDM optionally FKM
5	Diaphragm	EPDM optionally FKM, PTFE protection foil
6	O-ring	EPDM optionally FKM

*All materials equal or of higher quality

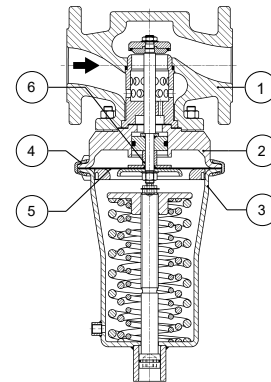

Dimensions and weights

Dimensions [mm]										
size	nominal diameter DN									
	15	20	25	32	40	50	65	80	100	
A*	130	150	160	180	200	230	290	310	350	
B	60	60	60	75	75	75	112	112	112	
C	278	278	278	438	438	438	508	508	508	
D	G 1/8	G 1/8	G 1/8	G 1/4	G 1/4	G 1/4	G 1/4	G 1/4	G 1/4	
øE	115	115	115	208	208	208	220	220	220	

*overall length tolerances in acc. with DIN EN 558

Weights [kg]										
nominal diameter DN										
15	20	25	32	40	50	65	80	100		
9	10	11	31	33	35	64	66	73		

Customs tariff number

84811019

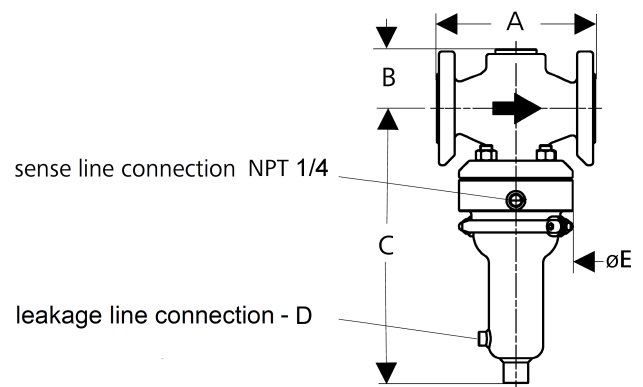

Recommended installation

- | | | | |
|---|------------------------|---|--------------------------|
| 1 | Bypass for maintenance | 5 | Safety valve |
| 2 | Shut-off valves | 6 | Pressure reducing valve* |
| 3 | Strainer | 7 | Sense line* |
| 4 | Pressure gauge | 8 | Leakage line |

*Sense line connection 10 - 20 x DN behind the valve
 Installation in a horizontal line without strain with the spring cap pointing vertically downwards in such a way that the arrow on the body points in the direction of flow. For gases, the installation can take place with the spring cap pointing either downwards or upwards. For use with liquids the valve must be installed with the spring cap pointing downwards.

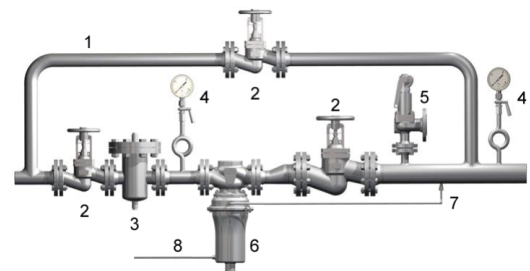

Flow characteristics

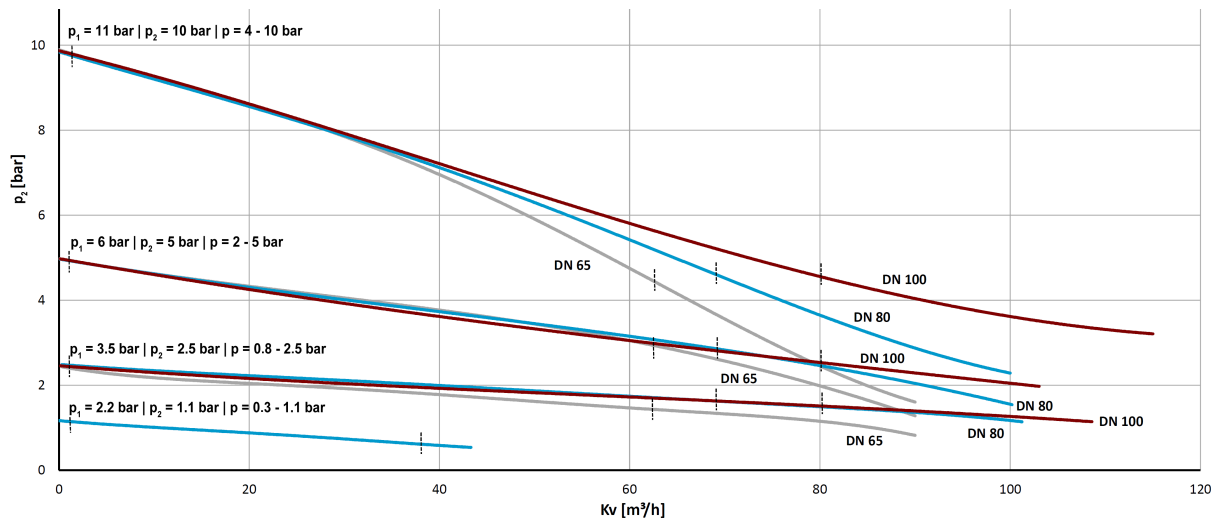
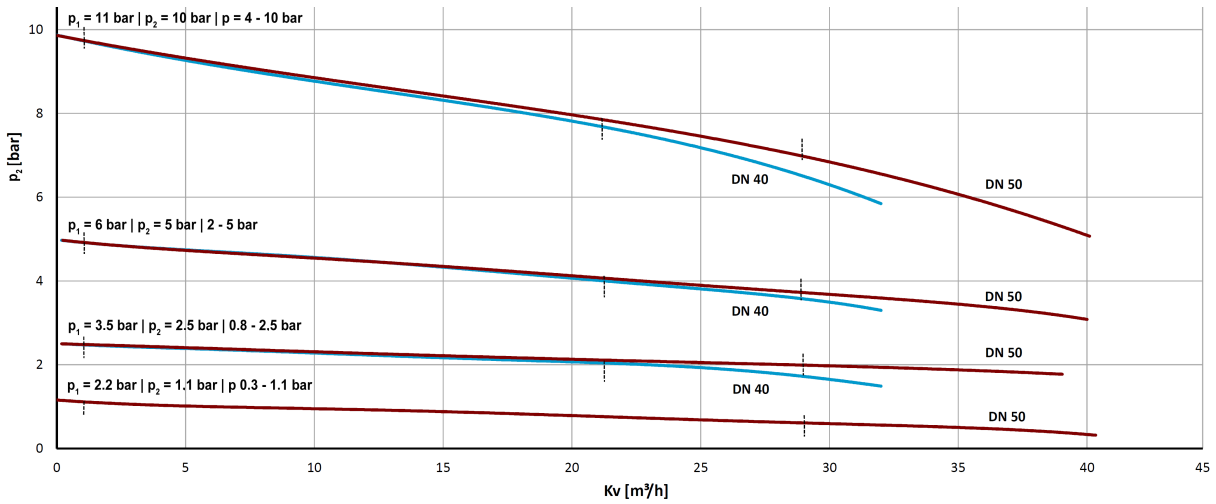
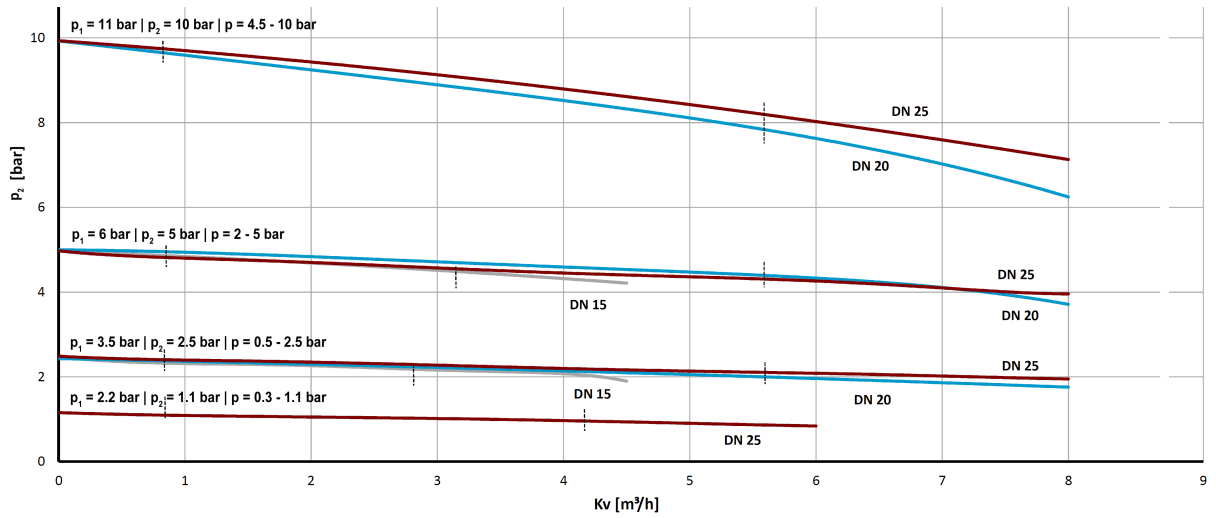

p = pressure range p_1 = inlet pressure p_2 = adjusted outlet pressure | = recommended working range

Please also consider the related article [How to read flow characteristics](#).

Please send us your enquiry and allow us to advise you. Special designs on request.
The pressure has always been indicated as overpressure. Mankenberg reserves the right to alter technical specifications without notice.

Authorised Distributor:



46, Jalan SS 22/21, Damansara Jaya,
47400 Petaling Jaya,
Selangor Darul Ehsan, Malaysia.
Email: ampmech@ampmech.com
Website: www.ampmech.com