

LEVEL CONTROL

Bleeding and venting valve EB 1.10 1.11

Continuous bleeding valve for high to very high flow rates



Technical data

Connection DN	32/15 - 100/50
Nominal pressure PN	40
Operating pressure	0 - 40 bar
Flow rate	2440 Nm ³ /h
Temperature	200 °C
Medium	liquids

Description

Bleeding and venting valves remove air or gases from systems or pipelines without requiring an external energy input. When a system is drained they act as venting valves; venting may be prevented by fitting a non-return valve. The EB 1.10 and EB 1.11 bleeding/venting valves are float-controlled robust valves made of spherical-graphite cast iron or cast steel to handle large air volumes e.g. in sand filters. The internal components are made of stainless steel featuring excellent corrosion resistance. Up to 130 °C the valve cone is fitted with a soft seal; up to 200 °C the seal is metallic. EB 1.11 is fitted with an external float and specially suitable for foaming and contaminated media. The simple design makes it easy to specify, install, handle and service these valves in an industrial environment.

Valves for continuous bleeding must not be overdimensioned. If a larger valve size is selected, a higher working pressure range with a correspondingly lower flow volume should be chosen. In case of doubt we shall be happy to advise you.

On filter vessels the bleed connection is often located in the middle of the vessel. If the flow volume is large and the distance between distribution funnel and bleed connection small, the incoming water jet hits the bleed connection. This will impair the efficiency of the bleed valve and can result in water hammer. This problem may be avoided by installing a baffle or by placing the bleed connection away from the centre.

For the EB 1.11 the supplied float rod guide is to be installed in such a way that the float rod will be vertically guided. It must not obstruct the lift movement of the float.

Standard

- » Manual bleed valve made of stainless steel (supplied loose and must be fitted on-site)
- » EB 1.11 with float rod guide (must be fitted on-site)

Options

- » Rubber or plastic coating for corrosive fluids
- » non-return valve to avoid venting
- » Special versions on request

Product



Picture similar

Technical specification

Pressure ranges [bar]

PN 16	0 - 2	0 - 6	0 - 10	0 - 16	-	-
PN 40	0 - 2	0 - 6	0 - 10	0 - 16	0 - 25	0 - 40

Please state working pressure range when enquiring or ordering.

Materials

Materials*			
Temperature		130 °C	80°C
Body	PN 16	spheroidal cast iron	spheroidal cast iron
	PN 25/40	cast steel	cast steel
Body seal		nova universal	nova universal
Internals		stainless steel	stainless steel
Float		stainless steel	stainless steel
Valve seal		FKM	metallic

*All materials equal or of higher quality

Dimensions and weights

Dimensions [mm]							
nom. pressure PN	size	nominal diameter DN					
		32/15	40/20	50/25	65/32	80/40	100/50
16	A*	120	130	140	160	185	205
	B	70	95	95	105	110	180
	C	260	240	250	270	315	375
	D	205	225	245	270	315	355
25/40	A*	130		160		200	
	B	70		100		110	
	C	275		260		385	
	D	225		270		350	

*overall length tolerances in acc. with DIN EN 558

Weights [kg]							
nom. pressure PN	nominal diameter DN						
	32/15	40/20	50/25	65/32	80/40	100/50	
16	11	14	18	23	31	45	
25/40	18		23		41		

Float dimensions [mm] EB 1.11							
pressure ranges [bar]	size	nominal diameter DN					
		32/15	40/20	50/25	65/32	80/40	100/50
0 - 2 / 0 - 6	E	110	110	110	130	160	180
0 - 10		110	130	130	150	180	200
0 - 16		120	150	150	180	200	200
0 - 25 / 0 - 40		150		180		280	

The quoted flow volumes apply to a fully open valve i.e. in start-up condition at 0 °C and 1013 mbar. With continuous bleeding e.g. of filter vessels, the maximum flow volume is 30 % less on average.

Please note: Smaller seat diameter for higher pressure range. If the selected working pressure range is too high, the flow volume may be inadequate.

Customs tariff number	
84818059	

only with DN 32/15 (PN 16 and 40) and DN 80/40 (only PN 40)

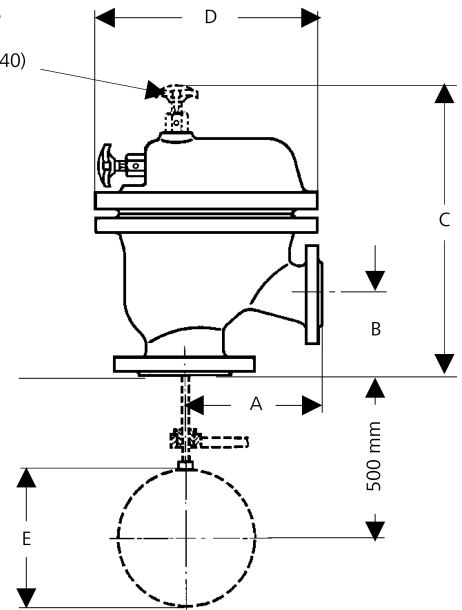

Appendix

Seat diameter [mm] EB 1.10

pressure range bar	nominal diameter DN					
	32/15	40/20	50/25	65/32	80/40	100/50
0 - 2	6	7.5	8	10	13	16
0 - 6	4	4.5	5	6	9	12
0 - 10	3	3.5	4	5	7.5	10
0 - 16	2	2.5	3.5	4	5.5	8
0 - 25	2		3		4.5	
0 - 40	1.5		2		3.5	

Seat diameter [mm] EB 1.11

pressure range bar	nominal diameter DN					
	32/15	40/20	50/25	65/32	80/40	100/50
all ranges	6	7.5	8	10	13	16

Air flow [Nm³/h] at 0°C 1013 mbar

seat ø mm	differential pressure Δp bar														
	0.1	0.5	1	2	4	6	8	10	12	16	20	25	30	35	40
1.5	0.5	1.2	1.5	2.3	3.9	5.5	7.1	8.7	10	13	16	20	24	28	32
2	1	2.2	2.8	4.2	7	9.8	12	15	18	24	29	36	43	50	57
2.5	1.6	3.4	4.4	6.6	11	15	19	24	28	37					
3	2.3	5	6.3	9.5	15	22	28	34	41	54	66	82			
3.5	3.1	6.8	8.6	12	21	30	38	47	56	73	90	112	133	155	176
4	4.1	8.9	11	16	28	39	50	62	73	95					
4.5	5.2	11	14	21	35	50	64	78	93	121	150	185			
5	6.4	13	17	26	44	61	79	96							
5.5	8	16	21	32	53	75	96	118	139	182					
6	9.3	20	25	38	63	88	114	140	165	216	266	330	393	456	520
7.5	14	31	39	59	99	138	178	218	258	336					
8	16	35	45	67	113	157	203	248	293	383	473	586	697	810	923
9	21	45	57	85	143	200									
10	25	55	70	106	176	246	317	388	459	599					
12	37	80	102	152	254	355									
13	43	94	119	178	298	416	535	655	774	1010	1250	1550	1840	2140	2440
16	66	143	180	270	451	630	811	992	1170	1530					

The quoted flow volumes apply to a fully open valve i.e. in start-up condition at 0 °C and 1,013 mbar. With continuous bleeding e.g. of filter vessels, the maximum flow volume is 30 % less on average.

Please note: Smaller seat diameter at higher pressure range. If the selected working pressure range is too high, the flow volume may be inadequate.

Mankenberg GmbH | Spenglerstrasse 99 | D-23556 Luebeck | Germany

Authorised Distributor:



46, Jalan SS 22/21, Damansara Jaya,
47400 Petaling Jaya,
Selangor Darul Ehsan, Malaysia.

Email: ampmech@ampmech.com
Website: www.ampmech.com

Please send us your enquiry and allow us to advise you. Special designs on request.
The pressure has always been indicated as overpressure. Mankenberg reserves the right to alter technical specifications without notice.