

# Bleeding and venting valves

## Bleeding and venting valves SCF (EB 1.85)

Epoxy-coated cast valve for waste water



### Technical Data

Connection DN	50 - 200
Connection G	2
Nominal pressure PN	10 - 16
Operating pressure	0.3 - 16 bar
Flow rate	bleeding up to 4200 Nm <sup>3</sup> /h venting up to 4100 Nm <sup>3</sup> /h continuous bleeding up to 32 Nm <sup>3</sup> /h
Temperature	70 °C
Medium	wastewater and sewage

### Description

Bleeding and venting valves remove air or gases from systems or pipelines without requiring an external energy input. When a system is drained they act as venting valves.

SCF (EB 1.85) is a combined start-up and continuous bleeding and venting valve with float control. During start-up a large quantity of air is removed at low pressure via a large cone. If the ventilator is closed and further small quantities of air occur in continuous operation, an additional small seat opens and removes the air present. The large cone does not open until the level drops and pressure decreases at the same time. In the case of underpressure the valves open immediately. The minimum pressure for the valve seal is 0.2 bar.

The SCF (EB 1.85) is a float-controlled bleeding and venting valve for wastewater and sewage as well as for foaming media. An enlarged float housing prevents contact between the wastewater and the upper section of the closing mechanism. The housings are made of spheroidal graphite iron with a continuous epoxy coating and are therefore outstandingly well protected. The valve cone is soft-sealed.

The upper and lower sections of the valve unit are each connected by means of only 4 screws. Maintenance work can be performed rapidly and without the need for special tools.

### Standard

- » Designed acc. to EN-1074/4
- » Flanges as per EN 1092/2
- » Body made of spheroidal cast iron GJS 450-10 with epoxy coating in blue RAL 5005, thickness min. 250 µm
- » Internal parts made of stainless steel 1.4301, 1.4404 and PP
- » Float made of stainless steel 1.4404
- » Purging connection made of 1.4404
- » Flanged valves with degassing bend made of polypropylene PP
- » Coating as per DVGW W270 and KTW recommendation of the German Ministry for Health

### Options

- » Pressure surge attenuation by anti-shock-system for closing smoothly and controlled
- » Air discharge only
- » Vacuum breaker version
- » Special designs on request

Operating instructions, know how and safety instructions must be observed. The pressure has always been indicated as overpressure. We reserve the right to alter technical specifications without notice.



**Air Flow Rate [m<sup>3</sup>/h] at 0°C, 1013 mbar, Nominal Pressure PN for standard design**

	ΔP bar	nominal diameter						
		G 2	DN 50	DN 65	DN 80	DN 100	DN 150	DN 200
venting	0.05	75	200	200	700	700	1600	1600
	0.1	110	260	260	1000	1000	2300	2300
	0.3	180	480	480	1750	1750	4100	4100
start-up bleeding	0.05	75	200	200	800	800	1500	1500
	0.1	100	260	260	1150	1150	2250	2250
	0.3	195	500	500	1900	1900	4200	4200
continuous bleeding	2	3.5	3.5	3.5	4.5	4.5	6.5	6.5
	4	7	6.5	6.5	7	7	13	13
	6	9.5	7.5	7.5	10	10	18	18
	8	14	12	12	16	16	28	28
	10	16	13	13	18	18	32	32
	16	25	20	20	30	30		
nom. press.	PN	16	16	16	16	16	10	10

**Air Flow Rate [m<sup>3</sup>/h] at 0°C, 1013 mbar, Nominal Pressure PN with anti-hammer system**

	ΔP bar	nominal diameter						
		G 2	DN 50	DN 65	DN 80	DN 100	DN 150	DN 200
venting	0.05	75	200	200	450	450	1200	1200
	0.1	100	300	300	650	650	1650	1650
	0.3	180	480	480	1150	1150	2800	2800
start-up bleeding	0.05	4.5	8	8	18	18	40	40
	0.1	6.5	11	11	25	25	60	60
	0.3	11	20	20	45	45	110	110
continuous bleeding	2	3.5	without continuous venting					
	4	7						
	6	10						
	8	14						
	10	18						
	16	27						
nom. press.	PN	16	10	10	10	10	10	10

# Bleeding and venting valves

## Bleeding and venting valves SCF (EB 1.85)

Epoxy-coated cast valve for waste water



Materials	
Body	spheroidal cast iron GJS 450-10 epoxy coated*
Body Seal	NBR optional EPDM, Viton or silicone
Internals	stainless steel 1.4301, 1.4404 and polypropylene PP
Float	stainless steel 1.4404
Valve Seal	NBR optional EPDM, Viton or silicone
Purging Valve	stainless steel 1.4404

\* in accordance with KTW-recommendation and DVGW W270, thickness min. 250 µm

Dimensions [mm] for sleeve connection				
size	SCF (EB 1.85)		SCF-AS* (EB 1.85-AS)	
	inlet female G 2 outlet male G 1		inlet female G 2 outlet male G 1	
A	1'		1'	
B	380		389	
C	2'		2'	
D	137		137	

Weights [kg] for sleeve connection		
SCF (EB 1.85)	SCF-AS* (EB 1.85-AS)	
10.5	10.8	

\* with anti-hammer system

Dimensions [mm] for flange connection							
size	nominal diameter DN						
	50	65	80	100	150	200	
A	185	185	220	220	285	340	
B	650	650	700	700	950	950	
C	300	300	300	350	488	488	
D	202	202	208	190	243	243	
E	1 1/2"	1 1/2"	2 1/2"	2 1/2"	4"	4"	

Weights [kg] for flange connection						
nominal diameter DN						
50	65	80	100	150	200	
29	29	40	40	78	82	

Customs Tariff Number
84818059

Special designs on request.  
The pressure has always been indicated as overpressure.  
Mankenberg reserves the right to alter or improve the designs or specifications of the products described herein without notice.

### Dimensional Drawing

Sleeve Connection

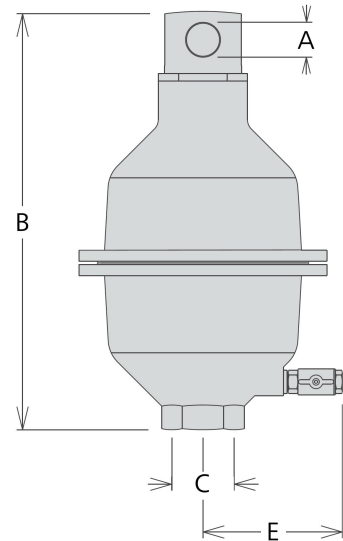

Flange Connection

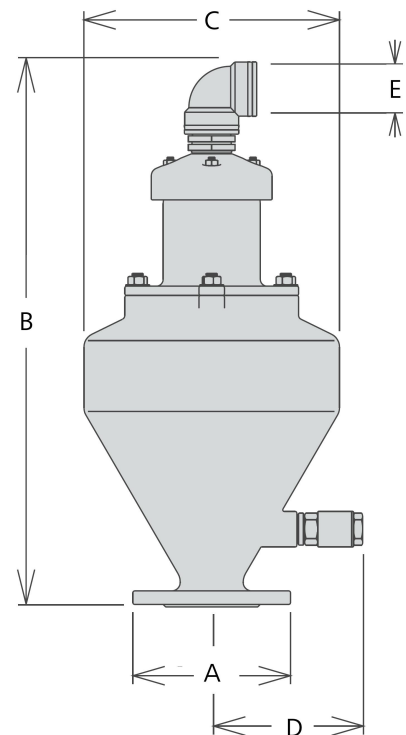

Authorised Distributor:



46, Jalan SS 22/21, Damansara Jaya,  
47400 Petaling Jaya,  
Selangor Darul Ehsan, Malaysia.

Email: [ampmech@ampmech.com](mailto:ampmech@ampmech.com)  
Website: [www.ampmech.com](http://www.ampmech.com)