

# Float Valves

## Float Valves ATHENA (NV 15e)

Epoxy-coated Cast Valve



### Technical Data

Connection DN	40 - 300
Nominal Pressure PN	16
Operating Pressure	0 - 16 bar
K <sub>vs</sub> -Value	18 - 1008 m <sup>3</sup> /h
Temperature	70 °C
Medium	water, especially potable water

### Description

Float valves automatically control liquid levels in sealed or open (non-pressurised) tanks and vessels without requiring external energy. The float registers the liquid level and directly controls the valve via a lever. A change in the liquid level immediately results in a changed flow volume.

ATHENA (NV 15e) is a straightway or angle-type single-seat feed valve with relieved cone, the cone is fitted with a soft seal. The valves are approved for the use with potable water thanks to the coating of the body in accordance with the KTW guidelines.

The valves are equipped with a float rod that is height-adjustable through the lever. Thus the fluid level can be steplessly adjusted.

### Standard

- » Body made of spheroidal cast iron GJS 450-10 with epoxy coating in blue RAL 5005, thickness min. 250 µm
- » Float rod made of stainless steel 1.4301
- » Up to DN 65 ball float made of stainless steel  
From DN 80 shell-type float with internal pipe made of CrNiMo steel

### Options

- » Float lever made of CrNiMo steel
- » Float lever can be rotated on site, with an angle of 45°/90°
- » EPDM seals
- » Connection for frost protection G 3/8

Operating instructions, know how and safety instructions must be observed. The pressure has always been indicated as overpressure. We reserve the right to alter technical specifications without notice.



### K<sub>vs</sub> Values [m<sup>3</sup>/h] Angled Design

nominal diameter DN	40	50	65	80	100
m <sup>3</sup> /h	20	20	45	65	105

### K<sub>vs</sub> Values [m<sup>3</sup>/h] Angled Design

nominal diameter DN	125	150	200	250	300
m <sup>3</sup> /h	155	245	360	645	1005

### K<sub>vs</sub> Values [m<sup>3</sup>/h] Straight-way Design

nominal diameter DN	40	50	65	80	100
m <sup>3</sup> /h	15	15	35	55	90

### K<sub>vs</sub> Values [m<sup>3</sup>/h] Straight-way Design

nominal diameter DN	125	150	200	250	300
m <sup>3</sup> /h	130	205	310	575	860

### Lever Position

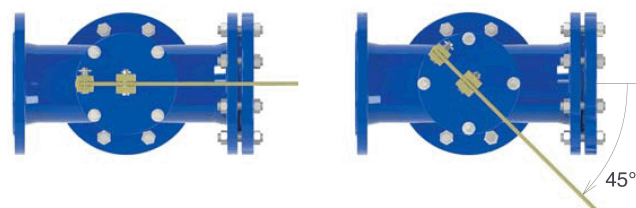

The lever mechanism is normally aligned with the valve axis. It is possible to rotate it on site, with an angle of 45°/90°, to fit the installation requirements.

# Float Valves

## Float Valves ATHENA (NV 15e)

Epoxy-coated Cast Valve



Materials	
Body and Cover	spheroidal cast iron GJS 450-10 Epoxy-coated*
Guide Bush	brass or steel optional stainless steel 1.4301 or 1.4404
Cone and Seat	stainless steel 1.4301 optional 1.4404
Cone Guide	PTFE
Valve Seal	NBR optional EPDM or FKM
Lever	zinc-plated steel optional stainless steel 1.4301 or 1.4404
Float Road	stainless steel 1.4301 optional 1.4404
Float	stainless steel 1.4301 optional 1.4404

\* in accordance with KTW-recommendation and DVGW W270, thickness min. 250 µm

Dimensions [mm] and Weights [kg] PN 10/16*											
size	nominal diameter DN										
	40	50	65	80	100	125	150	200	250	300	
A	230	230	290	310	350	400	480	600	730	850	
B	82.5	82.5	92.5	100	125	125	162	183	270	300	
C	173	173	193	212	225	230	351	380	540	610	
D	600	600	600	800	800	800	1000	1000	1220	1400	
E	525	525	525	600	600	600	600	600	945	1042	
kg	21	21	25.6	32.6	41	49	78.5	118	162	250	

Float Dimensions [mm]											
size	nominal diameter DN										
	40	50	65	80	100	125	150	200	250	300	
ø	220	220	220	300	400	400	400	400	500	500	
height				200	180	180	250	250	300	400	

from DN 40 up to DN 65 with ball float  
from DN 80 up to DN 300 with cylindrical float

Customs Tariff Number
84818059

Special designs on request.  
The pressure has always been indicated as overpressure.  
Mankenberg reserves the right to alter or improve the designs or specifications of the products described herein without notice.

### Dimensional Drawing

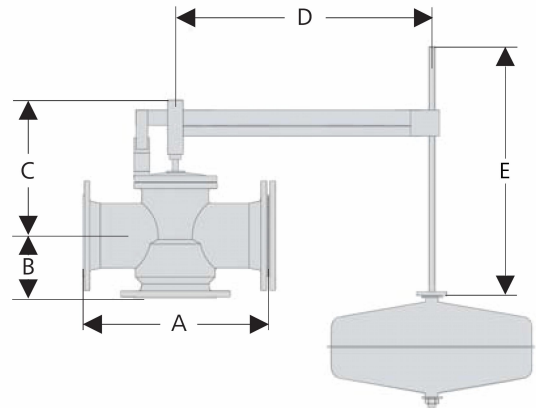

#### Authorised Distributor:



46, Jalan SS 22/21, Damansara Jaya,  
47400 Petaling Jaya,  
Selangor Darul Ehsan, Malaysia.  
Email: [ampmech@ampmech.com](mailto:ampmech@ampmech.com)  
Website: [www.ampmech.com](http://www.ampmech.com)