

SL15 status lights range

Ex d, weatherproof



Overview

These status lights have been designed for use in potentially explosive atmospheres and harsh environmental conditions.

The indicators are suitable for use offshore or onshore, where a high degree of corrosion resistance is required.

The housings are manufactured from a UV stable, glass reinforced polyester (GRP) fitted to a stainless steel mounting plate for ease of installation. Stainless steel fixings are also used, ensuring a corrosion free product.

Units can be painted to customer specification and supplied with identification labels.

Units can be supplied as 2, 3 or 4 way in any combination.

Features

- Zone 1 and Zone 2 use
- ATEX certified
- Ex II 2GD
- IECEx certified Gb, Db
- UL certified (see US data sheet)
- IP66 and 67
- Certified temperature: -55°C to +70°C*
- Corrosion free GRP
- Filament 60W
- High powered LED flashing or steady
- Various flash rates available for xenon & LED units
- Various lens colours
- Optional cast or wire lens guard
- High powered LED flashing or steady

*Model dependent



Authorised Distributor:



46, Jalan SS 22/21, Damansara Jaya,
47400 Petaling Jaya,
Selangor Darul Ehsan, Malaysia.
Email: ampmech@ampmech.com
Website: www.ampmech.com

Eaton
Unit B, Sutton Parkway
Oddicroft Lane
Sutton in Ashfield
United Kingdom
NG17 5FB

T: +44 (0) 1623 444 400
www.crouse-hinds.com/hac
MEDCSales@Eaton.com

© 2018 Eaton
All Rights Reserved
Printed in UK
Publication
No.DSMC0025/B
February 2018

Eaton is a registered trademark.

All other trademarks are property of their respective owners.



Please check here for latest version of the datasheet



Powering Business Worldwide

Certifications

ATEX Ex d	Cert. no. Baseefa 04ATEX0009X Certified to: EN60079-0, EN60079-1, EN60079-31, (EN60079-28 LED only) Xenon: Ex II 2GD Ex db IIC T4/T5/T6 Gb, Ex tb IIIC T85°C/T100°C/T135°C Db LED: Ex II 2GD Ex db op is IIC T5/T6 Gb, Ex tb op is IIIC T85°C/T100°C Db Filament: Ex II 2GD Ex db IIC T3/T4 Gb, Ex tb IIIC T135°C/T200°C Db
IECEX Ex d	Cert. no. IECEX BAS 05.0048X Certified to: IEC60079-0, IEC60079-1, IEC60079-31 (IEC60079-28 LED only) Xenon: Ex db IIC T4/T5/T6 Gb. Ex tb IIIC T85°C/T100°C/T135°C Db LED: Ex db op is IIC T4/T5/T6 Gb. Ex tb op is IIIC T85°C/T100°C/T135°C Db Filament: Ex db IIC T3/T4 Gb. Ex tb IIIC T135°C/T200°C Db

Specifications

Material	Body: glass reinforced polyester Lens: glass Back plate & fixings: stainless steel 316 Wire guard (optional): stainless steel wire Cast guard (optional): aluminium LM25M
Finish	Natural black or painted to customer specification
Voltage	24, 48V d.c. - 110, 120, 230, 240, 254V a.c.
Xenon	Tube energy: 5, 10 or 15 joules Tube life: >1x10 ⁶ flashes Flash rate: 60, 80 or 120 fpm Certified temp: 15J -55°C to +70°C (T4), -55°C to +40°C (T5) 10J: -55°C to +70°C (T4), -55°C to +55°C (T5), -55°C to +40°C (T6) 5J: -55°C to +70°C (T5), -55°C to +55°C (T6)
Filament	Lamp type: 60W GLS filament Lamp holder: E27 as standard Certified temp: 60W -55°C to +55°C (T4) -55°C to +70°C (T3)
LED	Certified temp: -55°C to +55°C (T6) -55°C to +70°C (T5) LED life: up to 54,000 hours
Weight	2-Way: 6.5Kg, 3-Way: 9.8Kg, 4-Way: 13.1Kg
Ingress protection	IP66 & 67
Entries	Available with up to 2 x M20 or 2 x M25 entries in either bottom or top of unit. Entries in both bottom and top of unit by special order only
Terminals	Suitable for up to 2.5mm ² cable max
Labels	Tag/duty label option

General arrangement drawing (all dimensions in mm)

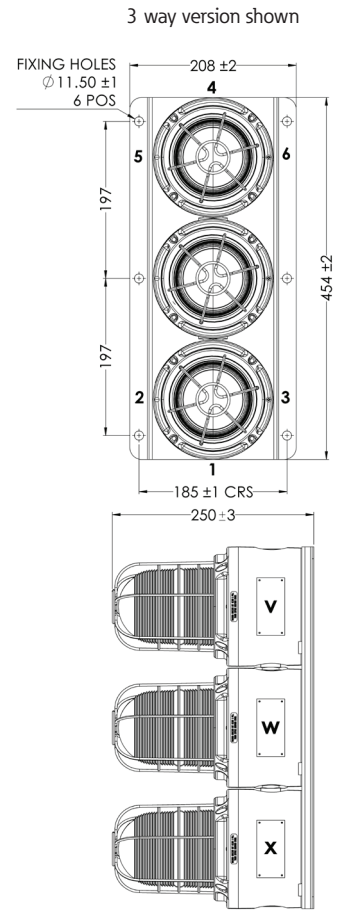

Current consumption per way (A):

Voltage	dc		ac (50Hz*)				
	24	48	110	120	230	240	254
5J Xenon	0.33	0.15	0.12	0.13	0.07	0.07	0.07
10J Xenon	0.65	0.32	0.19	0.21	0.11	0.12	0.12
15J Xenon	0.9	0.43	0.22	0.25	0.14	0.16	0.14
Filament - 60W	2.5	1.25	0.55	0.5	0.26	0.25	-
LED - Steady	0.22	0.12	0.07	0.07	0.04	0.04	0.04
LED - Flashing	0.42	0.22	0.09	0.09	0.05	0.05	0.05

* For 60Hz please refer to the US datasheet

Light output (effective Cd):

5J Xenon	10J Xenon	15J Xenon	Filament 60W	LED - Steady	LED - Flashing (60fpm)
107	280	382	64	86	128

Multiplying factor for coloured lenses

	Red	Blue	Green	Amber	Clear	Yellow
Xenon/filament	0.12	0.11	0.29	0.22	1	0.74
LED	0.47	0.19	0.67	0.43	1	0.95

Ordering requirements

The following code is designed to help in selection of the correct unit. Build up the reference number by inserting the code for each component into the appropriate box

Model	Certification	Lamp type/positions				Voltage	Cable entries	Lens guard	Duty/tag	Finish
SL15		V	W	X	Y					
	Certification Code ATEX B IECEX J					Voltage Code 24V d.c. 024 48V d.c. 048 110V a.c. 110 120V a.c. 120 230V a.c. 230 240V a.c. 240 254V a.c. 254		Guard Code None N Cast C Wire W		Finish Code Natural black N Red R Blue B Yellow Y Green G White W Special S*
		Indicate light module type Filament Xenon LED - 6* Xenon Xenon 60W - 1† 15J 60fpm - 3 10J 60fpm - 7 5J 60fpm - 10 15J 80fpm - 4 10J 80fpm - 8 5J 80fpm - 11 15J 120fpm - 5 10J 120fpm - 9 5J 120fpm - 12				Entry Size Code M20 *C M25 *D		Label Code Duty label D* Tag label T* None N		
		Suffixed by colour required Lens colour Code Red R Blue B Green G Amber A Yellow Y Clear C				*Prefix with cable entry position (see diagram) Note: maximum 2 entries bottom OR top Bottom AND top entry(s) by special order only		*Please specify		

*User selectable function preset at 60fpm
†Not available 254Vdc

Example: A two way ATEX approved unit with one 60W filament lamp with green lens for the top unit and one 15J 60fpm xenon lamp with red lens for the bottom unit, rated 24V with 2 x M20 bottom entries, no guard, no labels, finished in red would be:
SL15B1G3R0242C3CNNR