

# SM87HXB 5 joule xenon and SM87LED high intensity LED beacon range

Ex d, weatherproof



## Overview

These certified beacons have been designed for use in harsh environmental conditions. The stainless steel or marine grade alloy enclosures are suitable for use offshore or onshore, where lightweight combined with corrosion resistance and strength is required. Units can be painted to customer specification and fitted with identification labels.

LED version available, offering extended lifetimes.

Stainless steel, one of the most durable materials available on the market, is both hard wearing and corrosion resistant, increasing the life of products in harsh environments and therefore reducing maintenance costs.

## Features

- Zone 1 and Zone 2 use
- Ex d IIC T4/T5/T6
- ATEX approved, Ex II 2GD
- IECEx certified Gb, Db
- UL listed for USA and Canada
  - Class I, Div 1, Groups C & D
  - Class I, Zone 1, AExd IIB
- CSA certified
- CQST certified\*
- INMETRO certified\*
- SIL 2 certified
- CCOE certified
- IP66 and IP67
- Certified temperature: -55°C to +70°C\*
- Stainless steel or marine grade alloy
- Xenon or LED versions
- Various lens colours
- Optional lens guard
- Telephone or relay initiated

\*Depending on version



### Authorised Distributor:



46, Jalan SS 22/21, Damansara Jaya,  
47400 Petaling Jaya,  
Selangor Darul Ehsan, Malaysia.  
Email: [ampmech@ampmech.com](mailto:ampmech@ampmech.com)  
Website: [www.ampmech.com](http://www.ampmech.com)

Eaton  
Unit B, Sutton Parkway  
Oddicroft Lane  
Sutton in Ashfield  
United Kingdom  
NG17 5FB

T: +44 (0) 1623 444 400  
[www.crouse-hinds.com/hac](http://www.crouse-hinds.com/hac)  
[MEDCSales@Eaton.com](mailto:MEDCSales@Eaton.com)

© 2024 Eaton  
All Rights Reserved  
Printed in UK  
Publication  
No.DSMC0041/F  
March 2024

Eaton is a registered trademark.

All other trademarks are property of their respective owners.



Powering Business Worldwide

## Certifications

<b>ATEX Ex d</b>	Cert. no. Baseefa 03ATEX0222 Certified to: EN60079-0, EN60079-1, EN60079-31 SM87HXB: Ex II 2GD, Ex d IIC T5/T6 Gb, Ex tb IIIC T65°C/T80°C/T95°C Db SM87LED: Ex II 2GD, Ex d IIC T6 Gb, Ex tb IIIC T55°C/T70°C Db
<b>IECEX Ex d</b>	Cert. no. IECEX BAS 09.0059 Certified to: IEC60079-0, IEC60079-1, IEC60079-31 SM87HXB: Ex d IIC T5/T6 Gb, Ex tb IIIC T65°C/T80°C/T95°C Db SM87LED: Ex d IIC T6 Gb, Ex tb IIIC T55°C/T70°C Db
<b>UL</b>	Listing no. E187894 Class I, Div 1, Groups C & D Class I, Zones 1. (SM87HXB & SM87XBT only)
<b>CSA</b>	Cert no. 96406. (SM87HXB only) Certified to: C22.2 Nos 0, 0.4, 0.5, 9, 30-M1986, 94-M91, 137-M1981 Class I, Div 1. Group D
<b>INMETRO Ex d</b>	SM87HXB: Ex db IIC T5/T6 Gb, Ex tb IIIC T80°C/T95°C Db SM87LED: Ex db IIC T6 Gb, Ex tb IIIC T70°C Db
<b>CQST Ex d</b>	SM87HXB: Ex d IIC T5/T6 Gb, Ex tb IIIC T65°C/T80°C/T95°C Db
<b>SIL</b>	SIL2 certification to IEC61508. Cert. No. 20151119-4786827453

## Specifications

<b>Material</b>	SM87HXBS and SM87LEDS: Grade 316 ANC4B stainless steel SM87HXBA and SM87LEDA: LM25 TF marine grade alloy Lens: glass UL version available only in marine grade alloy
<b>Finish</b>	Epoxy paint finish as standard
<b>Certified temp</b>	SM87HXB: ATEX, IECEX, CQST, INMETRO -55°C to +70°C (T5) -55°C to +55°C (T6) UL -55°C to +70°C CSA -50°C to +40°C SM87LED: ATEX, IECEX, CQST, INMETRO -55°C to +55°C* (T6) * Operating temperature is -20°C to +55°C
<b>Weight</b>	SM87HXBS & SM87LEDS: 3.8kg each (approx) SM87HXBA & SM87LEDA: 2kg. each (approx)
<b>Ingress protection</b>	IP66 & IP67
<b>Entries</b>	Up to 4 x M20 / M25 ISO or 1/2" / 3/4" NPT
<b>Terminals</b>	SM87HXB 6 off suitable for up to 1.5mm <sup>2</sup> cable SM87LED: 6 off suitable for up to 1.5mm <sup>2</sup> cable
<b>Relay initiate</b>	Initiation by telephone ringing tone or low voltage control signals
<b>Labels</b>	Duty & tag labels optional

## General arrangement drawing (all dimensions in mm)

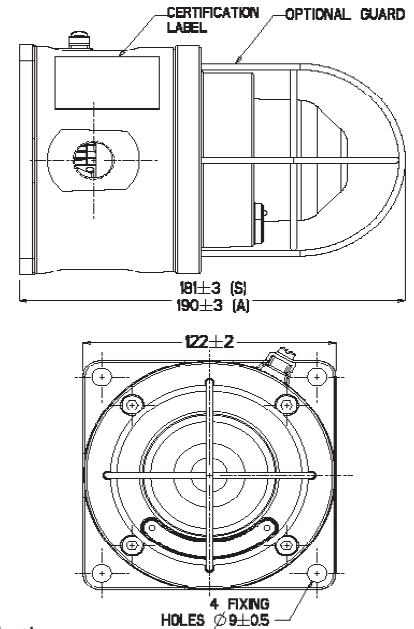

## Electrical ratings

	d.c.		a.c. 50/60Hz				
	24	48	110	120	220	240	254
<b>Voltage</b>	24	48	110	120	220	240	254
<b>Tube energy (Joules) SM87HXB</b>	5	5	6	7	6	7	8
<b>Current consumption SM87HXB</b>	393	175	250	275	120	135	153
<b>Current consumption SM87LED (mA)</b>	165	85	N/A	N/A	N/A	N/A	N/A
<b>Effective intensity (Cd)</b>	29	29	32	39	32	39	44
<b>Peak intensity (Cd)</b>	22213	22213	25061	30187	25061	30187	34174

NOTE: The above figures (Cd) are for a clear lens @ 1Hz flash rate

## Multiplying factor for coloured lenses

Red	Blue	Amber	Green	Yellow
0.15	0.12	0.51	0.49	0.86

The photometric data given above has been verified by BSI. Reports are available if required

## LED light output - steady or flashing (customer selectable)

	Red	Blue	Amber	Green
<b>Total LED output (candela)</b>	192	64	64	17

LED/lens colour: red, blue, green, amber, yellow (not LED) or clear  
Flash rate: 90fpm as standard, other flash rates available on request

## Ordering requirements

The following code is designed to help in selection of the correct unit. Build up the reference number by inserting the code for each component into the appropriate box

Model	Certification	Voltage	Lens/LED colour	Guard	Entries	Tag/duty	Options	Finish
<input type="text"/>	<input type="text"/>	<input type="text"/>	<input type="text"/>	<input type="text"/>	<input type="text"/>	<input type="text"/>	<input type="text"/>	<input type="text"/>
<b>Voltage</b> Xenon (stainless steel) SM87HXBS Xenon (alloy) SM87HXBA LED Exd (stainless steel) SM87LEDS LED Exd (alloy) SM87LEDA	<b>Certification</b> ATEX B IECEX J UL UL† CSA C‡ Chinese(CQST) Q INMETRO DM	<b>Voltage</b> 24 V d.c. 024 48 V d.c. 048 110 V a.c. not LED 110 120 V a.c. not LED 120 220 V a.c. not LED 220 240 V a.c. not LED 240 254 V a.c. not LED 254	<b>Colour</b> Clear C Red R Blue B Green G Amber A Yellow (not LED) Y	<b>Guard</b> None N Yes Y	<b>Entries</b> M20 1 M25 2 1/2" NPT 3 3/4" NPT 4 Top *T Bottom *B RHS *R LHS *L	<b>Label</b> None N Yes Y* * Please specify wording (Note: 15 characters maximum)	<b>Options</b> Telephone T*‡ Relay R*‡ EOL resistor E*† None N * Not available on UL versions † Please specify ‡ For SM87LED please specify if steady or flashing is required	<b>Colour</b> Red R Blue B Yellow Y Yellow/black stripe X Grey G White W Special S* *Please specify
† Only SM87HXBA is available UL certified ‡ Only SM87HXB								
* Prefix position with entry size code e.g. 1T1B=M20 Top and Bottom entries								