

# TH12 rotating beacon range

Ex d, weatherproof



## Overview

These certified rotating beacons have been designed for use in potentially explosive atmospheres and harsh environmental conditions. The enclosures are suitable for use offshore or onshore, where lightweight combined with corrosion resistance is required. The housing is manufactured completely from a UV stable, glass reinforced polyester. Stainless steel screws and mounting bracket are available ensuring a totally corrosion free product. Units can be painted to customer specification and supplied with identification labels.

## Features

- Zone 1 and Zone 2 use
  - Exd, IIB T3 and T4
  - ATEX approved, Ex II 2G
  - BASEEFA certified
  - IECEx certified Gb
  - INMETRO certified
  - IP66 and IP67
  - Certified temperature: -55°C to +70°C
  - 55W and 70W tungsten halogen bulb\*
  - Various rotating speeds available
  - Corrosion resistant GRP
  - Optional stainless steel backstrap
  - Various lens colours
  - Optional lens guard
- \* Voltage dependent

### Authorised Distributor:



46, Jalan SS 22/21, Damansara Jaya,  
47400 Petaling Jaya,  
Selangor Darul Ehsan, Malaysia.  
Email: [ampmech@ampmech.com](mailto:ampmech@ampmech.com)  
Website: [www.ampmech.com](http://www.ampmech.com)



Powering Business Worldwide

Eaton  
Unit B, Sutton Parkway  
Oddicroft Lane  
Sutton in Ashfield  
United Kingdom  
NG17 5FB

T: +44 (0) 1623 444 400  
[www.crouse-hinds.com/hac](http://www.crouse-hinds.com/hac)  
[MEDCSales@Eaton.com](mailto:MEDCSales@Eaton.com)

© 2024 Eaton  
All Rights Reserved  
Printed in UK  
Publication  
No.DSMC0054/C  
March 2024

Eaton is a registered trademark.

All other trademarks are property  
of their respective owners.



Please check here  
for latest version of  
the datasheet

## Certifications

<b>ATEX Ex d</b>	Cert. no. BAS99ATEX2196 Certified to: EN60079-0, EN60079-1 Ex II 2G, Ex d IIB T3/T4 Gb
<b>IECEX Ex d</b>	Cert. no. IECEX BAS 10.0094 Certified to: IEC60079-0, IEC60079-1 Ex d IIB T3/T4 Gb
<b>INMETRO Ex d</b>	Ex d IIB T3/T4 Gb

## Specifications

<b>Material</b>	Body: glass reinforced polyester (GRP) Lens: glass Cover screws and backstrap: stainless steel 316
<b>Finish</b>	Natural black or painted to customer specification
<b>Bulb Life</b>	We do not recommend the continuous use of the TH12 for over 3 hours as this could adversely affect its life
<b>Bulb Type</b>	70 Watt H1 tungsten halogen bulb (24V) 55 Watt H1 tungsten halogen bulb (12V)
<b>Certified temp</b>	-55°C to +70°C (T3) -55°C to +55°C (T4)
<b>Operating temp</b>	-20°C to +70°C
<b>Weight</b>	7.6kg
<b>Ingress protection</b>	IP66 & IP67
<b>Entries</b>	2 x M20
<b>Terminals</b>	6 x 6.0mm <sup>2</sup>
<b>Labels</b>	Tag/duty label option

Wattage	55W	70W	70W	70W
<b>Voltage</b>	12Vdc	24Vdc	110Vac	240Vac
<b>Peak current</b>	4.85A	2.92A	0.64A	0.34A

Rotational speed (r.p.m.)	60	120	180
<b>Effective intensity (Cd)</b>	3354	1957	895
<b>Peak intensity (Cd)</b>	11164	11164	11164

Note: The above figures (Cd) are for a 70W lamp with clear lens  
Rotational speed may vary by ±20% of the stated r.p.m

### Multiplying factor for coloured lenses:

Red	Blue	Amber	Green	Yellow
0.12	0.11	0.29	0.22	0.74

The photometric data has been verified by BSI. A report is available if required

## General arrangement drawing (all dimensions in mm)

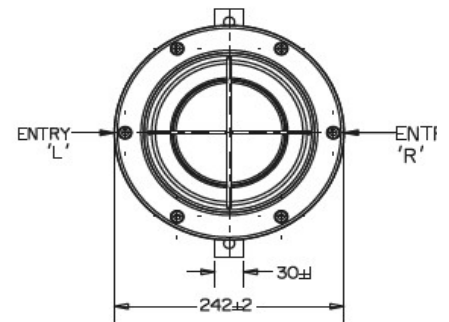
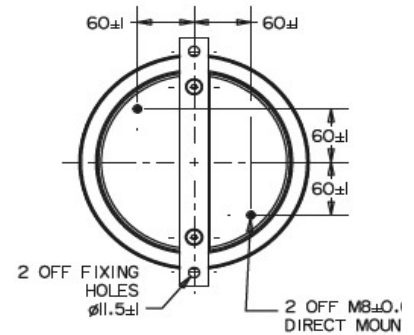
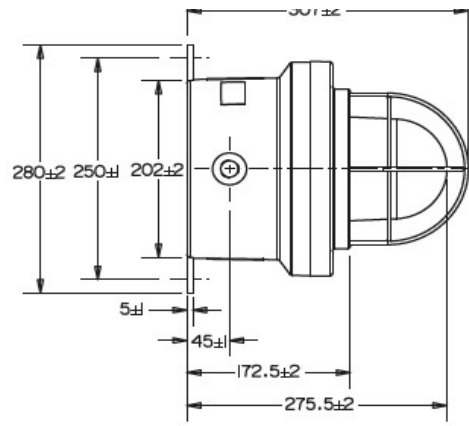

## Ordering requirements

The following code is designed to help in selection of the correct unit. Build up the reference number by inserting the code for each component into the appropriate box

Model	Certification	Speed	Voltage	Lens colour	Lens guard	Fixings	Options	Finish																																											
TH12																																																			
	<table border="1"> <thead> <tr> <th>Certification</th> <th>Code</th> </tr> </thead> <tbody> <tr> <td>ATEX</td> <td>B</td> </tr> <tr> <td>IECEX</td> <td>J</td> </tr> <tr> <td>INMETRO</td> <td>DM</td> </tr> </tbody> </table>	Certification	Code	ATEX	B	IECEX	J	INMETRO	DM		<table border="1"> <thead> <tr> <th>Voltage</th> <th>Code</th> </tr> </thead> <tbody> <tr> <td>12V d.c.</td> <td>012</td> </tr> <tr> <td>24V d.c.</td> <td>024†</td> </tr> <tr> <td>110V a.c.</td> <td>110†</td> </tr> <tr> <td>240V a.c.</td> <td>240†</td> </tr> </tbody> </table> <p>* 55W only available 12V d.c. † 70W only available 24V d.c., 110V a.c. &amp; 240V a.c</p>	Voltage	Code	12V d.c.	012	24V d.c.	024†	110V a.c.	110†	240V a.c.	240†		<table border="1"> <thead> <tr> <th>Guard</th> <th>Code</th> </tr> </thead> <tbody> <tr> <td>None</td> <td>N</td> </tr> <tr> <td>Yes</td> <td>Y</td> </tr> </tbody> </table>	Guard	Code	None	N	Yes	Y		<table border="1"> <thead> <tr> <th>Option</th> <th>Code</th> </tr> </thead> <tbody> <tr> <td>Tag label</td> <td>T*</td> </tr> <tr> <td>Duty label</td> <td>D*</td> </tr> <tr> <td>Earth continuity</td> <td>E</td> </tr> <tr> <td>None</td> <td>N</td> </tr> </tbody> </table> <p>*Please specify</p>	Option	Code	Tag label	T*	Duty label	D*	Earth continuity	E	None	N										
Certification	Code																																																		
ATEX	B																																																		
IECEX	J																																																		
INMETRO	DM																																																		
Voltage	Code																																																		
12V d.c.	012																																																		
24V d.c.	024†																																																		
110V a.c.	110†																																																		
240V a.c.	240†																																																		
Guard	Code																																																		
None	N																																																		
Yes	Y																																																		
Option	Code																																																		
Tag label	T*																																																		
Duty label	D*																																																		
Earth continuity	E																																																		
None	N																																																		
		<table border="1"> <thead> <tr> <th>Speed</th> <th>Code</th> </tr> </thead> <tbody> <tr> <td>60/min</td> <td>A</td> </tr> <tr> <td>120/min</td> <td>B</td> </tr> <tr> <td>180/min</td> <td>C*</td> </tr> </tbody> </table> <p>* Not available 110V a.c</p>	Speed	Code	60/min	A	120/min	B	180/min	C*	<table border="1"> <thead> <tr> <th>Lens colour</th> <th>Code</th> </tr> </thead> <tbody> <tr> <td>Red</td> <td>R</td> </tr> <tr> <td>Blue</td> <td>B</td> </tr> <tr> <td>Green</td> <td>G</td> </tr> <tr> <td>Amber</td> <td>A</td> </tr> <tr> <td>Yellow</td> <td>Y</td> </tr> <tr> <td>Clear</td> <td>C</td> </tr> </tbody> </table>	Lens colour	Code	Red	R	Blue	B	Green	G	Amber	A	Yellow	Y	Clear	C		<table border="1"> <thead> <tr> <th>Fixings</th> <th>Code</th> </tr> </thead> <tbody> <tr> <td>Direct mount without backstrap</td> <td>D</td> </tr> <tr> <td>Direct mount with backstrap</td> <td>B</td> </tr> </tbody> </table>	Fixings	Code	Direct mount without backstrap	D	Direct mount with backstrap	B		<table border="1"> <thead> <tr> <th>Finish</th> <th>Code</th> </tr> </thead> <tbody> <tr> <td>Natural black</td> <td>N</td> </tr> <tr> <td>Red</td> <td>R</td> </tr> <tr> <td>Blue</td> <td>B</td> </tr> <tr> <td>Yellow</td> <td>Y</td> </tr> <tr> <td>Grey</td> <td>G</td> </tr> <tr> <td>White</td> <td>W</td> </tr> <tr> <td>Special</td> <td>S*</td> </tr> </tbody> </table> <p>*Please specify</p>	Finish	Code	Natural black	N	Red	R	Blue	B	Yellow	Y	Grey	G	White	W	Special	S*
Speed	Code																																																		
60/min	A																																																		
120/min	B																																																		
180/min	C*																																																		
Lens colour	Code																																																		
Red	R																																																		
Blue	B																																																		
Green	G																																																		
Amber	A																																																		
Yellow	Y																																																		
Clear	C																																																		
Fixings	Code																																																		
Direct mount without backstrap	D																																																		
Direct mount with backstrap	B																																																		
Finish	Code																																																		
Natural black	N																																																		
Red	R																																																		
Blue	B																																																		
Yellow	Y																																																		
Grey	G																																																		
White	W																																																		
Special	S*																																																		