

XB4 21 joule xenon beacon range

Ex d(e), weatherproof



Overview

These high output (21 joule) beacons have been designed for use in potentially explosive atmospheres and harsh environmental conditions. The marine grade alloy or stainless steel enclosures are suitable for use offshore or onshore, where lightweight combined with corrosion resistance and strength is required.

Units can be painted to customer specification and fitted with identification labels. Stainless steel, one of the most durable materials available on the market, is both hard wearing and corrosion resistant, increasing the life of products in harsh environments and therefore reducing maintenance costs.

Features

- Zone 1 and Zone 2 use
- Ex d(e) IIC
- ATEX approved Ex II 2GD
- IECEx certified Gb,Db
- UL Listed for USA and Canada:
 - Hazardous locations:
 - Class I, Div 1, Groups C & D
 - Class I, Zone 1, AEx d IIB T4
 - Ordinary locations: visual-signal device
- PESO certified (Ex d only)
- Certified temperature -55°C to $+70^{\circ}\text{C}$ *
- IP67 and IP66
- Stainless steel or marine grade alloy
- Various lens colours
- Twin replaceable tubes
- Optional Ex e chamber
- Ex de version has gland earth continuity in the GRP terminal chamber
- Tapered spigot flamepath
- Telephone or relay initiated option
- Optional lens guard

*Model dependent



Authorised Distributor:



46, Jalan SS 22/21, Damansara Jaya,
47400 Petaling Jaya,
Selangor Darul Ehsan, Malaysia.
Email: ampmech@ampmech.com
Website: www.ampmech.com

Eaton
Unit B, Sutton Parkway
Oddicroft Lane
Sutton in Ashfield
United Kingdom
NG17 5FB

T: +44 (0) 1623 444 400
www.crouse-hinds.com/hac
MEDCSales@Eaton.com

© 2024 Eaton
All Rights Reserved
Printed in UK
Publication
No.DSMC0012/C
March 2024

Eaton is a registered trademark.

All other trademarks are property of their respective owners.



Powering Business Worldwide

Certifications

ATEX Ex d	Cert. no. Baseefa 02ATEX0224X Certified to: EN60079-0, EN60079-1, EN60079-31 Ex II 2GD, Ex d IIC T4/T5/T6 Gb. Ex tb IIIC T85°C/T100°C/T135°C Db
ATEX Ex de	Ex II 2G EEx de IIC
IECEX Ex d	Cert. no. IECEX BAS 10.0078X Certified to: IEC60079-0, IEC60079-1, IEC60079-31 Ex II 2GD, Ex d IIC T4/T5/T6 Gb. Ex tb IIIC T85°C/T100°C/T135°C Db
UL Haz Locs	Listing no. E187894 Class I, Div 1, Groups C & D Class I, Zone 1, AEx d IIB T4
UL Ord Locs	Listing no. S8128. Visual signal device

Specifications

Material	LM25TF marine grade alloy body Grade 316 ANC4B stainless steel body Glass reinforced polyester (GRP) terminal chamber Toughened wellglass
Finish	Epoxy paint finish as standard or to customer specification
Certified temp	UL -25°C to +70°C ATEX -50°C to +55°C (Ex de) ATEX, IECEX -55°C to +70°C (Ex d)
Weight	Ex d: 6.6kg. Ex de: 7.6kg. Add 8.4kg for stainless steel version
Entries	Up to 3 x M20 or 2 x M25 ISO in Exd unit Up to 4 x M20 or 4 x M25 ISO in Exe unit
Terminals	Exe: 6 off suitable for up to 6mm ² cable Exd: 8 off suitable for up to 6mm ² cable
Telephone initiation or relay interface	Initiation by telephone ringing tone or low voltage control signals, plus initiation of a second beacon or sounder
Tube life	>1x10 ⁸ flashes

General arrangement drawing (all dimensions in mm)

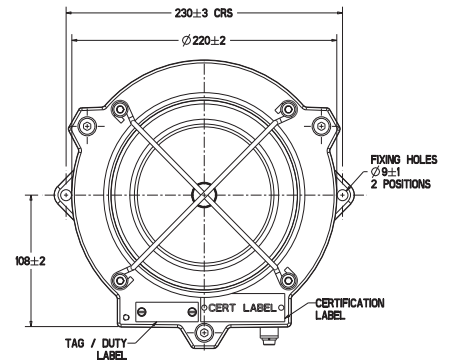
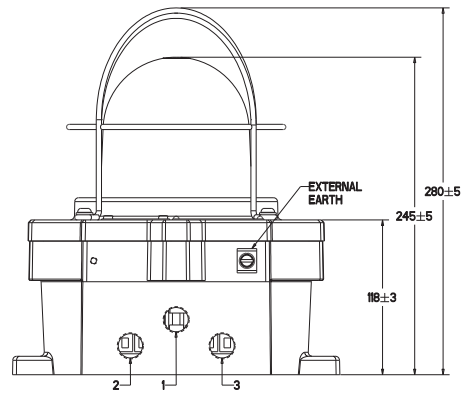

Electrical ratings:

	dc	ac 50/60/Hz	
Voltage	24	110	240
Tube energy (joules)	21	21	21
Current (mA)	1400	350	185
Effective intensity (Cd)	355	355	355
Peak intensity (Cd)	123691	123691	123691

Note: The above figures (Cd) are for a clear lens @ 1Hz flash rate

Multiplying factor for coloured lenses:

Red	Blue	Amber	Green	Yellow
0.15	0.12	0.51	0.49	0.86

The photometric data given above has been verified by BSI Reports are available if required

Ordering requirements

The following code is designed to help in selection of the correct unit. Build up the reference number by inserting the code for each component into the appropriate box

Model	Certification	Voltage	Terminals	Entries	Flashrate	Options	Guard	Lens colour	Tag/duty	Material	Finish																																																										
XB4																																																																					
<table border="1"> <thead> <tr> <th>Certification</th> <th>Code</th> </tr> </thead> <tbody> <tr> <td>ATEX</td> <td>B</td> </tr> <tr> <td>IECEX</td> <td>J</td> </tr> <tr> <td>UL</td> <td>UL*</td> </tr> <tr> <td>UL (ordinary locations)</td> <td>UW</td> </tr> </tbody> </table> <p>* UL - available alloy or stainless steel - 24v d.c., 110v a.c., - 240v a.c. only</p>		Certification	Code	ATEX	B	IECEX	J	UL	UL*	UL (ordinary locations)	UW	<table border="1"> <thead> <tr> <th>Terminals</th> <th>Code</th> </tr> </thead> <tbody> <tr> <td>6 x 6mm² (Ex de)</td> <td>6E*</td> </tr> <tr> <td>8 x 6mm² (Ex d)</td> <td>8D</td> </tr> </tbody> </table> <p>*IECEX and UL not available in Ex de</p>		Terminals	Code	6 x 6mm ² (Ex de)	6E*	8 x 6mm ² (Ex d)	8D	<table border="1"> <thead> <tr> <th>Flashrate</th> <th>Code</th> </tr> </thead> <tbody> <tr> <td>60 / min</td> <td>06</td> </tr> <tr> <td>120 / min</td> <td>12</td> </tr> </tbody> </table>		Flashrate	Code	60 / min	06	120 / min	12	<table border="1"> <thead> <tr> <th>Guard</th> <th>Code</th> </tr> </thead> <tbody> <tr> <td>None</td> <td>N</td> </tr> <tr> <td>Yes</td> <td>Y</td> </tr> </tbody> </table>		Guard	Code	None	N	Yes	Y	<table border="1"> <thead> <tr> <th>Label</th> <th>Code</th> </tr> </thead> <tbody> <tr> <td>None</td> <td>N</td> </tr> <tr> <td>Yes</td> <td>Y*</td> </tr> </tbody> </table> <p>*Please specify</p>		Label	Code	None	N	Yes	Y*	<table border="1"> <thead> <tr> <th>Finish</th> <th>Code</th> </tr> </thead> <tbody> <tr> <td>Red</td> <td>R</td> </tr> <tr> <td>Blue</td> <td>B</td> </tr> <tr> <td>Yellow</td> <td>Y</td> </tr> <tr> <td>Grey</td> <td>G</td> </tr> <tr> <td>White</td> <td>W</td> </tr> <tr> <td>Other</td> <td>S*</td> </tr> </tbody> </table> <p>*Please specify</p>		Finish	Code	Red	R	Blue	B	Yellow	Y	Grey	G	White	W	Other	S*										
Certification	Code																																																																				
ATEX	B																																																																				
IECEX	J																																																																				
UL	UL*																																																																				
UL (ordinary locations)	UW																																																																				
Terminals	Code																																																																				
6 x 6mm ² (Ex de)	6E*																																																																				
8 x 6mm ² (Ex d)	8D																																																																				
Flashrate	Code																																																																				
60 / min	06																																																																				
120 / min	12																																																																				
Guard	Code																																																																				
None	N																																																																				
Yes	Y																																																																				
Label	Code																																																																				
None	N																																																																				
Yes	Y*																																																																				
Finish	Code																																																																				
Red	R																																																																				
Blue	B																																																																				
Yellow	Y																																																																				
Grey	G																																																																				
White	W																																																																				
Other	S*																																																																				
<table border="1"> <thead> <tr> <th>Voltage</th> <th>Code</th> </tr> </thead> <tbody> <tr> <td>24Vdc</td> <td>B</td> </tr> <tr> <td>48Vdc</td> <td>C</td> </tr> <tr> <td>110Vdc</td> <td>D</td> </tr> <tr> <td>110Vac</td> <td>E</td> </tr> <tr> <td>120Vac</td> <td>F</td> </tr> <tr> <td>220Vac</td> <td>G</td> </tr> <tr> <td>240Vac</td> <td>H</td> </tr> <tr> <td>254Vac</td> <td>J</td> </tr> </tbody> </table>		Voltage	Code	24Vdc	B	48Vdc	C	110Vdc	D	110Vac	E	120Vac	F	220Vac	G	240Vac	H	254Vac	J	<table border="1"> <thead> <tr> <th>Entries</th> <th>Code</th> </tr> </thead> <tbody> <tr> <td>M20</td> <td>*B</td> </tr> <tr> <td>M25</td> <td>*C</td> </tr> <tr> <td>½" NPT</td> <td>*D</td> </tr> <tr> <td>¾" NPT</td> <td>*E</td> </tr> </tbody> </table> <p>*Prefix entry size (see diagram above) with entry position code e.g 2B3B</p>		Entries	Code	M20	*B	M25	*C	½" NPT	*D	¾" NPT	*E	<table border="1"> <thead> <tr> <th>Options</th> <th>Code</th> </tr> </thead> <tbody> <tr> <td>None</td> <td>A</td> </tr> <tr> <td>Telephone</td> <td>B</td> </tr> <tr> <td>Telephone & 2nd beacon/sounder</td> <td>C</td> </tr> <tr> <td>Relay (12-48Vac/dc)</td> <td>D*</td> </tr> <tr> <td>Relay (12-48Vac/dc) & 2nd beacon/sounder</td> <td>E*</td> </tr> </tbody> </table> <p>*Please specify ac/dc voltage</p>		Options	Code	None	A	Telephone	B	Telephone & 2nd beacon/sounder	C	Relay (12-48Vac/dc)	D*	Relay (12-48Vac/dc) & 2nd beacon/sounder	E*	<table border="1"> <thead> <tr> <th>Lens</th> <th>Code</th> </tr> </thead> <tbody> <tr> <td>Red</td> <td>R</td> </tr> <tr> <td>Blue</td> <td>B</td> </tr> <tr> <td>Green</td> <td>G</td> </tr> <tr> <td>Yellow</td> <td>Y</td> </tr> <tr> <td>Amber</td> <td>A</td> </tr> <tr> <td>Clear</td> <td>C</td> </tr> </tbody> </table>		Lens	Code	Red	R	Blue	B	Green	G	Yellow	Y	Amber	A	Clear	C	<table border="1"> <thead> <tr> <th>Material</th> <th>Code</th> </tr> </thead> <tbody> <tr> <td>Alloy</td> <td>1</td> </tr> <tr> <td>Stainless steel</td> <td>0</td> </tr> </tbody> </table>		Material	Code	Alloy	1	Stainless steel	0
Voltage	Code																																																																				
24Vdc	B																																																																				
48Vdc	C																																																																				
110Vdc	D																																																																				
110Vac	E																																																																				
120Vac	F																																																																				
220Vac	G																																																																				
240Vac	H																																																																				
254Vac	J																																																																				
Entries	Code																																																																				
M20	*B																																																																				
M25	*C																																																																				
½" NPT	*D																																																																				
¾" NPT	*E																																																																				
Options	Code																																																																				
None	A																																																																				
Telephone	B																																																																				
Telephone & 2nd beacon/sounder	C																																																																				
Relay (12-48Vac/dc)	D*																																																																				
Relay (12-48Vac/dc) & 2nd beacon/sounder	E*																																																																				
Lens	Code																																																																				
Red	R																																																																				
Blue	B																																																																				
Green	G																																																																				
Yellow	Y																																																																				
Amber	A																																																																				
Clear	C																																																																				
Material	Code																																																																				
Alloy	1																																																																				
Stainless steel	0																																																																				