

Industry Killer Applications

Refinery



Metal & Mining



Chemical



Upstream Oil & Gas



The Right Technology for Level Applications

Differential pressure and hydrostatic

For liquid tank levels including wide temperature and pressure requirements

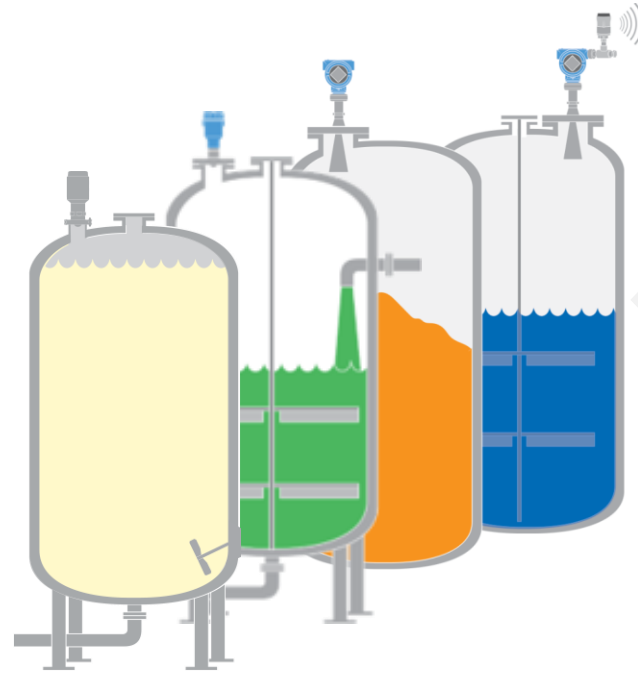
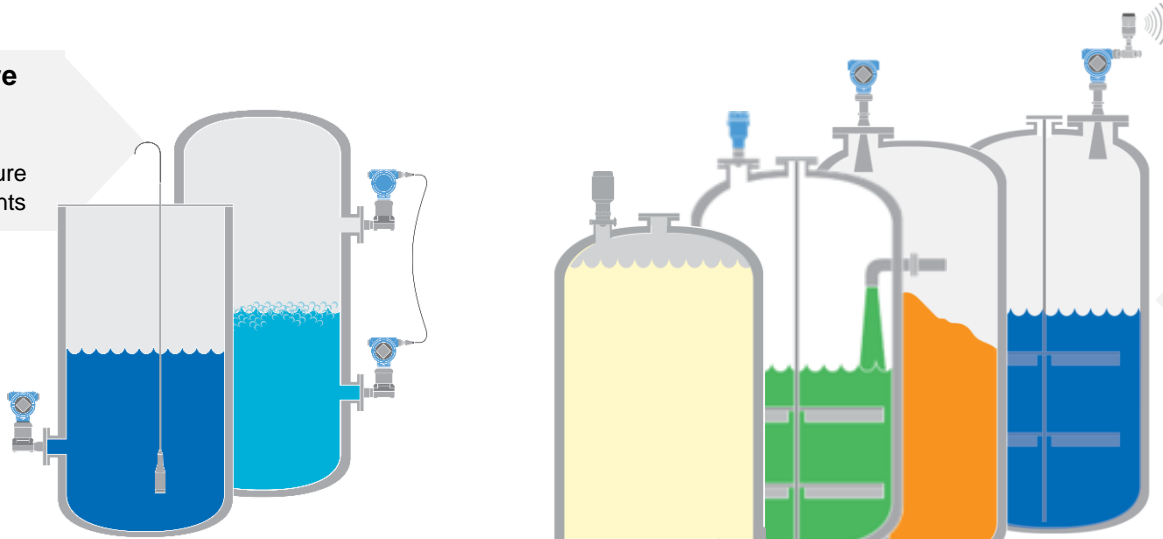

Non-Contacting Radar

For liquid and solid tank levels including wide temperature and pressure requirements

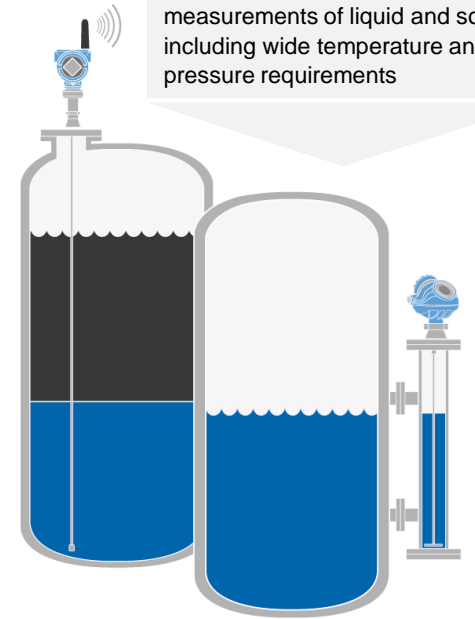

Guided Wave Radar

For level and interface measurements of liquid and solids including wide temperature and pressure requirements

Solids Measurement

Point and continuous measurement, suitable for small to very large silos

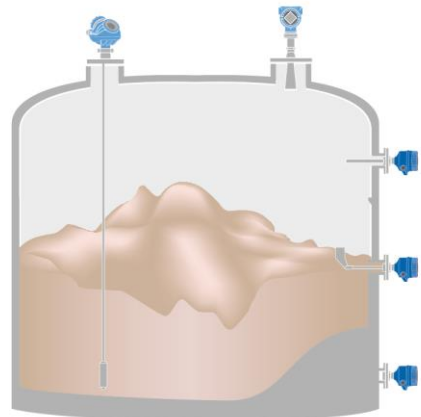

Point Level Detection

For high and low liquid level alarms, overflow prevention, and pump protection

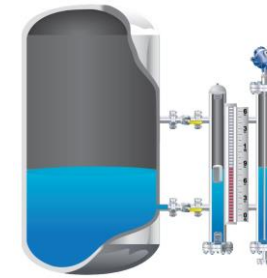
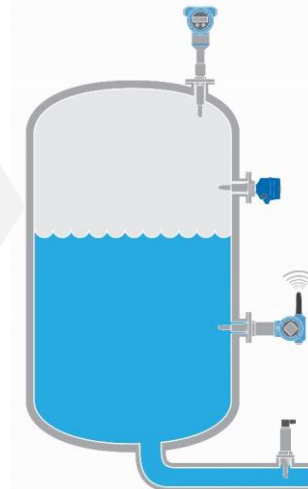

MagTech - MLI

For liquid tank levels including wide temperature and pressure requirements

Inventory Tank Gauging

Highly accurate measurement data, and real time inventory calculations in bulk liquid storage tanks

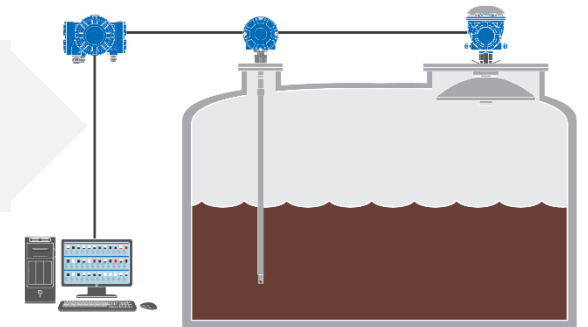

Chemical Killer Application



Mixing Tanks and Reactors

Challenges

Quickly changing levels and temperatures, turbulence, viscous or corrosive media and foam.

Solution

Non-contacting radars are ideal for level measurement in these applications with agitators and to avoid direct contact with the media.

Rosemount™ 3408 Level Transmitter with PVDF process seal antenna for corrosive chemicals has Bluetooth® connectivity for easy access to the device.

Rosemount™ 5408 Level Transmitter with its lower frequency can handle tough reactor conditions with steam, high turbulence and foam.

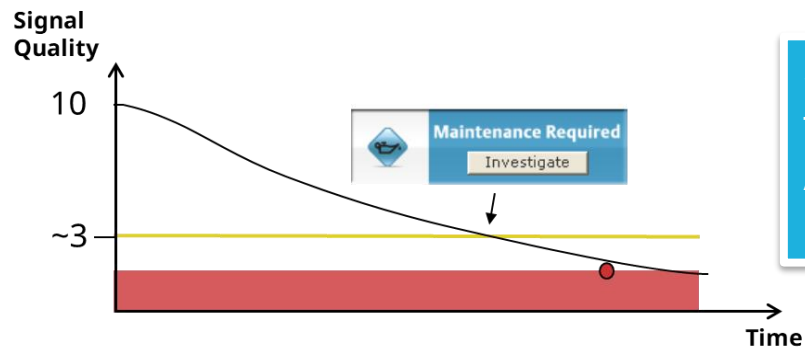

Signal Quality Metrics detects both foam and build-up
Alarm → Preventive maintenance →
Less downtime

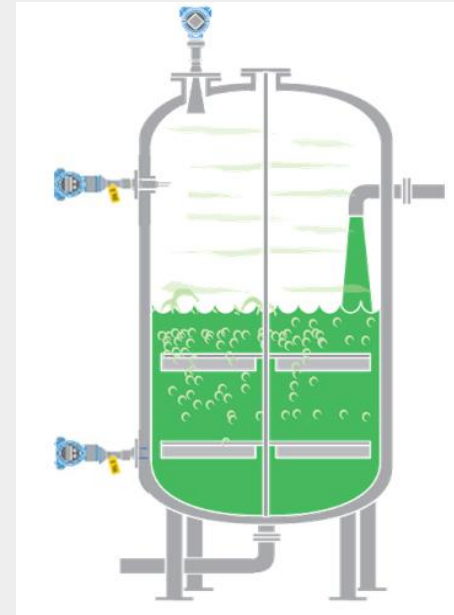
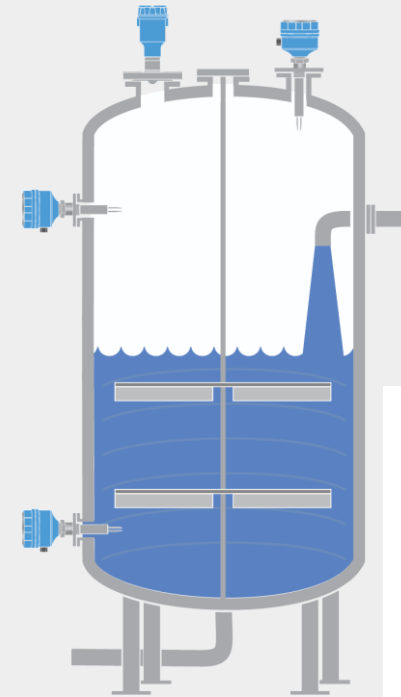

Application

Level Measurement of lye/soap mix in a mixing tank



Challenging Level Measurement Application Solved with Rosemount™ 5408 Level Transmitter

Challenge

- Challenging measurement environment: 18m high tanks containing black liquor (mix of lye and soap)
- Aggressive media with thick foam layer and coating properties
- Previous trials of various level technologies failed due to build up and errors due to narrow nozzle

Solution

- Rosemount 5408 with 3" process seal antenna installed, integrated into customer Sodra's DCS system
- SQM function utilized to detect abnormal conditions such as build-up and foam

Result

- Non-contacting FMCW technology provided higher sensitivity to penetrate foam
- Reliable measurement, even in turbulent conditions
- Downtime and maintenance reduced



Chemical Storage - IBC Containers and Plastic Tanks

Application

Plastic tanks and IBC containers are often used to store chemicals.

Challenge

No tank connection for a level measurement and corrosive or toxic media. Limited space to place sensor.

Solution

Radar waves easily penetrate the plastic tank roof → the level sensor is not in contact with the media → no need for a tank connection.

The **Rosemount™ 1208** Level and Flow Transmitter has a compact form which makes it suitable for installation in space-limited applications.

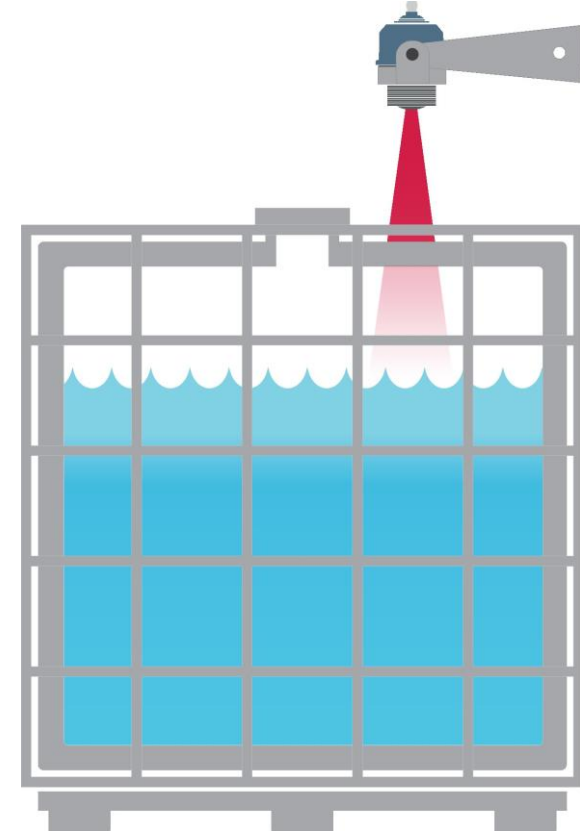

Utilities– Steam Systems

Reliable control and fail-safe limits of high and low water level in the steam vessels are crucial for safe operation of the steam system. It can be a challenge to measure level accurately and reliably in high pressure saturated steam applications. Disturbances in the steam system can lead to shutdowns or damage of turbine driven pumps or compressors

The **Rosemount™ 5300** Guided Wave Radar Level Transmitter with Dynamic Vapor Compensation can reduce the measuring error down to 2%

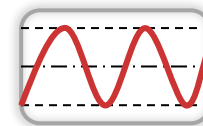
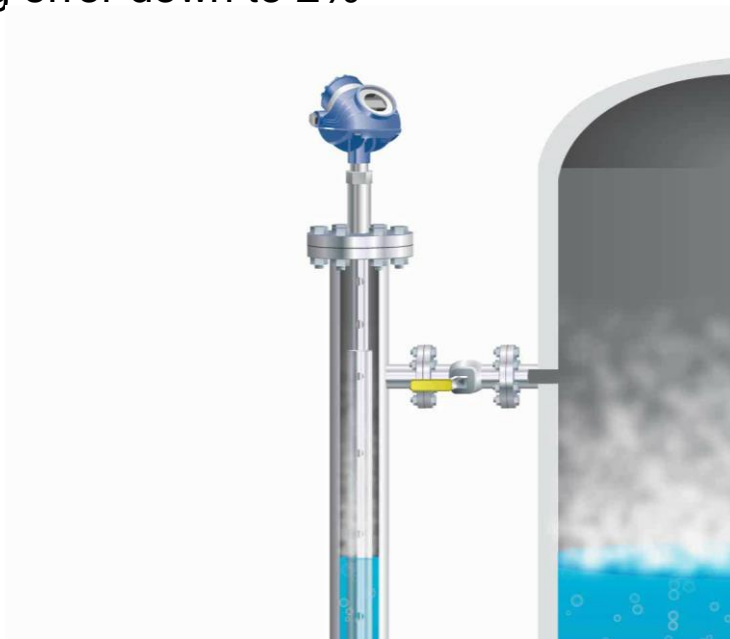

Density based level with no compensation *up to 30% error*

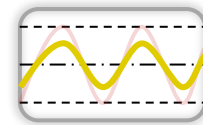

Guided Wave Radar with no compensation *up to 20% error*

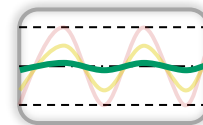

Rosemount 5300 with Dynamic Vapor Compensation *down to 2% error*

Application

Boiler drum level control at a combined cycle gas power plant



Major USA Power Plant Achieves Reliable Boiler Drum Level Control

Challenge

- Sub-freezing temperatures caused wet legs to freeze even though they were insulated and heat traced
- Instrumentation (differential pressure transmitters) indicated wrong drum levels, resulting in unit trips

Solution

- Rosemount 5300 Level Transmitter with Dynamic Vapor Compensation in a Level Bypass Chamber

Result

- Significantly increased unit reliability
- Accurate level readings during start-up and shut-down, regardless of the weather
- The plant is now working to implement the solution as a best practice for the combined cycle fleet



Refinery Killer Application



Distillation Column

– Hydrocarbons Separation by Boiling Point

Application Critical

- **Safety:** Overfill protection is crucial, see BP refinery incident where root cause was a wrong calibrated mechanical device.
- Highest possible product throughput for energy and cost-effective operation of the plant.
- Pump protection

Process Characteristics

- Medium: Hydrocarbon
- Pressure: -15 to 50 psi (-1 to 3.5 bar)
- Temperature: -58 to 932°F (-50–500 °C)

Challenges: Build-up and high or low temperatures

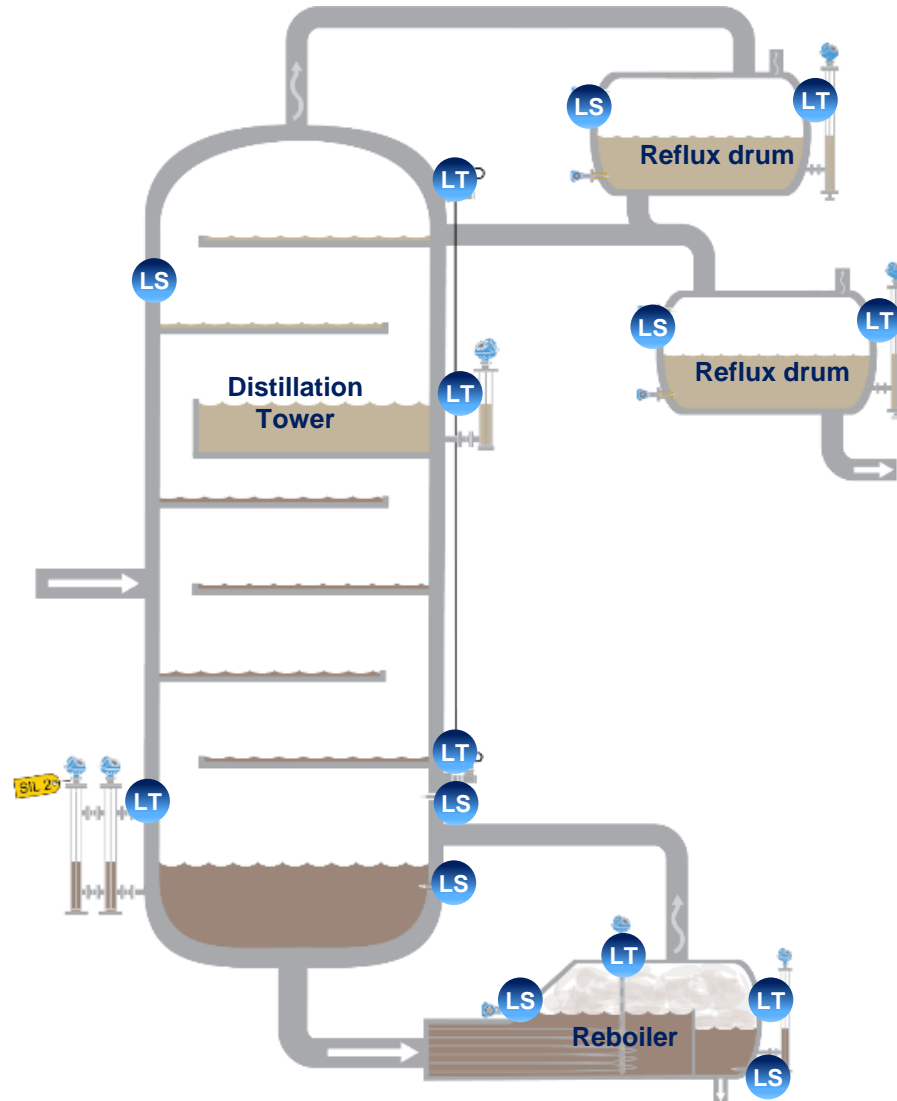

Videos:

[Video: BP Texas City Explosion](#)

[Video: ExxonMobil Refinery Explosion](#)

LT = Level Transmitter

LS = Level Switch

Fractionator Column Bottom and Trays

Application Criticality

- Highest possible product throughput for energy and cost-effective operation of the plant
- Separation of hydrocarbon

Process Characteristics

- Medium: Hydrocarbon
- Pressure: -15 to 50 psi (-1 to 3.5 bar)
- Temperature: -58 to 932°F (-50 to 500 °C)

Challenges: Build-up and high temperatures

Bypass vs Direct

- Some users may prefer to measure the level directly in the tower while others may prefer the serviceability of cages with valves
- If direct measurements are required, DP level is an appropriate solution
- If a bypass chamber is used, GWR is best practice
- Installation of DP level gives a potential leakage compared with top-down GWR

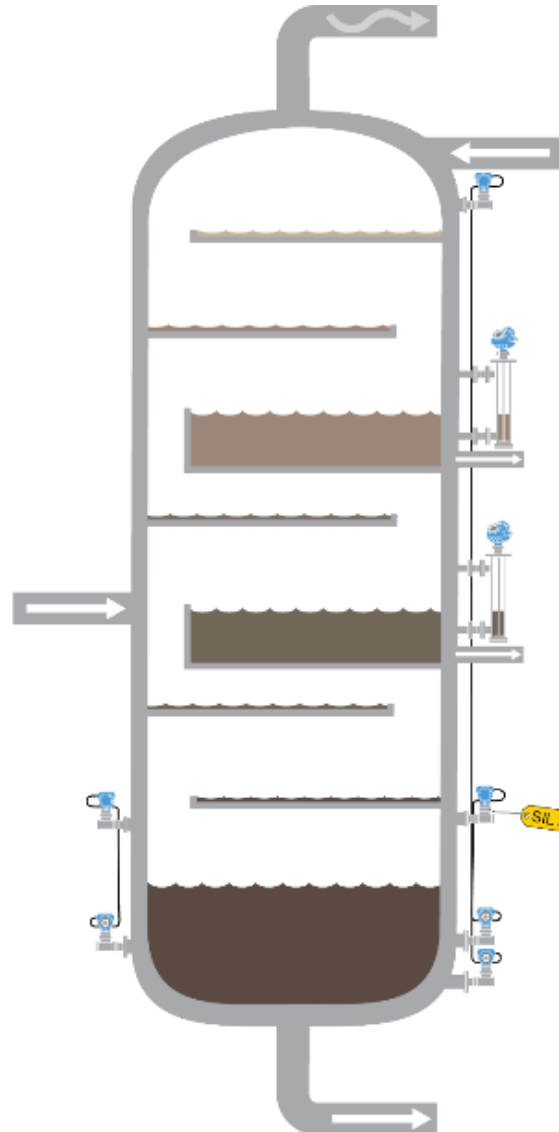

Rosemount 5301

- **Signal Quality Metric (SQM)**, to monitor signal strength and detect build-up
- **Probe End Projection (PEP)** to increase reliability with boiling hydrocarbon

Rosemount Chamber

- Chamber when measurement need to be isolated

Rosemount 3051S ERS,

- Differential Pressure Level with Thermal Range Expander
- Enables transmitters to attach to high temperature processes to extend the thermal operating range and improve response time

Rosemount 2140

- Frequency monitoring, to monitor media build-up
- Remote Proof Testing, to test device in situ



Re-boiler - Rosemount 5301 Dynamic Vapor Compensation (DVC) Saturated Steam Applications

Application Criticality

- **Reliability:** Heat exchanges are the 2nd largest reason for slowdown / shutdown in refining industry
- **Energy efficiency:** Accurate control of the level in the heat exchanger ensures energy efficient operation of the distillation with the right quality at the top of the column
- **Safety:** A reliable measurement ensures that the heating coils are always covered with liquid, to prevent any overheating incidents

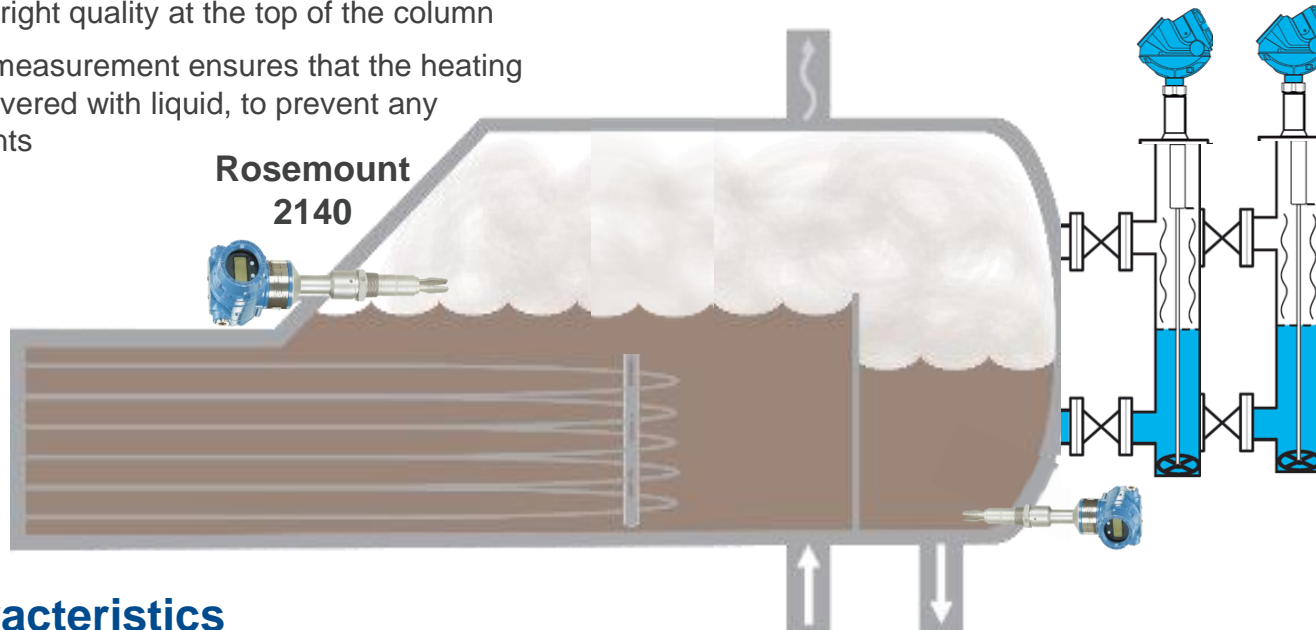

Process Characteristics

- Medium: Hydrocarbon
- Pressure: 145 – 500 psi (10 to 35 bar)
- Temperature: 302-752°F (150-400 °C)

Challenges: Extreme temperatures



Rosemount 5302

- Dynamic Vapor Compensation (DVC),

Rosemount Chamber

- Chamber when measurement need to be isolated

Rosemount 2140

- Frequency monitoring, to monitor media build-up
- Remote Proof Testing, to test device in situ



Reflux drum - Rosemount 5301 Single Ridged Probe

Application Criticality

- Reflux refers to the portion of the overhead liquid product from a distillation column that is returned to the upper part of the column.
- Inside the column, the downflowing reflux liquid provides cooling and condensation of the up flowing vapors, thereby increasing the efficiency of the distillation column

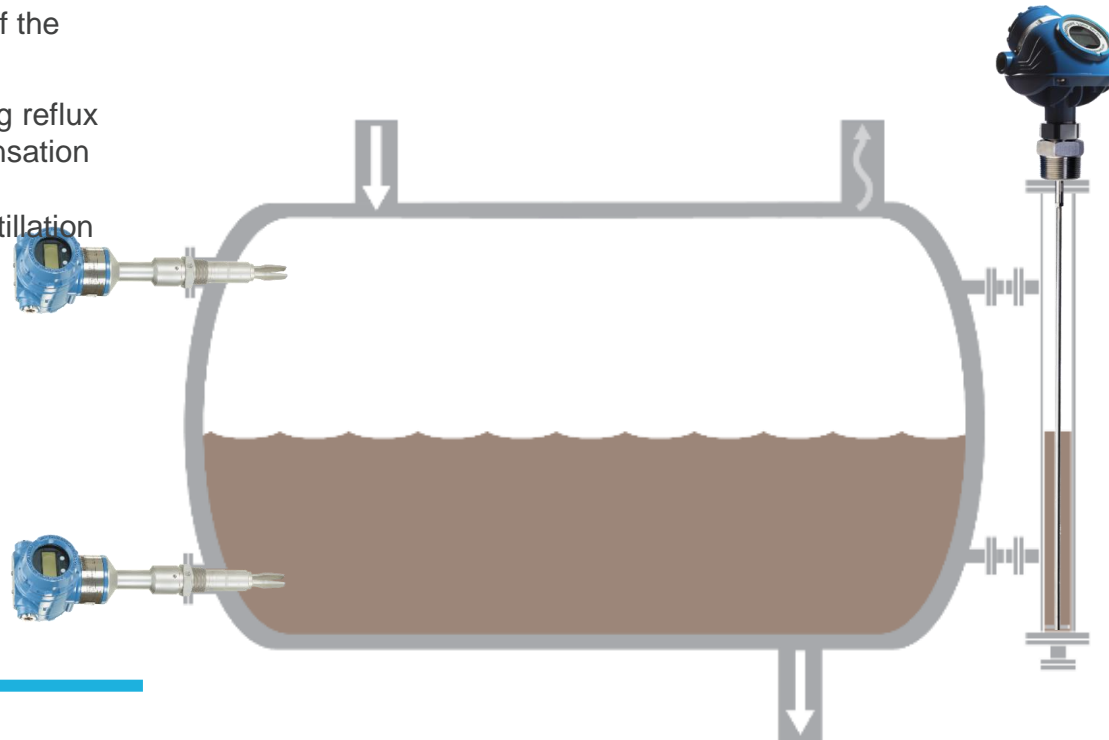

Process Characteristics

- Medium: Hydrocarbon
- Pressure: -15 to 50 psi (-1 to 3.5 bar)
- Temperature: -58 to 752°F (-50 – 400 °C)

Challenges: Buildup and high temperatures

Rosemount 5301

- **Signal Quality Metric (SQM)**, to monitor signal strength and detect build-up
- **Probe End Projection (PEP)** to increase reliability of measurement

Rosemount Chamber

- Chamber when measurement need to be isolated

Rosemount 2140

- **Frequency monitoring**, to monitor media build-up
- **Remote Proof Testing**, to test device in situ



Oil & Gas Killer Application



3 Phase Separators Level Control and ESD

Application Criticality

- Gas with acceptable liquid content (liquid carryover)
- Hydrocarbon with acceptable water content (water carryover)
- Water with acceptable hydrocarbon liquid content (oil carryover)
- Prevent carry under (gas phase in liquid phase)

Process Characteristics

- HP/ IP/ LP Production Separators
- Test Separators

Challenges: Changing Media density , can have sand , wax and other contaminant , high amount of H2S

Best Practice

- Install Interface Level measurement away from Inlet/outlet and closer to the weir/baffle plate
- Single rigid probe best suited on chamber installation

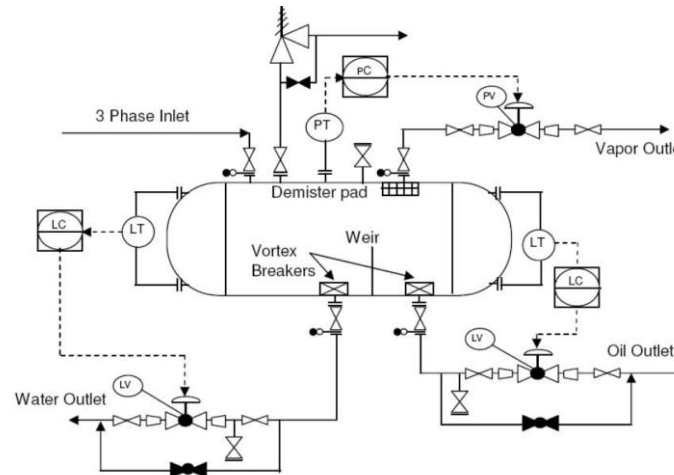
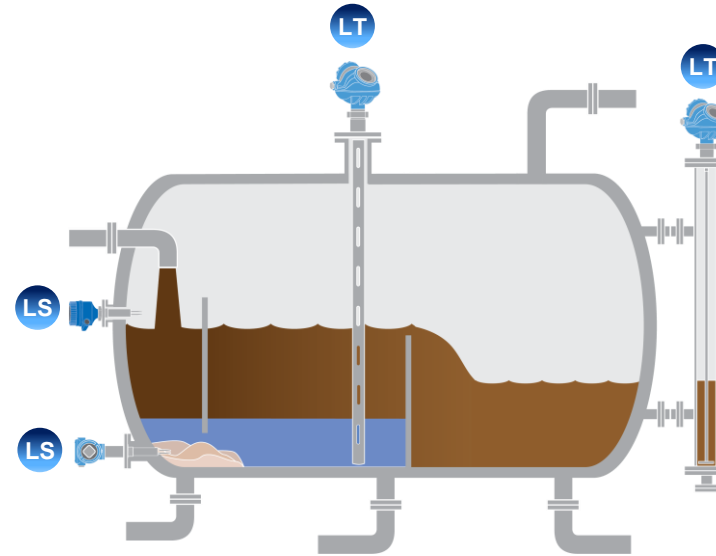

Rosemount 5300 GWR (Level & Interface)

- Continuous monitoring and predictive alert in case of coating on probe and special algorithm to track very thin layer interface layer

Rosemount Chamber

- Chamber when measurement need to be isolated. Always use GWR

Rosemount 5408/3408 (Gross Level)

- Direct tank installation with or without full bore ball valve
- Non Contact , hence least affected by media buildup/ coating
- Predictive alert incase of buildup on antenna

Rosemount 2100

- Monitor sediment built up (model 2140)
- High/Low Level detection (model 2120/2130)
- Remote Proof Testing, to test device in situ

Rosemount 9930 MLI (Sight Glass replacement)

- Enhance Safety
- Increased Visibility
- Minimize maintenance



Gas Scrubber / compressor suction scrubber Level Control and ESD

Application Criticality

- Remove liquid and particulate carryover to compressor
- Protects compressors and other downstream equipment from unwanted corrosion, erosion, wear and tear

Process Characteristics

- Multiple stages handle wide range of pressure condition

Measurement Challenges: non homogenous mix of water and various hydrocarbon (varying density) including thin layer of hydrocarbon over water

Best Practice

- Single probe or large coax probe best suited
- General practice is to install on bypass chamber.
- Chamber size shall be minimum 3 inch with 2 inch process connection
- GWR is the preferred technology for Chamber mounted continuous level measurement
- GWR shall be capable to detecting gross level even with condition of low density non homogenous layer of hydrocarbon over high density media such as water

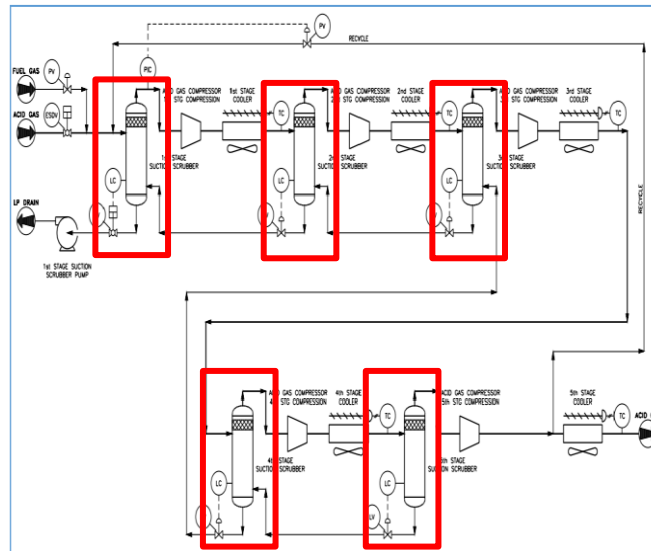
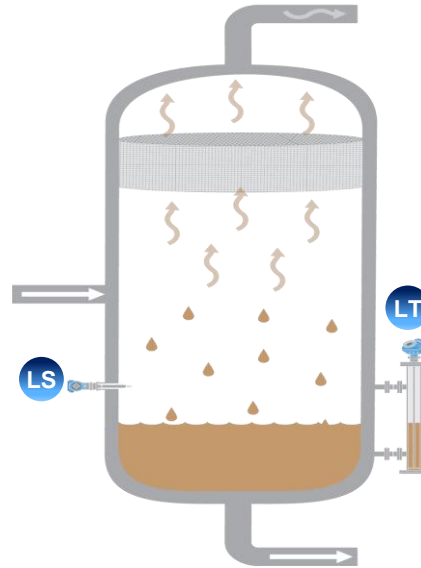

Rosemount 5300 GWR (Control and ESD)

- Continuous monitoring and predictive alert in case of coating on probe and special algorithm to track gross level even with low DC thin interface layer
- Single rigid probe, Best suited for Chamber installation
- Large Coax: Zero Dead band, overflow safe, can measure all the way upto radar flange

Rosemount 2100

- High/Low Level detection (model 2120/2130)
- Remote Proof Testing, to test device in situ (2140)

Rosemount Chamber

- For chamber installation, when Level measurement need to be isolated without taking the vessel out of service

Rosemount 9930 MLI (Sight Glass replacement)

- Enhance Safety
- Increased Visibility
- Minimize maintenance



Glycol Contactor/ Absorber Rich TEG Level Control and ESD

Application Criticality

- Liquid water and natural gas can form hydrates that may plug the pipeline and other equipment.
- Natural gas containing CO₂ and/or H₂S is corrosive when liquid water is present.
- Liquid water in a natural gas pipeline potentially causes slugging flow conditions resulting in lower flow efficiency of the pipeline.
- Water content decreases the heating value of natural gas being transported.

Process Characteristics

- High pressure , low temp process
Operating pressure 550 to 1200 psi(34barg- 83barg)
- Removes 90-95 percent H₂O in gas stream

Measurement Challenges: Mixture of TEG , water and various hydrocarbon water. Foam may be present.

Best Practice

- Single probe or large coax probe best suited
- General practice is to install on bypass chamber.
- Chamber size shall be minimum 3 inch with 2 inch process connection
- GWR is the preferred technology for Chamber mounted continues level measurement
- **GWR advance diagnostic (foam)helps predict nonperformance of upstream/downstream process equipment such as filter/strainer , inlet scrubber , etc**

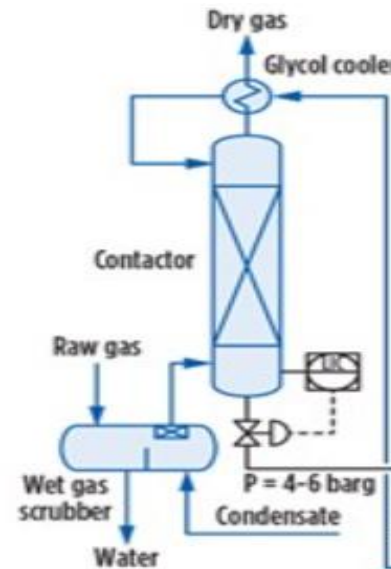
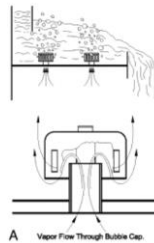
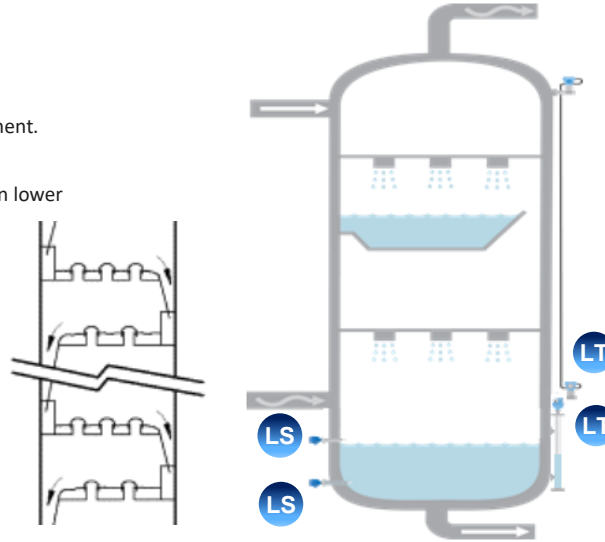

Rosemount 5300 GWR (Control and ESD)

- Continuous monitoring and predictive alert incase of coating on probe or foaming (indicates nonperformance of inlet scrubber / filter/ strainers)
- Large Coax: Zero Deadband , overfill safe , can measure all the way upto radar flange



Rosemount Chamber

- Chamber when measurement need to be isolated



Rosemount Electronic Seals (column differential pressure)

- No capillary , no fill fluid ,No ambient temp effect
- Maintenance free



Rosemount 2100

- High/Low Level detection (model 2120/2130)
- Remote Proof Testing, to test device in situ (2140)



Rosemount 9930 MLI (Sight Glass replacement)

- Enhance Safety
- Increased Visibility
- Minimize maintenance



Drain Tank / Sump Tank Level Control and ESD

Application Criticality

Drainage systems serve the following purpose:

- **Safety** To protect personnel, plant and equipment through a) preventing spillage or gas release to the environment and b) accumulation of hazardous liquid hydrocarbons, which could result in a fire or explosion.
- **Environment** To minimize and/or to prevent direct discharge of environmentally hazardous streams to the environment by directing these streams to appropriate treatment units.

Process Characteristics

- Generally ambient pressure and temperature
- **Measurement Challenges: Mixture of water and various hydrocarbon . Sand and other suspended solids may be present.**

Best Practice & advantage

- Non Contact Radar or Single rod probe best suited
- **NCR / GWR advance diagnostic can provide predictive maintenance and process alert incase of coating on antenna or probe.**
- **Accurately measures gross level even when non homogenous mix of fluid is present**

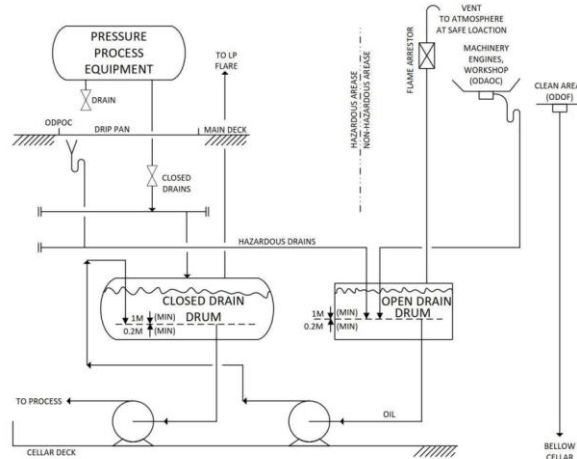
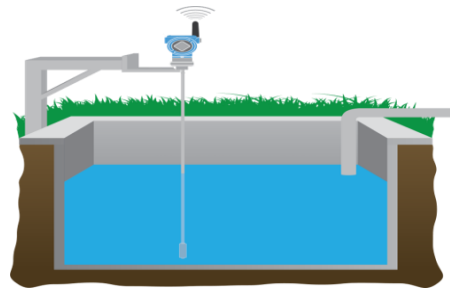
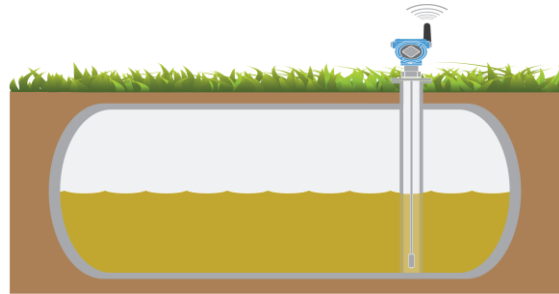

Rosemount 5408/3408 NCR (Control and ESD)

- Continuous monitoring and predictive maintenance alert incase of coating / condensation on antenna .

Rosemount 5300 GWR (Control and ESD)

- Continuous monitoring and predictive alert incase of coating on probe



Rosemount 2100

- High/Low Level detection (model 2120/2130)
- Remote Proof Testing, to test device in situ (2140)



Rosemount 9930 MLI

- Enhance Safety
- Increased Visibility
- Minimize maintenance

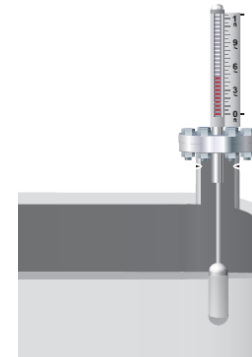

Level Measurement Control & ESD Upgrade Replacing Displacer with Guided Wave Radar

Why replace Displacer

- Reduce Maintenance
- Improved Diagnostics
- Multivariable measurement
- No mechanical modification
- Safety Certified

Best Practice

- Single probe or large coax probe best suited
- Large Coax probe , zero dead band , overflow safe
- Use existing Displacer Chamber or Rosemount 9935 Chamber

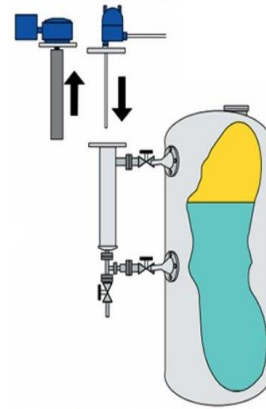

With GWR

- No moving parts , no wear and tear , no calibration
- Continues detection of coating , electronic and probe failure alerts
- Level & Interface from same device
- Easy Upgrade : No Mechanical onsite modification is required
- GWR available to ANSI/DIN/JIS and proprietary

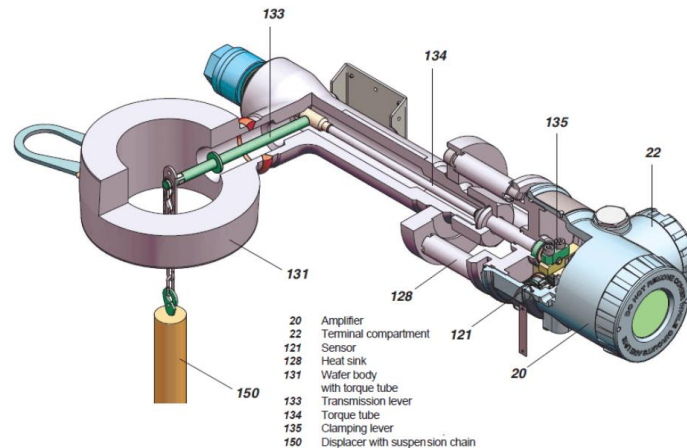

Level – Top 5 Applications



Primary Crusher Automation Level Application

- Primary crushers in mining reduce the size of raw feed from about 36"+ down to 6"-
- Haul trucks or other heavy mobile equipment dump blasted ore from the pit/underground into the primary crusher
- Crusher operators typically sound a horn and turn on a green signal light, directing the truck operator to dump ore

Challenges

- The amount of time crusher operators make some trucks wait before dumping ore is inconsistent
- In some cases, some crusher operators can be distracted by other tasks
- Primary crushers such as gyratory crushers operate optimally when they are choke fed with a constant load

Level solutions

- Non-contacting radar mounted on bracket above the crusher can help automate the dumping process
- The crusher operator's time can be re-purposed to do other more valuable tasks
- 5408 can accurately measure levels in fast-moving crushing applications to optimize crusher maintenance and operations
- 5408/2555 will help monitor fast moving level

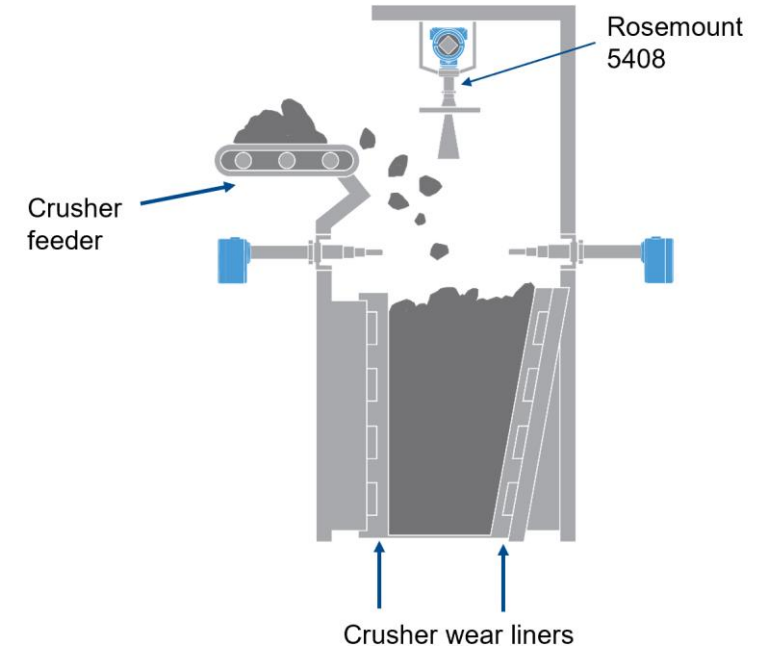

Featured Products:

- Rosemount 5408
- Rosemount 2555

Blocked Chute Detection Level Application

- Conveyor belts transfer bulk ore solids from one process to another
- Typical examples are, from primary crushing to secondary, secondary crushing to milling, etc
- Conveyor belt sections can only be so long, depending on the motor power ratings of drive systems
- One conveyor belt section dumps material on another, through transfer chutes

Challenges

- At the transfer chute, upstream conveyance can get damaged if downstream conveyance gets plugged
- Sometimes, ore gets cohesive and starts plugging the discharge of the transfer chute
- Other times, foreign debris such as metal pieces or wood can somehow find its way into crushed ore and get wedged on the discharge of the transfer chute.

Level solutions

- Non-contacting radar with parabolic antenna mounted on bracket above the transfer chute/hopper focuses on area of interest
- Overall range of measurement is up to 90 ft (30 m)
- 5408/3408 radar can help minimize downtime by continuously monitoring critical components and providing safe and cost-effective data collection for continued conveyor operation

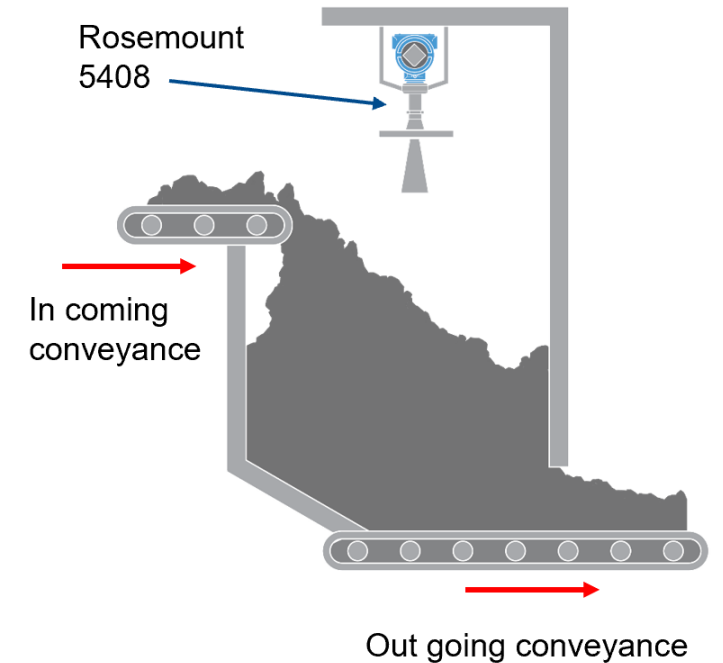

Featured Products:

- [Rosemount 5408](#)
- [Rosemount 3408](#)

Stockpiles and Silos Level Application

- Materials may include:
 - Copper concentrate powder
 - Alumina
 - Silica granules
 - Dry cement
 - Fly Ash
 - Lime
- Measurement needs:
 - Monitor overall level for drivers refilling silos
 - Reduced maintenance

Challenges

- Critical to know production supply is available
- Critical to know inventory for automatic re-ordering
- Dusty, uneven surfaces
- Filling and emptying can result in fast moving level changes

Level solutions

- The Rosemount 2500 Series Solid switches to optimize maintenance, timely cleaning and avoid shutdown.
- The Rosemount 5408/1208 Non-contacting Radar can accurately measure levels of media in storage silos to ensure continuous production despite dusty conditions
- Responsive to fast level changes – The 5408/1208 radars can measure the height of the pile
- Maintenance-free
- Accurate and trusted measurements allow automatic delivery scheduling

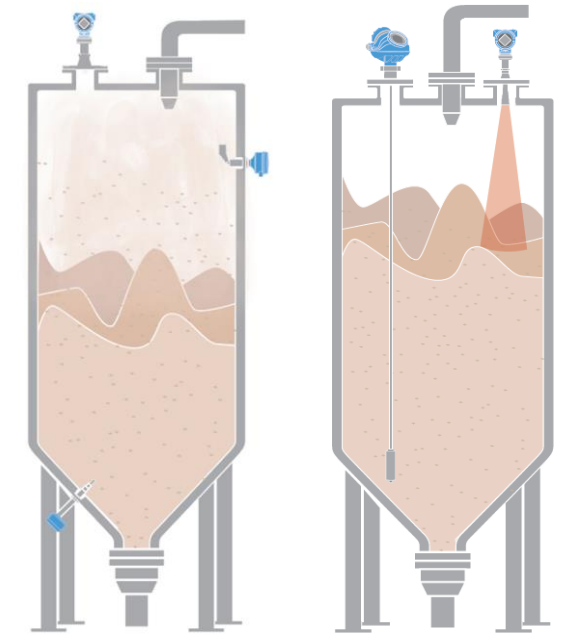

Featured Products:

- [Rosemount 2500](#)
- [Rosemount 5300](#)
- [Rosemount 5408](#)
- [Rosemount 1208](#)

Primary Crusher / Grinding Mill Lubrication Level Application

- Primary crushers and mills require lube oil to operate optimally and prevent unplanned downtime
- Lube oil prevents metal to metal contact of crusher and mill critical parts
- Lube oil also cools down critical parts of large crushers and mills

Challenges

- Primary crusher lube oil must always be maintained in good quantity at mine sites
- Mine sites receive lubricants in batches only so many times per week or per month
- Most mine sites are in remote locations, so last minute purchase of lubricants can be challenging

Level solutions

- Rosemount 5302 Guided Wave Radar - Thin Interface to detect water in oil
- Rosemount 2120 Vibrating Fork Switch - Overfill protection / Low level
- Rosemount 3308 Wireless Guided Wave Radar
- Rosemount 2160 Wireless Vibrating Fork Switch - True wireless for overfill protection / Low level control
- Rosemount 3051 Differential Pressure

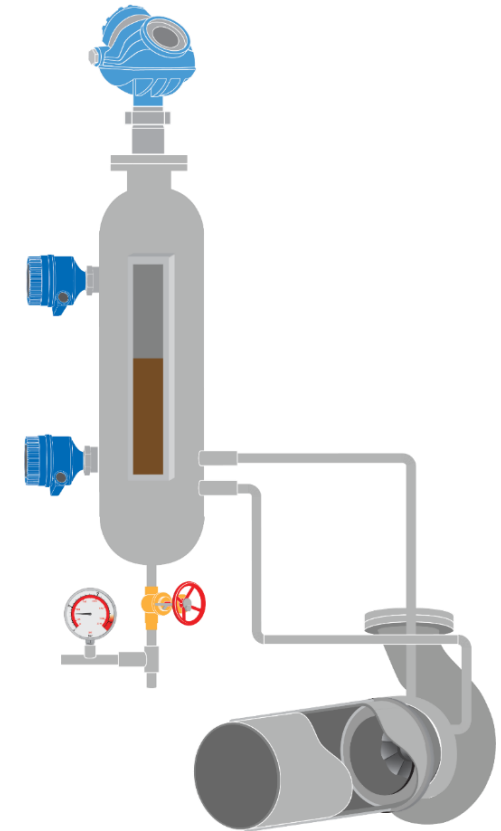

Featured Products:

- [Rosemount 5302](#)
- [Rosemount 2120](#)

Tailings Dam Water Level Application

- Monitoring the level of water at the tailing's dam/pond is critical to the safety of mine operations and surrounding communities.
- Also, making sure tailings and mine water are contained within the boundary of mining operations is critical to maintain environmental compliance of mine sites
- Safety and Sustainability are two most critical deliverables of mining operations
- Tailing Dams Monitoring Is Key For A Safe Operation

Challenges

- When the water level at the tailings pond gets higher than the dam, it has potential to overflow above the dam, and breach the foundation
- The above, if not mitigated, can cause potentially fatal flooding and environmental damage.
- When tailings water ponds get too high, the concentrator must be shut down, until the tailings water level is controlled
- Saturation build up can cause high pressure within the dam: Dam stability and collapse risk, environmental and safety risk & financial losses

Level solutions

- The Rosemount 1208 Non-contacting Radar can be deployed to perform the level measurements, regardless of challenging surface and weather conditions.
- 1208 Radar can be paired with the Rosemount 3490 Controller, to enhance operational safety, reduce the risk of dam failure, reduce operational cost/disruption, prevent downstream loss of life & ecological disaster as well as increase productivity.

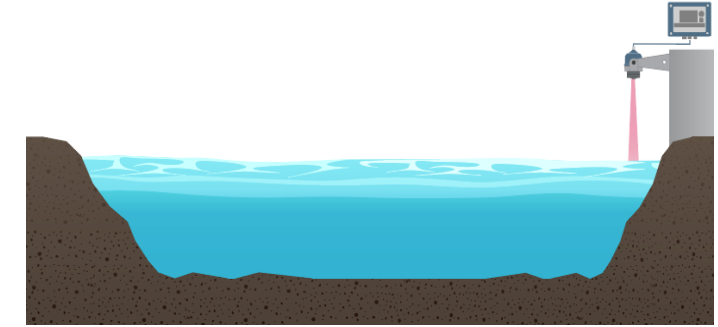

[Link to PAP >](#)

Featured Products:

- [Rosemount 1208](#)
- [Rosemount 3490](#)

Slurry Pump Protection Level Application

- Slurry pumps in mining applications are designed to operate optimally when they are pumping liquids
- The typical set up of these slurry pumps is downstream of a tank, sump or some form of reservoir
- These sumps or tanks act as slurry buffers between the slurry pump and the other process upstream
- These buffers provide the slurry pump with material to pump for a few minutes, if the process upstream shuts down, inadvertently

Challenges

- Slurry pumps get damaged (Cavitation) when they pump air
- When the process providing slurry from upstream shuts down, the slurry pump needs to be shut down immediately
- When the level of a sump gets low, the slurry pump gets shut down, before it pumps air
- Slurry pump damage can cost tens of thousands of dollars in equipment, and hundreds of thousands in lost production

Level solutions

- The Rosemount 1208 no-contacting radar can help to monitor accurately the inside of these vessels to avoid overfills and ensure efficient processes. The Rosemount 1208 Transmitter is reliable, easy to use and remains unaffected by process conditions (such as turbulence generated by agitators).
- The Rosemount 1208 can be paired to the Rosemount 3490 Controller, which enables mining to comply with regulation by having a continuous access to detailed data to share with authorities.

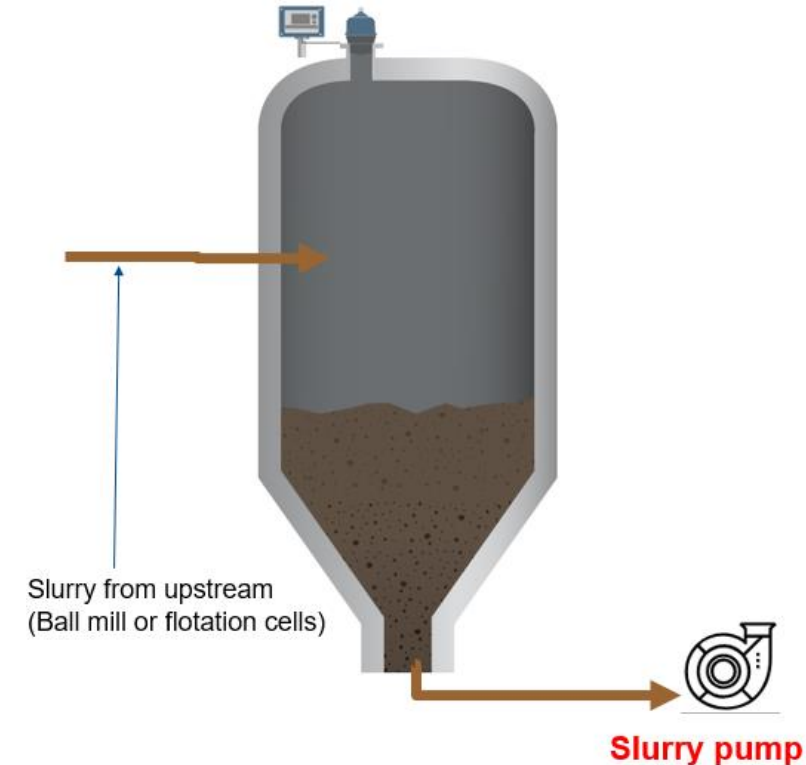

Featured Products:

- [Rosemount 1208](#)
- [Rosemount 3490](#)