

# Rosemount™ 3144P Temperature Transmitter

with Rosemount X-well™ Technology



With the Rosemount 3144P Temperature Transmitter, you gain greater visibility into your temperature processes so you can:

- Improve safety
- Comply with regulations
- Make the most of your limited resources
- Reach your production and quality targets

By leveraging Rosemount X-well Technology, advanced diagnostic capabilities, and the unparalleled reliability and accuracy of the transmitter, you can:

- Minimize off-spec product
- Reduce maintenance and downtime
- Improve the usage of your limited resources
- Meet regulatory demands

## Features and benefits

### Complete Point Solution™ for accurately measuring process temperature in monitoring applications without the requirement of a thermowell or process penetration



- Simplify temperature measurement point specification, installation, and maintenance and eliminate possible leak points.
- Calculate a repeatable and accurate process temperature measurement with an in-transmitter thermal conductivity algorithm.
- Measure pipe surface and ambient temperature and use the thermal conductivity properties of the installation and process piping in order to provide an accurate process measurement.

### Access information when you need it with asset tags

Newly shipped devices include a unique QR code asset tag, which enables you to access serialized information directly from the device. With this capability, you can:

- Access device drawings, diagrams, technical documentation, and troubleshooting information in your MyEmerson account.
- Improve mean time to repair and maintenance efficiency.
- Ensure confidence that you have located the correct device.
- Eliminate the time-consuming process of locating and transcribing nameplates to view asset information.

---

### Contents

Features and benefits.....	2
Ordering information.....	5
How to order Rosemount X-well Technology.....	12
Specifications.....	13
Product certifications.....	25
Dimensional drawings.....	26

## Deliver unmatched field reliability and innovative process measurement solutions

- Superior accuracy and stability
- Dual and single sensor capability with universal sensor inputs (RTD, thermocouple, mV, ohms)
- Comprehensive sensor and process diagnostics offering
- SIL3 capable: IEC 61508 certified by an accredited third party agency for use in safety instrumented systems up to SIL 3 (minimum requirement of single use [1oo1] for SIL 2 and redundant use [1oo2] for SIL 3)
- Dual-compartment housing
- Large LCD display
- 4–20 mA HART® with selectable revisions (5 and 7)
- FOUNDATION™ Fieldbus, compliant to ITK 6.0 and NE107 standards



## Improve efficiency with best-in-class product specifications and capabilities

- Reduce maintenance and improve performance with industry leading accuracy and stability.
- Improve measurement accuracy by 75 percent with transmitter-sensor matching.
- Ensure process health with system alerts and user-friendly device dashboards.
- Easily check device status and values on local LCD display with large percent range graph.
- Achieve high reliability and installation ease with the industry's most rugged dual compartment design.

## Optimize measurement reliability with diagnostics designed for any protocol on any host system

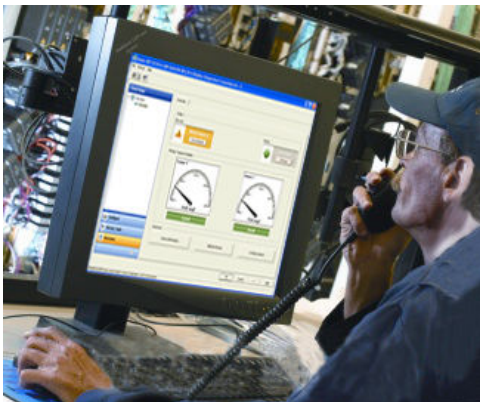

- Thermocouple degradation diagnostic monitors the health of a thermocouple loop, enabling preventative maintenance.
- Minimum and maximum temperature tracking tracks and records temperature extremes of the process sensors and the ambient environment.
- Sensor drift alert detects sensor drift and alerts the user.
- The Hot Backup™ feature provides temperature measurement redundancy.

## Explore the benefits of a Complete Point Solution from Emerson

- An “Assemble To Sensor” option enables Emerson to provide a complete point temperature solution, delivering an installation-ready transmitter and sensor assembly.
- Emerson offers a selection of RTDs, thermocouples, and thermowells that bring superior durability and Rosemount reliability to temperature sensing, complementing the Rosemount Transmitter portfolio.

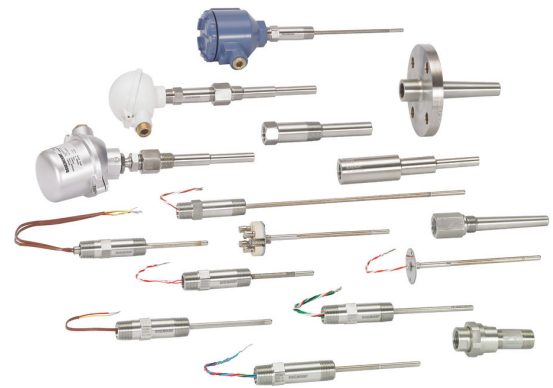

## Experience global consistency and local support from numerous worldwide Emerson manufacturing sites

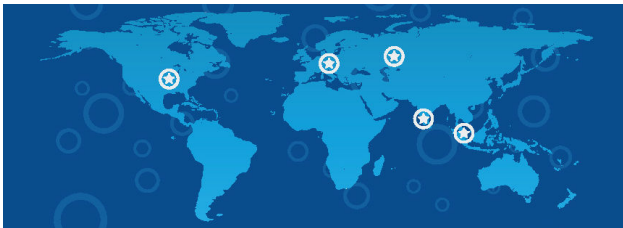

- World-class manufacturing provides globally consistent products from every factory and the capacity to fulfill the needs of any project, large or small.
- Experienced instrumentation consultants help select the right product for any temperature application and advise on best installation practices.
- An extensive global network of Emerson service and support personnel can be on-site when and where they are needed.
- Make wireless installation and configuration easy with the Emerson Wireless Gateway.

Looking for a wireless temperature solution? For wireless applications that require superior performance and unmatched reliability, consider the [Rosemount 648 Wireless Temperature Transmitter](#).

# Ordering information



The industry-leading Rosemount 3144P Temperature Transmitter delivers unmatched field reliability and innovative process measurement solutions and diagnostics.

Transmitter features include:

- Temperature measurement assembly with Rosemount X-well Technology (option code PT)
- Dual and single sensor input capabilities
- Transmitter-sensor matching (option code C2)
- Integral transient protector (option code T1)
- IEC 61508 Safety Certificate of Compliance (option code QT)
- Advanced sensor and process diagnostics (option codes D01 and DA1)
- Large, easy to read LCD display (option code M5)
- "Assemble to Sensor" option (option code XA)

CONFIGURE >	VIEW PRODUCT >
-------------	----------------

## Online product configurator

Many products are configurable online using our Product Configurator. Select the **Configure** button or visit [Emerson.com](https://emerson.com) to start. With this tool's built-in logic and continuous validation, you can configure your products more quickly and accurately.

## Model codes

Model codes contain the details related to each product. Exact model codes will vary. An example of a typical model code is shown in [Figure 1](#).

Figure 1: Model code example

<b>3144P D1 A 1 NA</b>	<b>M5 DA1 Q4</b>
<b>1</b>	<b>2</b>

1. Required model components (choices available on most)
2. Additional options (variety of features and functions that may be added to products)

## Specifications and options

The purchaser of the equipment must specify and select the product materials, options, or components.

## Optimizing lead time

The starred offerings (★) represent the most common options and should be selected for the fastest delivery times. The non-starred offerings are subject to additional delivery lead time.

## Required model components

### Model

Code	Description	
3144P	Temperature transmitter	★

### Housing style

Code	Description	Material	Conduit entry size	
D1	Field mount housing, dual-compartment housing	Aluminum	½–14-in. NPT	★
D2	Field mount housing, dual-compartment housing	Aluminum	M20 x 1.5 (CM20)	★
D3	Field mount housing, dual-compartment housing	Aluminum	PG 13.5 (PG11)	★
D4	Field mount housing, dual-compartment housing	Aluminum	JIS G ½	★
D5	Field mount housing, dual-compartment housing	Stainless steel	½–14-in. NPT	★
D6	Field mount housing, dual-compartment housing	Stainless steel	M20 x 1.5 (CM20)	★
D7	Field mount housing, dual-compartment housing	Stainless steel	PG 13.5 (PG11)	★
D8	Field mount housing, dual-compartment housing	Stainless steel	JIS G ½	★
D9	Field mount housing, dual-compartment housing	Aluminum, ultra low copper	½–14-in. NPT	
D0	Field mount housing, dual-compartment housing	Aluminum, ultra low copper	M20 x 1.5 (CM20)	

### Transmitter output

Code	Description	
A	4–20 mA with digital signal based on HART Protocol	★
F	FOUNDATION Fieldbus digital signal (includes three analog input function block and backup link active scheduler)	★

## Measurement configuration

Code	Description	
1	Single-sensor input	★
2	Dual-sensor input	★

## Product certification

Code	Description	
NA	No approval	★
E5	USA explosion-proof, dust ignition-proof, and non-incendive	★
I5 <sup>(1)</sup>	USA Intrinsically Safe (IS) and non-incendive (includes standard IS and FISCO for Fieldbus units)	★
K5 <sup>(1)</sup>	USA IS, non-incendive, and explosion-proof combination (includes standard IS and FISCO for Fieldbus units)	★
KB <sup>(1)</sup>	USA and Canada IS, explosion-proof, and non-incendive combination (includes standard IS and FISCO for Fieldbus units)	★
I6 <sup>(1)</sup>	Canada IS/FISCO, and Division 2 (includes standard IS and FISCO for Fieldbus units)	★
K6 <sup>(1)</sup>	Canada IS, FISCO Division 2, and explosion-proof combination (includes standard IS, FISCO for Fieldbus units)	★
E1	ATEX flameproof approval	★
N1	ATEX type n approval	★
I1 <sup>(1)</sup>	ATEX intrinsic safety approval (includes standard IS and FISCO for Fieldbus units)	★
K1 <sup>(1)</sup>	ATEX IS, flameproof, dust ignition-proof and type n combination (includes standard IS and FISCO for Fieldbus units)	★
ND	ATEX dust ignition-proof approval	★
KA <sup>(1)</sup>	ATEX/Canada intrinsic safety, explosion-proof combination (includes standard IS and FISCO for Fieldbus units)	★
E7	IECEX flameproof approval	★
N7	IECEX Type 'n' approval	★
I7 <sup>(1)(2)</sup>	IECEX intrinsic safety	★
K7 <sup>(1)(2)</sup>	IECEX intrinsic safety, flameproof, dust ignition-proof and type n combination	★
E2 <sup>(2)</sup>	Brazil flameproof	★
I2 <sup>(2)</sup>	Brazil intrinsic safety	★
E4 <sup>(2)</sup>	Japan flameproof approval	★
E3 <sup>(2)</sup>	China flameproof approval	★
I3 <sup>(1)(2)</sup>	China intrinsic safety	★
N3	China type n	★
KM	Technical Regulations Customs Union (EAC) flameproof, intrinsic safety	★
IM	Technical Regulations Customs Union (EAC) intrinsic safety	★
EM	Technical Regulations Customs Union (EAC) flameproof	★

(1) When IS approval is ordered on a FOUNDATION™ Fieldbus, both standard IS and FISCO IS approvals apply. The device label is marked appropriately.

(2) Consult factory for availability when ordering with HART or FOUNDATION Fieldbus models.

## Additional options

### Plantweb™ control functionality

Code	Description	
A01	FOUNDATION™ Fieldbus advanced control function block suite	★

### Plantweb advanced diagnostic functionality

Code	Description	
D01	FOUNDATION Fieldbus sensor and process diagnostic suite: thermocouple diagnostic, minimum/maximum tracking	★
DA1	sensor and process diagnostic suite: thermocouple diagnostic, minimum/maximum tracking	★

### Enhanced performance

Code	Description	
PT <sup>(1)</sup>	Temperature measurement assembly with Rosemount X-well Technology	★
P8 <sup>(2)</sup>	Enhanced transmitter accuracy	★

(1) Not available with FOUNDATION Fieldbus models.

(2) Enhanced accuracy only applies to RTDs; however the option can be ordered with any sensor type.

### Mounting bracket

Code	Description	
B4	"U" mounting bracket for 2-in. pipe mounting - all SST	★
B5	"L" mounting bracket for 2-in. pipe or panel mounting - all SST	★
BH	"L" mounting bracket for 2-in. pipe or panel mounting - 316 SST	★

### Display

Code	Description	
M5	LCD display	★

### External ground

Code	Description	
G1	External ground lug assembly	★

### Transient protector

Code	Description	
T1	Integral transient protector	★

## Software configuration

Not available with FOUNDATION™ Fieldbus models.

Code	Description	
C1	Custom configuration of date, descriptor, and message (requires <a href="#">Configuration Data Sheet</a> with order)	★

## Line filter

Code	Description	
F5	50 Hz line voltage filter	★

## Alarm level configuration

Not available with FOUNDATION™ Fieldbus models.

Code	Description	
A1	NAMUR alarm and saturation levels, high alarm	★
CN	NAMUR alarm and saturation levels, low alarm	★

## Low alarm

Code	Description	
C8	Low alarm (standard Rosemount alarm and saturation values)	★

## Sensor trim

Code	Description	
C2	Transmitter-sensor matching - trim to PT100 RTD calibration schedule (Callendar-Van Dusen constants)	★
C7	Trim to non-standard sensor (special sensor-customer must provide sensor information)	

## Five-point calibration

Code	Description	
C4	5-point calibration (requires the Q4 option code to generate a calibration certificate)	★

## Calibration certification

Code	Description	
Q4	Calibration certificate (3-point calibration)	★
QG	Calibration certificate and GOST verification certificate	★
QP	Calibration certificate and tamper evident seal	★

## Dual-input custom configuration (only with measurement type option code 2)

Code	Description	
U1	Hot Backup™	★
U2 <sup>(1)</sup>	Average temperature with Hot Backup and sensor drift alert – warning mode	★
U3 <sup>(1)</sup>	Average temperature with Hot Backup and sensor drift alert – alarm mode	★
U5	Differential temperature	★
U6	Average temperature	★
U7	First good temperature	★
U4	Two independent sensors	

(1) Not available with FOUNDATION™ Fieldbus models.

## Custody transfer

Not available with FOUNDATION Fieldbus models.

Code	Description	
D3	Custody transfer approval (Canada)	
D4	MID custody transfer (Europe)	

## Quality certification for safety

Code	Description	
QS	Prior-use certificate of FMEDA data ( only)	★
QT	Safety-certified to IEC 61508 with certificate of FMEDA data (HART only)	★

## Shipboard Certification

Code	Description	
SBS	American Bureau of Shipping (ABS) Type Approval	★
SBV	Bureau Veritas (BV) Type Approval	★
SDN	Det Norske Veritas (DNV) Type Approval	★
SLL	Lloyd's Register (LR) Type Approval	★

## Cold temperature

Code	Description	
BR6	-76 °F (-60 °C) cold temperature operation	★

## Conduit electrical connector

Available with intrinsically safe approvals only. For FM Intrinsically Safe or non-incendive approval (option code I5), install in accordance with Rosemount drawing 03151-1009 to maintain 4X rating.

Code	Description	
GE	M12, 4-pin, male connector (eurofast®)	★

Code	Description	
GM	A size mini, 4-pin, male connector (minifast®)	★

### HART revision configuration

Code	Description	
HR7	Configured for HART Revision 7	★

### Assemble to option

Code	Description	
XA	Sensor specified separately and assembled to transmitter	★

### Extended product warranty

Code	Description	
WR3	Three-year limited warranty	★
WR5	Five-year limited warranty	★

## How to order Rosemount X-well Technology

Rosemount X-well™ Technology is for temperature monitoring applications and is not intended for control or safety applications. It is available in the Rosemount 3144P Temperature Transmitter in a factory assembled direct mount configuration with a Rosemount 0085 Pipe Clamp Sensor. It cannot be used in a remote mount configuration. Rosemount X-well Technology will only work as specified with factory supplied and assembled Rosemount 0085 Sensor silver tipped single element sensor with an 3.15-in. (80 mm) extension length. It will not work as specified if used with other sensors.

**Table 1: Rosemount 3144P Temperature Transmitter X-well Technology option code requirements**

Code	Description
D1-D4	Aluminum field mount housing
PT	Temperature measurement assembled with Rosemount X-well Technology
A	4–20 mA with digital signal based on HART Protocol
XA	Sensor specified separately and assembled to transmitter
C1	Custom configuration of date, descriptor, message, and wireless parameters (requires <a href="#">Configuration Data Sheet</a> with order)
HR7	Configured for HART Revision 7

**Table 2: Rosemount 0085 Pipe Clamp Sensor option code requirements for use with X-well Technology**

Code	Description
N	No connection head
3	Sensor connection
P1	Sensor type
J	Extension type
0080	Extension length
XA	Assemble sensor to specific temperature transmitter

Rosemount X-well assemblies are available in most Rosemount 0085 Pipe Clamp Sensor diameter sizes.

<p><b>Typical model numbers of the assembly:</b>  <b>3144P D 1A 1 NA M5 PT C1 HR7 XA</b>  <b>0085 N 3 P1 J 0080 U 0169 N XA</b></p>
---

# Specifications

## HART® and FOUNDATION™ Fieldbus

### Functional specifications

#### Inputs

User-selectable. See [Table 3](#) for sensor options.

#### Output

Two-wire device with either 4–20 mA/HART, linear with temperature or input, or completely digital output with FOUNDATION™ Fieldbus Communication (ITK 6.0.1 compliant).

#### Isolation

Input/output isolation specified to 500 Vdc (500 Vrms 707 V peak) at 50/60 Hz.

#### Humidity limits

0–99 percent relative humidity, non-condensing

#### Update time

Approximately 0.5 seconds for a single sensor (one second for dual sensors).

### Physical specifications

#### Material selection

Emerson provides a variety of Rosemount products with various product options and configurations, including materials of construction that can be expected to perform well in a wide range of applications. The Rosemount product information presented is intended as a guide for the purchaser to make an appropriate selection for the application. It is the purchaser's sole responsibility to make a careful analysis of all process parameters (such as all chemical components, temperature, pressure, flow rate, abrasives, contaminants, etc.), when specifying product, materials, options, and components for the particular application. Emerson is not in a position to evaluate or guarantee the compatibility of the process fluid or other process parameters with the product, options, configuration, or materials of construction selected.

#### Conformance to specification ( $\pm 3\sigma$ [Sigma])

Technology leadership, advanced manufacturing techniques, and statistical process control ensure specification conformance to at least  $\pm 3\sigma$ .

#### Conduit connections

The standard field mount housing has ½–1¼-in. NPT conduit entries. Additional conduit entry types are available, including PG13.5 (PG11), M20 3 1.5 (CM20), or JIS G ½. When any of these additional entry types are ordered, adapters are placed in the standard field housing so these alternative conduit types fit correctly.

#### Materials of construction

<b>Enclosure</b>	Low-copper aluminum or CF-8M (cast version of 316 stainless steel)
<b>Paint</b>	Polyurethane
<b>O-rings</b>	Buna N

#### Mounting specification

Transmitters may be attached directly to the sensor. Optional mounting brackets (codes B4 and B5) allow for remote mounting. See [Figure 6](#).

**Transmitter weight****Aluminum** 3.1 lb. (1.4 kg)**Stainless steel** 7.8 lb. (3.5 kg)**Enclosure ratings**

Type 4X

IP66 and IP68

**Stability****RTDs:**  $\pm 0.1$  percent of reading or 0.1 °C (0.18 °F), whichever is greater, for two years for RTDs.**Thermocouples:**  $\pm 0.1$  percent of reading or 0.1 °C (0.18 °F), whichever is greater, for one year for thermocouples.**Five-year stability****RTDs:**  $\pm 0.25$  percent of reading or 0.25 °C, whichever is greater, for five years.**Thermocouples:**  $\pm 0.5$  percent of reading or 0.5 °C, whichever is greater, for five years.**Vibration effect**

Tested to the following with no effect on performance per IEC 60770-1, 1999:

Frequency	Vibration
10 to 60 Hz	0.21 mm displacement
60 to 2000 Hz	3 g peak acceleration

**Self calibration**

The analog-to-digital measurement circuitry automatically self-calibrates for each temperature update by comparing the dynamic measurement to extremely stable and accurate internal reference elements.

**Radio frequency interference (RFI) effect**

Worst case RFI effect is equivalent to the transmitter's nominal accuracy specification, when tested in accordance with IEC 61000-4-3, 30 V/m (HART®)/20 V/m (HART thermocouple (T/C)) /10 V/m (FOUNDATION Fieldbus), 80 to 1000 MHz, with unshielded cable.

**Electromagnetic compatibility (EMC)**

Meets all industrial environment requirements of EN61326 and NAMUR NE-21. Maximum deviation <1 percent span during EMC disturbance.

**Note**

During surge event, device may exceed maximum EMC deviation limit; however, device will self-recover and return to normal operation within specified start-up time.

### External ground screw assembly

The external ground screw assembly can be ordered by specifying [code G1](#). However, some approvals include the ground screw assembly in the transmitter shipment; hence it is not necessary to order code G1. The following table identifies which approval options include the external ground screw assembly.

Approval type	External ground screw assembly included? <sup>(1)</sup>
E5, I1, I2, I5, I6, I7, K5, K6, KB, NA	No-order option code G1
E1, E2, E3, E4, E7, K1, K7, KA, N1, N7, ND, NF	Yes

(1) *The parts contained with the G1 option are included with the Integral Protector option code T1. When ordering T1, the G1 option code does not need to be ordered separately.*

### Hardware tag

- No charge
- Two lines of 28 characters (56 characters total)
- Tags are stainless steel
- Permanently attached to transmitter
- Character height is 1/16-in. (1.6 mm)
- A wire-on tag is available upon request. Five lines of 12 characters (60 characters total)

### Software tag

- HART<sup>®</sup> transmitter can store up to eight characters in HART 5 mode and 32 characters in HART 7 mode. FOUNDATION Fieldbus transmitters can store up to 32 characters.
- Can be ordered with different software and hardware tags.
- If no software tag characters are specified, the first eight characters of the hardware tag are the default.

### Transmitter accuracy

**Table 3: Transmitter accuracy**

Sensor options	Sensor reference	Input ranges		Minimum span <sup>(1)</sup>		Digital accuracy <sup>(2)</sup>		Enhanced accuracy <sup>(3)</sup>	D/A accuracy <sup>(4)(5)</sup>
		°C	°F	°C	°F	°C	°F	°C	
<b>2-, 3-, 4-wire RTDs</b>									
Pt 100 ( $\alpha = 0.00385$ )	IEC 751	-200 to 850	-328 to 1562	10	18	$\pm 0.10$	$\pm 0.18$	$\pm 0.08$	$\pm 0.02\%$ of span
Rosemount X-well Pt 100	( $\alpha = 0.00385$ )	IEC 751	-58 to 572	10	18	$\pm 0.29$	$\pm 0.52$	N/A	$\pm 0.02\%$ of span
Pt 200 ( $\alpha = 0.00385$ )	IEC 751	-200 to 850	-328 to 1562	10	18	$\pm 0.22$	$\pm 0.40$	$\pm 0.176$	$\pm 0.02\%$ of span
Pt 500 ( $\alpha = 0.00385$ )	IEC 751	-200 to 850	-328 to 1562	10	18	$\pm 0.14$	$\pm 0.25$	$\pm 0.112$	$\pm 0.02\%$ of span
Pt 1000 ( $\alpha = 0.00385$ )	IEC 751	-200 to 300	-328 to 1193	10	18	$\pm 0.10$	$\pm 0.18$	$\pm 0.08$	$\pm 0.02\%$ of span
Pt 100 ( $\alpha = 0.003916$ )	JIS 1604	-200 to 645	-328 to 1193	10	18	$\pm 0.10$	$\pm 0.18$	$\pm 0.08$	$\pm 0.02\%$ of span
Pt 200 ( $\alpha = 0.003916$ )	JIS 1604	-200 to 645	-94 to 572	10	$\pm 0.22$	$\pm 0.40$	$\pm 0.40$	$\pm 0.176$	$\pm 0.02\%$ of span
Ni 120	Edison curve no. 7	-70 to 300	-58 to 482	10	18	$\pm 0.08$	$\pm 0.14$	$\pm 0.064$	$\pm 0.02\%$ of span

Table 3: Transmitter accuracy (continued)

Sensor options	Sensor reference	Input ranges		Minimum span <sup>(1)</sup>		Digital accuracy <sup>(2)</sup>		Enhanced accuracy <sup>(3)</sup>	D/A accuracy <sup>(4)(5)</sup>
Cu 10	Edison copper winding no. 15	-50 to 250	-328 to 1022	10	18	± 1.00	± 1.80	± 0.8	± 0.02% of span
Pt 50 (α=0.00391)	GOST 6651-94	-200 to 550	-328 to 1022	10	18	± 0.20	± 0.36	± 0.16	± 0.02% of span
Pt 100 (α=0.00391)	GOST 6651-94	-200 to 550	-328 to 1022	10	18	± 0.10	± 0.18	± 0.08	± 0.02% of span
Cu 50 (α=0.00426)	GOST 6651-94	-50 to 200	-58 to 392	10	18	± 0.34	± 0.61	± 0.272	± 0.02% of span
Cu 50 (α=0.00428)	GOST 6651-94	-185 to 200	-301 to 392	10	18	± 0.34	± 0.61	± 0.272	± 0.02% of span
Cu 100 (α=0.00426)	GOST 6651-94	-50 to 200	-58 to 392	10	18	± 0.17	± 0.31	± 0.136	± 0.02% of span
Cu 100 (α=0.00428)	GOST 6651-94	-185 to 200	-301 to 392	10	18	± 0.17	± 0.31	± 0.136	± 0.02% of span
<b>Thermocouples<sup>(6)</sup></b>									
Type B <sup>(7)</sup>	NIST monograph 175, IEC 584	100 to 1820	212 to 3308	25	45	± 0.75	± 1.35	N/A	± 0.02% of span
Type E	NIST monograph 175, IEC 584	-200 to 1000	-328 to 1832	25	45	± 0.20	± 0.36	N/A	± 0.02% of span
Type J	NIST monograph 175, IEC 584	-180 to 760	-292 to 1400	25	45	± 0.25	± 0.45	N/A	± 0.02% of span
Type K <sup>(8)</sup>	NIST monograph 175, IEC 584	-180 to 1372	-292 to 2501	25	45	± 0.25	± 0.45	N/A	± 0.02% of span
Type N	NIST monograph 175, IEC 584	-200 to 1300	-328 to 2372	25	45	± 0.40	± 0.72	N/A	± 0.02% of span
Type R	NIST monograph 175, IEC 584	0 to 1768	32 to 3214	25	45	± 0.60	± 1.08	N/A	± 0.02% of span
Type S	NIST monograph 175, IEC 584	0 to 1768	32 to 3214	25	45	± 0.50	± 0.90	N/A	± 0.02% of span
Type T	NIST monograph 175, IEC 584	-200 to 400	-328 to 752	25	45	± 0.25	± 0.45	N/A	± 0.02% of span
DIN Type L	DIN 43710	-200 to 900	-328 to 1652	25	45	± 0.35	± 0.63	N/A	± 0.02% of span
DIN Type U	DIN 43710	-200 to 600	-328 to 1112	25	45	± 0.35	± 0.63	N/A	± 0.02% of span
Type W5Re/W26Re	ASTM E 988-96	0 to 2000	32 to 3632	25	45	± 0.70	± 1.26	N/A	± 0.02% of span
GOST Type L	GOST R 8.585-2001	-200 to 800	-392 to 1472	25	45	± 0.25	± 0.45	N/A	± 0.02% of span

**Table 3: Transmitter accuracy (continued)**

Sensor options	Sensor reference	Input ranges	Minimum span <sup>(1)</sup>	Digital accuracy <sup>(2)</sup>	Enhanced accuracy <sup>(3)</sup>	D/A accuracy <sup>(4)(5)</sup>
<b>Other input types</b>						
Millivolt input		-10 to 100 mV	3 mV	± 0.015 mV	N/A	± 0.02% of span
2-, 3-, 4-wire Ohm Input		0 to 2000 ohms	20 ohm	± 0.35 ohm	N/A	± 0.02% of span

(1) No minimum or maximum span restrictions within the input ranges. Recommended minimum span will hold noise within accuracy specification with damping at zero seconds.

(2) Digital accuracy: digital output can be accessed by the Field Communicator.

(3) Enhanced accuracy can be ordered using the P8 model code.

(4) Total analog accuracy is the sum of digital and D/A accuracies.

(5) Applies to 4–20 mA devices.

(6) Total digital accuracy for thermocouple measurement: sum of digital accuracy +0.25 °C (0.45 °F) (cold junction accuracy)

(7) Digital accuracy for NIST Type B is ±3.0 °C (±5.4 °F) from 100 to 300 °C (212 to 572 °F).

(8) Digital accuracy for NIST Type K is ±0.50 °C (±0.9 °F) from -180 to -90 °C (-292 to -130 °F).

### Reference accuracy example (HART Protocol only)

When using a Pt 100 ( $\alpha = 0.00385$ ) sensor input with a 0 to 100 °C span: Digital accuracy would be ±0.10 °C, D/A accuracy would be ±0.02% of 100 °C or ±0.02 °C, Total = ±0.12 °C.

### Differential capability exists between any two sensor types (dual-sensor option)

For all differential configurations, the input range is X to Y where:

- X = Sensor 1 minimum – Sensor 2 maximum
- Y = Sensor 1 maximum – Sensor 2 minimum

### Digital accuracy for differential configurations (dual-sensor option, HART Protocol only)

- Sensor types are similar (e.g., both RTDs or both thermocouples (T/Cs)): Digital accuracy = 1.5 times worst case accuracy of either sensor type
- Sensor types are dissimilar (e.g., one RTD, one T/C): Digital accuracy = Sensor 1 accuracy + Sensor 2 accuracy

### Ambient temperature effect

Transmitters may be installed in locations where the ambient temperature is between -40 and 85 °C (-40 and 185 °F). To maintain excellent accuracy performance, each transmitter is individually characterized over this ambient temperature range at the factory.

**Table 4: Ambient temperature effect on digital accuracy**

Sensor options	Sensor reference	Effect per 1.0 °C (1.8 °F) change in ambient <sup>(1)(2)</sup>	Input temperature (T)	D/A effect <sup>(3)</sup>
<b>2-, 3-, or 4-wire RTDs</b>				
Pt 100 ( $\alpha = 0.00385$ )	IEC 751	0.0015 °C (0.0027 °F)	Entire sensor input range	0.001% of span
Rosemount X-well Pt 100 ( $\alpha = 0.00385$ )	IEC 751	0.0058 °C (0.0104 °F)	Entire sensor input range	0.001% of span
Pt 200 ( $\alpha = 0.00385$ )	IEC 751	0.0023 °C (0.00414 °F)	Entire sensor input range	0.001% of span
Pt 500 ( $\alpha = 0.00385$ )	IEC 751	0.0015 °C (0.0027 °F)	Entire sensor input range	0.001% of span
Pt 1000 ( $\alpha = 0.00385$ )	IEC 751	0.0015 °C (0.0027 °F)	Entire sensor input range	0.001% of span

**Table 4: Ambient temperature effect on digital accuracy (continued)**

Sensor options	Sensor reference	Effect per 1.0 °C (1.8 °F) change in ambient <sup>(1)(2)</sup>	Input temperature (T)	D/A effect <sup>(3)</sup>
Pt 100 (α = 0.003916)	JIS 1604	0.0015 °C (0.0027 °F)	Entire sensor input range	0.001% of span
Pt 200 (α = 0.003916)	JIS 1604	0.0023 °C (0.00414 °F)	Entire sensor input range	0.001% of span
Ni 120	Edison curve no. 7	0.0010 °C (0.0018 °F)	Entire sensor input range	0.001% of span
Cu 10	Edison copper winding no. 15	0.015 °C (0.0027 °F)	Entire sensor input range	0.001% of span
Pt 50 (α = 0.00391)	GOST 6651-94	0.003 °C (0.0054 °F)	Entire sensor input range	0.001% of span
Pt 100 (α = 0.00391)	GOST 6651-94	0.0015 °C (0.0027 °F)	Entire sensor input range	0.001% of span
Cu 50 (α = 0.00426)	GOST 6651-94	0.003 °C (0.0054 °F)	Entire sensor input range	0.001% of span
Cu 50 (α = 0.00428)	GOST 6651-94	0.003 °C (0.0054 °F)	Entire sensor input range	0.001% of span
Cu 100 (α = 0.00426)	GOST 6651-94	0.0015 °C (0.0027 °F)	Entire sensor input range	0.001% of span
Cu 100 (α = 0.00428)	GOST 6651-94	0.0015 °C (0.0027 °F)	Entire sensor input range	0.001% of span
<b>Thermocouples</b>				
Type B	NIST monograph 175, IEC 584	0.014 °C 0.029 °C – 0.0021% of (T – 300) 0.046 °C – 0.0086% of (T – 100)	T ≥ 1000 °C 300 °C ≤ T < 1000 °C 100 °C ≤ T < 300 °C	0.001% of span
Type E	NIST monograph 175, IEC 584	0.004 °C + 0.00043% of T	N/A	0.001% of span
Type J	NIST monograph 175, IEC 584	0.004 °C + 0.00029% of T 0.004 °C + 0.0020% of abs. val. T	T ≥ 0 °C T < 0 °C	0.001% of span
Type K	NIST monograph 175, IEC 584	0.005 °C + 0.00054% of T 0.005 °C + 0.0020% of abs. val. T	T ≥ 0 °C T < 0 °C	0.001% of span
Type N	NIST monograph 175, IEC 584	0.005 °C + 0.00036% of T	All	0.001% of span
Type R	NIST monograph 175, IEC 584	0.015 °C 0.021 °C – 0.0032% of T	T ≥ 200 °C T < 200 °C	0.001% of span
Type S	NIST monograph 175, IEC 584	0.015 °C 0.021 °C – 0.0032% of T	T ≥ 200 °C T < 200 °C	0.001% of span
Type T	NIST monograph 175, IEC 584	0.005 °C 0.005 °C + 0.0036% of abs. val. T	T ≥ 0 °C T < 0 °C	0.001% of span
DIN Type L	DIN 43710	0.0054 °C + 0.00029% of R 0.0054 °C + 0.0025% of abs. val. T	T ≥ 0 °C T < 0 °C	0.001% of span

**Table 4: Ambient temperature effect on digital accuracy (continued)**

Sensor options	Sensor reference	Effect per 1.0 °C (1.8 °F) change in ambient <sup>(1)(2)</sup>	Input temperature (T)	D/A effect <sup>(3)</sup>
DIN Type U	DIN 43710	0.0064 °C 0.0064 °C + 0.0043% of abs. val. T	T ≥ 0 °C T < 0 °C	0.001% of span
Type W5Re/W26Re	ASTM E 988-96	0.016 °C 0.023 °C + 0.0036% of T	T ≥ 200 °C T < 200 °C	0.001% of span
GOST Type L	GOST R 8.585–2001	0.005 > 0 °C 0.005 - 0.003% < 0 °C	N/A	0.001% of span
<b>Other input types</b>				
Millivolt Input		0.00025 mV	Entire sensor input range	0.001% of span
2-, 3-, 4-wire Ohm Input		0.007 Ω	Entire sensor input range	0.001% of span

(1) Change in ambient is in reference to the calibration temperature of the transmitter (20 °C [68 °F]).

(2) Ambient temperature effect specification valid over minimum temperature span of 28 °C (50 °F).

(3) Applies to /4–20 mA devices.

### Process temperature effects

**Table 5: Ambient and process temperature difference effect on digital accuracy**

Sensor option	Sensor reference	Effects per 1.0 °C(1.8 °F) difference in ambient and process temperature <sup>(1)</sup>	Input temperature (T)
Rosemount X-well Pt 100 (α = 0.00385)	IEC 751	± 0.01 °C (0.018 °F)	Entire sensor input range

(1) Valid under steady state process and ambient conditions.

### Temperature effects example

When using a Pt 100 (α = 0.00385) sensor input with a 0 to 100 °C span at 30 °C ambient temperature, the following statements would be true:

#### Digital temp effects

$$0.0015 \text{ } ^\circ\text{C}/^\circ\text{C} \times (30 - 20 \text{ } ^\circ\text{C}) = 0.015 \text{ } ^\circ\text{C}$$

#### D/A effects (HART/4–20 mA only)

- $[0.001\%/^\circ\text{C of span}] \times 100 \text{ } ^\circ\text{C} \times |(30 - 20 \text{ } ^\circ\text{C})| = \text{ } ^\circ\text{C DA effect}$
- $[0.001\%/^\circ\text{C} \times 100] \times |(30 - 20)| = 0.01 \text{ } ^\circ\text{C}$

#### Worst case error

$$\text{Digital} + \text{D/A} + \text{Digital temp effects} + \text{D/A effects} = 0.10 \text{ } ^\circ\text{C} + 0.02 \text{ } ^\circ\text{C} + 0.015 \text{ } ^\circ\text{C} + 0.01 \text{ } ^\circ\text{C} = 0.145 \text{ } ^\circ\text{C}$$

#### Total probable error

$$\sqrt{0.10^2 + 0.02^2 + 0.015^2 + 0.01^2} = 0.10 \text{ } ^\circ\text{C}$$

### Rosemount X-well temperature effects example

When using Rosemount X-well Technology at 30 °C ambient temperature and 100 °C process temperature:

#### Digital ambient temperature effects:

- $0.0058 \text{ } ^\circ\text{C} \times (30 - 20) = 0.058 \text{ } ^\circ\text{C}$

**Process temperature effects:**

- $0.01\text{ }^{\circ}\text{C} \times (100 - 30) = 0.70\text{ }^{\circ}\text{C}$

**Worst case error:**

- Digital accuracy + Digital ambient temperature effects + Process temperature effects =  
 $0.29\text{ }^{\circ}\text{C} + 0.058\text{ }^{\circ}\text{C} + 0.70\text{ }^{\circ}\text{C} = 1.05\text{ }^{\circ}\text{C}$

**Total probable error:**

- $\sqrt{0.29^2 + 0.058^2 + 0.70^2} = 0.76\text{ }^{\circ}\text{C}$

## HART/4-20 mA specifications

### Power supply

External power supply required. Transmitters operate on 12.0 to 42.4 Vdc transmitter terminal voltage (with 250 ohm load, 18.1 Vdc power supply voltage is required). Transmitter power terminals rated to 42.4 Vdc.

### Wiring diagram

See [Figure 8](#).

### Alarms

Custom factory configurations of alarm and saturation levels are available for valid values with option code C1. These values can also be configured in the field using a Field Communicator.

### Transient protection (option code T1)

The transient protector helps to prevent damage to the transmitter from transients induced on the loop wiring by lightning, welding, heavy electrical equipment, or switch gears. The transient protection electronics are contained in an add-on assembly that attaches to the standard transmitter terminal block. The external ground lug assembly (code G1) is included with the transient protector. The transient protector has been tested per the following standard:

- IEEE C62.41-1991 (IEEE 587)/location categories B3. 6 kV/3 kA peak (1.2 x 50  $\mu\text{S}$  Wave 8 x 20  $\mu\text{S}$  combination wave) 6 kV/0.5 kA peak (100 kHz ring wave) EFT, 4 kV peak, 2.5 kHz, 5 x 50 nS
- Loop resistance added by protector: 22 ohmsmax.
- Nominal clamping voltages: 90 V (common mode), 77 V (normal mode)

### Local display

Optional five-digit LCD display includes 0–100% bar graph. Digits are 0.4-in. (8 mm) high. Display options include engineering units ( $^{\circ}\text{F}$ ,  $^{\circ}\text{C}$ ,  $^{\circ}\text{R}$ , K, ohms, and millivolts), percent, and milliamperes. The display can also be set to alternate between engineering units/milliamperes, Sensor 1/Sensor 2, Sensor 1/Sensor 2/Differential Temperature, and Sensor 1/Sensor 2/Average Temperature. All display options, including the decimal point, may be reconfigured in the field using a Field Communicator or AMS Device Manager.

## Turn-on time

Performance within specifications is achieved less than six seconds after power is applied to the transmitter when the damping value is set to zero seconds.

## Power supply effect

Less than  $\pm 0.005$  percent of span per volt.

## SIS safety transmitter failure values

IEC 61508 Safety Certified SIL 2 and SIL 3 Claim Limit

- Safety accuracy: Span  $\geq 100$  °C:  $\pm 2\%$  of process variable span
- Span  $< 100$  °C:  $\pm 2$  °C
- Safety response time: five seconds
- Safety specifications and FMEDA report available at [Emerson.com/Rosemount/Support](https://www.emerson.com/Rosemount/Support)
- Software suitable for SIL3 applications

## Temperature limits

**Table 6: Temperature limits**

Description	Operating limit	Storage limit
Without LCD display	-40 to 185 °F -40 to 85 °C	-76 to 250 °F -60 to 120 °C
With LCD display <sup>(1)</sup>	-40 to 185 °F -40 to 85 °C	-76 to 185 °F -60 to 85 °C

<sup>(1)</sup> LCD display may not be readable, and LCD display updates will be slower at temperatures below  $-4$  °F ( $-20$  °C).

## Field Communicator connections

Field Communicator connections are permanently fixed to power/signal block.

## Failure mode

The Rosemount 3144P Temperature Transmitter features software and hardware failure mode detection. An independent circuit is designed to provide backup alarm output if the microprocessor hardware or software fails.

The alarm level is user-selectable using the failure mode switch. If failure occurs, the position of the hardware switch determines the direction in which the output is driven (HIGH or LOW). The switch feeds into the digital-to-analog (D/A) converter, which drives the proper alarm output even if the microprocessor fails. The values at which the transmitter drives its output in failure mode depends on whether it is configured to standard, or NAMUR-compliant (NAMUR recommendation NE 43) operation. The values for standard and NAMUR-compliant operation are as follows:

**Table 7: Operation parameters**

	Standard <sup>(1)</sup>	NAMUR-compliant <sup>(1)</sup>
Linear output	$3.9 \leq I \leq 20.5$	$3.8 \leq I \leq 20.5$
Fail high	$21 \leq I \leq 23$ (default)	$21.5 \leq I \leq 23$ (default)
Fail low	$I \leq 3.75$	$I \leq 3.6$

<sup>(1)</sup> Measured in milliamperes.

## Load limitations

Maximum load =  $40.8 \times (\text{Supply voltage} - 12.0)$  without transient protection (optional).

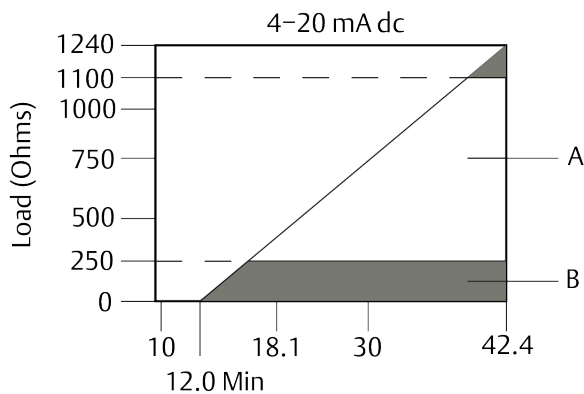

- A. and analog operating range  
 B. Analog only operating range

### Note

HART communication requires a loop resistance between 250 and 1100 ohms. Do not communicate with the transmitter when power is below 12 Vdc at the transmitter terminals.

## FOUNDATION™ Fieldbus specifications

### Power supply

Powered over FOUNDATION™ Fieldbus with standard Fieldbus power supplies. Transmitters operate on 9.0 to 32.0 Vdc, 12 mA maximum. Transmitter power terminals are rated to 42.4 Vdc.

### Wiring diagram

See [Figure 9](#).

### Alarm

The AI function block allows the user to configure the alarms to HIGH-HIGH, HIGH, LOW, or LOW-LOW with a variety of priority levels and hysteresis settings.

### Transient protection (option code T1)

The transient protector helps to prevent damage to the transmitter from transients induced on the loop wiring by lightning, welding, heavy electrical equipment, or switch gears. The transient protection electronics are contained in an add-on assembly that attaches to the standard transmitter terminal block. The transient terminal block is not polarity insensitive. The transient protector has been tested to the following standard:

- IEEE C62.41-1991 (IEEE 587)/location categories B3. 6 kV/3 kA peak (1.2 x 50 μS wave 8 x 20 μS combination wave) 6 kV/0.5 kA peak (100 kHz ring wave) EFT, 4 kV peak, 2.5 kHz, 5\*50 nS
- Loop resistance added by protector: 22 ohms, maximum
- Nominal clamping voltages: 90 V (common mode), 77 V (normal mode)

## Diagnostics suite for FOUNDATION Fieldbus (option code D01)

The Rosemount 3144P Temperature Transmitter Diagnostics Suite for FOUNDATION Fieldbus provides advanced functionality in the form of Statistical Process Monitoring (SPM), a thermocouple diagnostic, and sensor drift alert. SPM technology calculates the mean and standard deviation of the process variable and makes them available to the user. This may be used to detect abnormal process situations.

The thermocouple diagnostic enables the transmitter to measure and monitor the resistance of thermocouple loops in order to detect drift or changing wiring connections.

Sensor drift alert allows the user to monitor the difference in measurement between two sensors installed in one process point. A change in this differential value may indicate drifting sensors.

## Local display

Displays all DS\_65 measurements in the transducer and function blocks including Sensor 1, Sensor 2, differential, and terminal temperatures. The display alternates up to four selected items. The meter can display up to five digits in engineering units (°F, °C, °R, K, Ω, and millivolts). Display settings are configured at the factory according to the transmitter configuration (standard or custom). These settings can be reconfigured in the field using a Field Communicator or DeltaV. In addition, the LCD display provides the ability to display DS\_65 parameters from other devices.

In addition to the configuration of the meter, sensor diagnostic data is displayed. If the measurement status is **Good**, the measured value is shown. If the measurement status is **Uncertain**, the status indicating uncertain is shown in addition to the measured value. If the measurement status is **Bad**, the reason for the bad measurement is shown.

### Note

When ordering a spare electronics module assembly, the LCD display transducer block will display the default parameter.

## Turn-on time

Performance within specifications is achieved less than 20 seconds after power is applied to the transmitter when the damping value is set to zero seconds.

## Status

The device is compliant to NAMUR NE 107, ensuring consistent, reliable, and standardized device diagnostic information.

The new standard is designed to improve the way device status and diagnostic information is communicated to operators and maintenance personnel in order to increase productivity and reduce costs.

If self-diagnostics detect a sensor burnout or a transmitter failure, the status of the measurement will be updated accordingly. The status may also send the PID output to a safe value.

## FOUNDATION Fieldbus parameters

Schedule entries	25 (max)
Links	30 (max)
Virtual Communications Relationships (VCR)	20 (max)

## Function blocks

- All blocks will ship with unique block names, e.g. AI\_1400\_XXXX.
- All blocks shall be instantiated to avoid invalid defaults.
- All Rosemount 3144P FOUNDATION Fieldbus have parameter COMPATIBILITY\_REV for backward compatibility.

- Parameters will be initialized to common values for easier bench configuration.
- All default block tags are less than or equal to 16 characters in length to avoid inconvenience of apparently identical tags.
- Default block tags include underscores, “\_”, instead of whitespaces for easier configuration.

**Resource block**

- Contains physical transmitter information including available memory, manufacture identification, device type, software tag, and unique identification.
- Plantweb™ Alerts enable the full power of the Plantweb™ Insight digital architecture by diagnosing instrumentation issues, communicating the details, and recommending a solution.

**Transducer block**

- Contains the actual temperature measurement data, including sensor 1, sensor 2, and terminal temperature.
- Includes information about sensor type and configuration, engineering units, linearization, range, damping, and diagnostics.
- Device Revision 3 and above includes Hot Backup functionality in the transducer block.

**LCD display block (when an LCD display is used)**

- Configures the local display.

**Analog input (AI)**

- Processes the measurement and makes it available on the Fieldbus segment.
- Allows filtering, engineering unit, and alarm changes.
- All devices ship with the AI blocks scheduled, meaning no configuration is needed if the factory default channels are used.

**PID block (provides control functionality)**

- Performs single loop, cascade, or feedforward control in the field.

Block	Execution time
Resource	N/A
Transducer	N/A
LCD display block	N/A
Advanced diagnostics	N/A
Analog input 1, 2, 3, 4	60 milliseconds
PID 1 and 2 with autotune	90 milliseconds
Input selector	65 milliseconds
Signal characterizer	60 milliseconds
Arithmetic	60 milliseconds
Output splitter	60 milliseconds

## Product certifications

Rev 2.21

For Rosemount 3144P temperature transmitter with HART protocol product certifications, see [Rosemount 3144P Temperature Transmitter With HART Protocol and Rosemount X-well Technology](#).

## European Directive information

A copy of the EU Declaration of Conformity can be found at the end of the Quick Start Guide. The most recent revision of the EU Declaration of Conformity can be found at [Emerson.com/Rosemount](https://www.emerson.com/Rosemount).

## Ordinary location certification

As standard, the transmitter has been examined and tested to determine that the design meets the basic electrical, mechanical, and fire protection requirements by a Nationally Recognized Test Laboratory (NRTL) as accredited by the Federal Occupational Safety and Health Administration (OSHA).

## Dimensional drawings

Figure 2: Transmitter exploded view

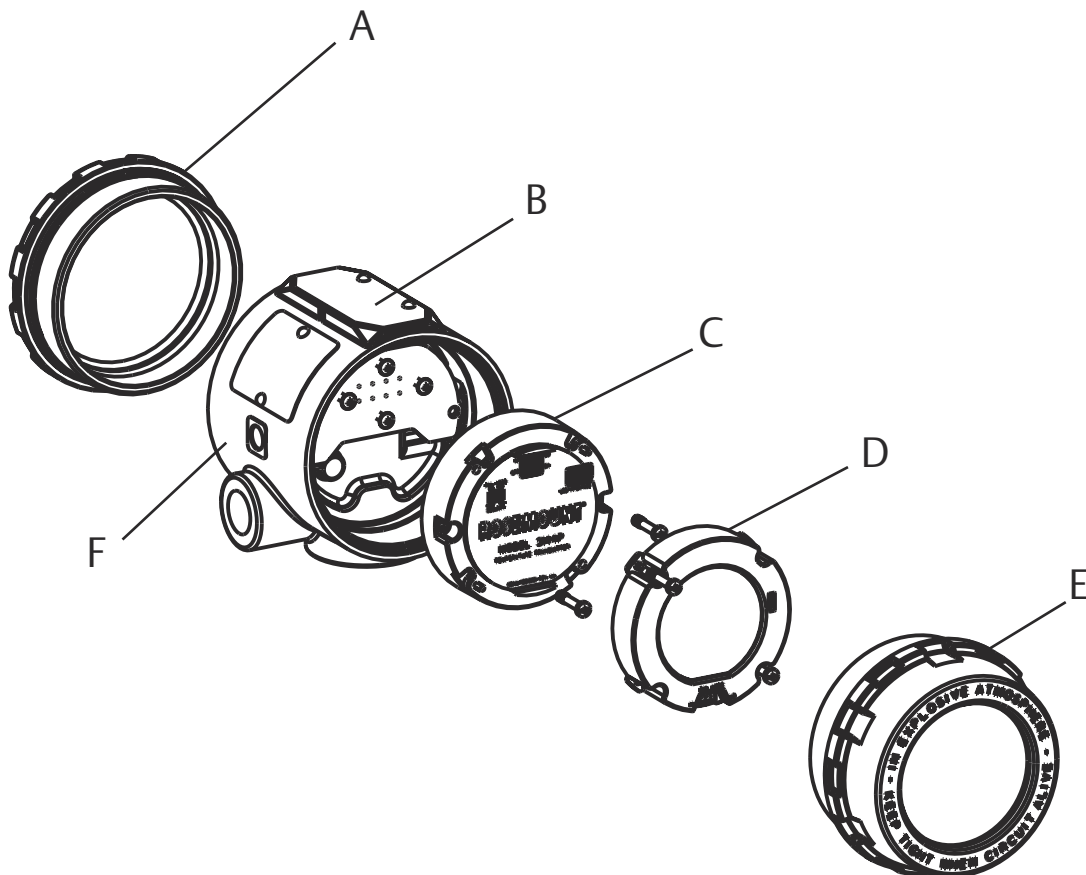

- A. Cover with wiring diagram
- B. Name plate
- C. Electronic module
- D. LCD display
- E. Display cover
- F. Housing with permanent terminal block

Figure 3: Switch location and LCD display face plate

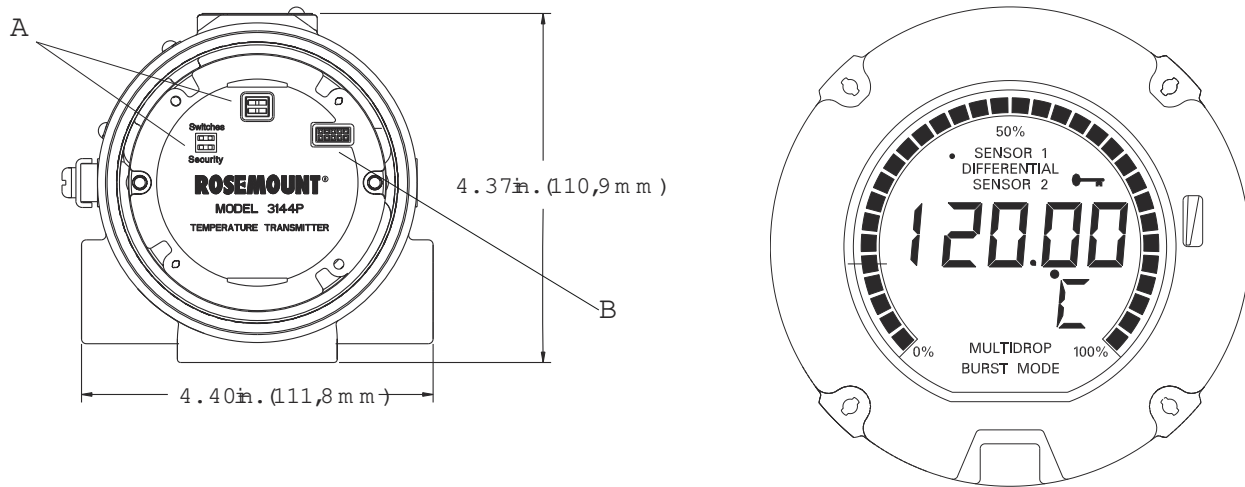

- A. Switches<sup>(1)</sup>
- B. LCD display connector

**Note**

Dimensions are in inches (millimeters).

Figure 4: Transmitter view

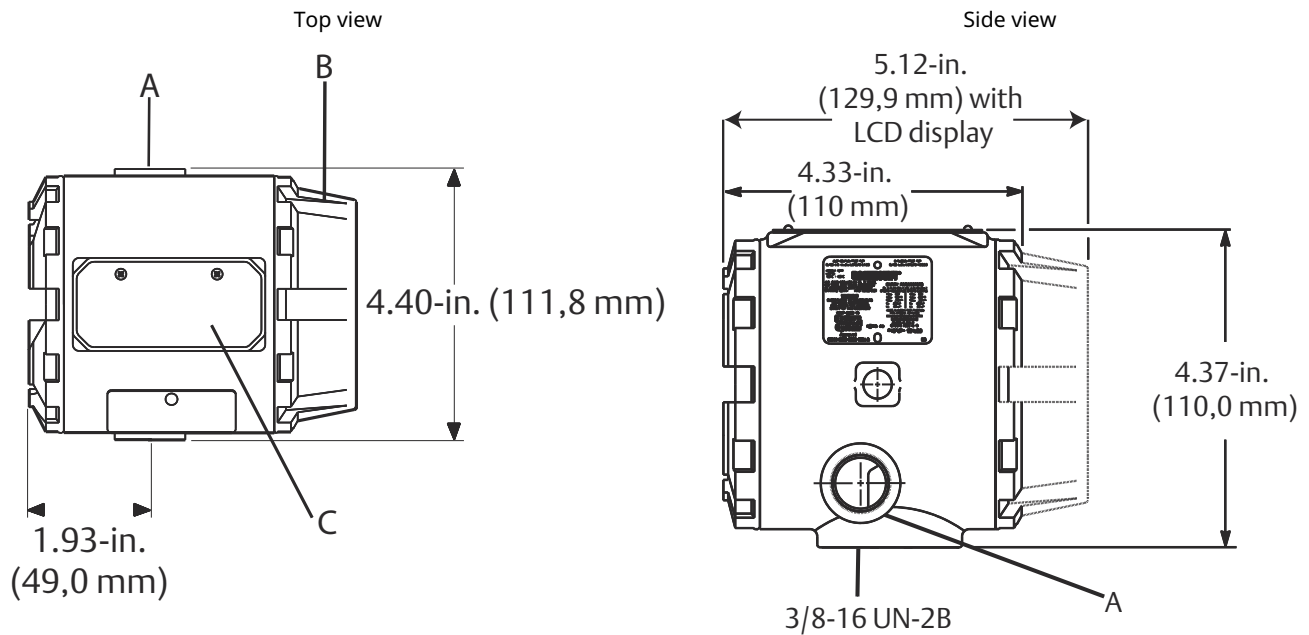

- A. Conduit entry
- B. Display cover
- C. Name plate

(1) Alarm and write protect (HART®), simulate and write protect (FOUNDATION™ Fieldbus).

**Note**

Dimensions are in inches (millimeters).

**Figure 5: Transmitter for conduits with M20 3 1.5, PG 13.5 entries**

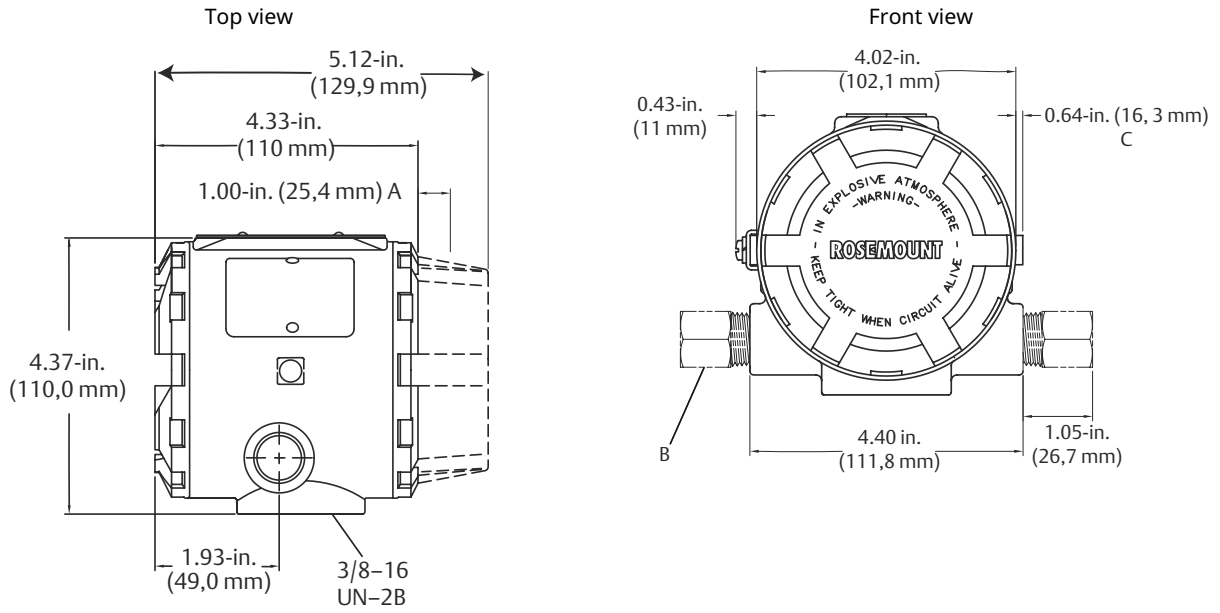

- A. Clearance required to remove cover
- B. Adapters for M20 x 1.5, PG 13.5
- C. Explosion/flameproof clamp (option code dependent)

**Note**

Dimensions are in inches (millimeters).

Figure 6: Pipe mounting configurations with optional mounting bracket

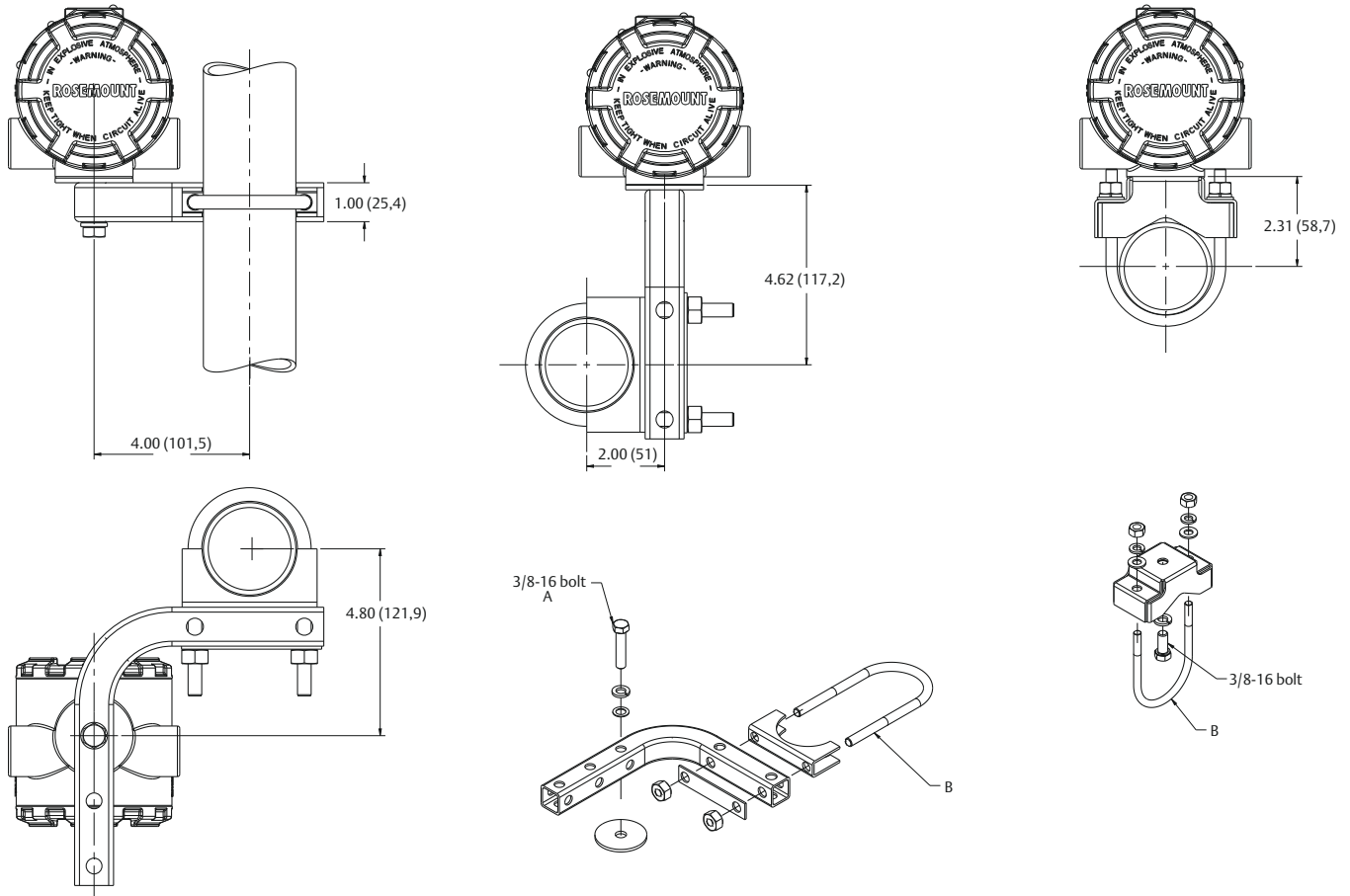

- A. For transmitter mounting
- B. 2-in. U-bolt for pipe mounting

**Note**

Dimensions are in inches (millimeters).

Figure 7: Rosemount X-well Assembly with Universal Pipe Mount

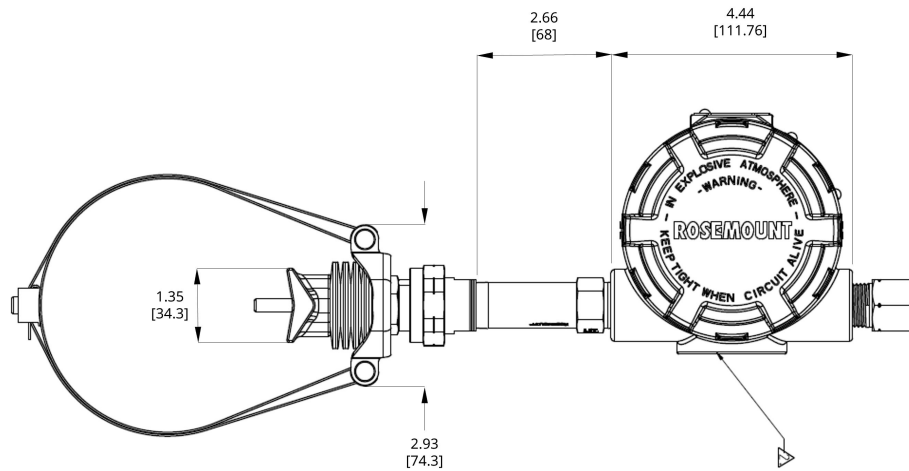
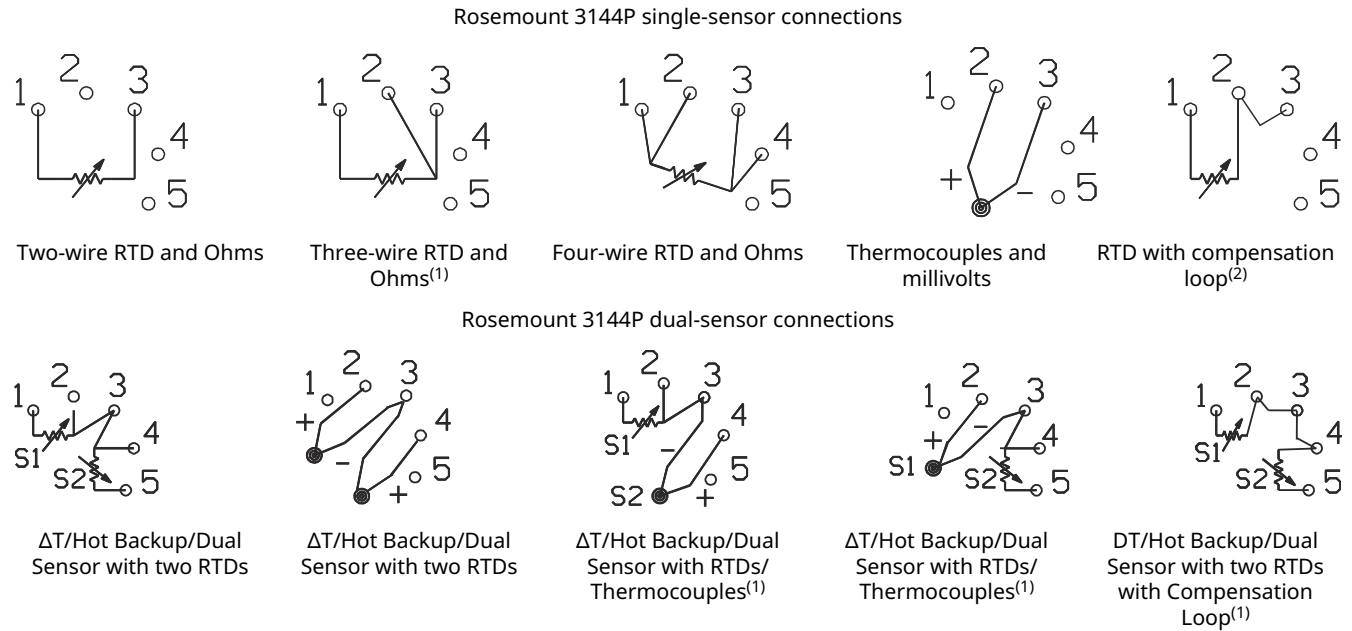
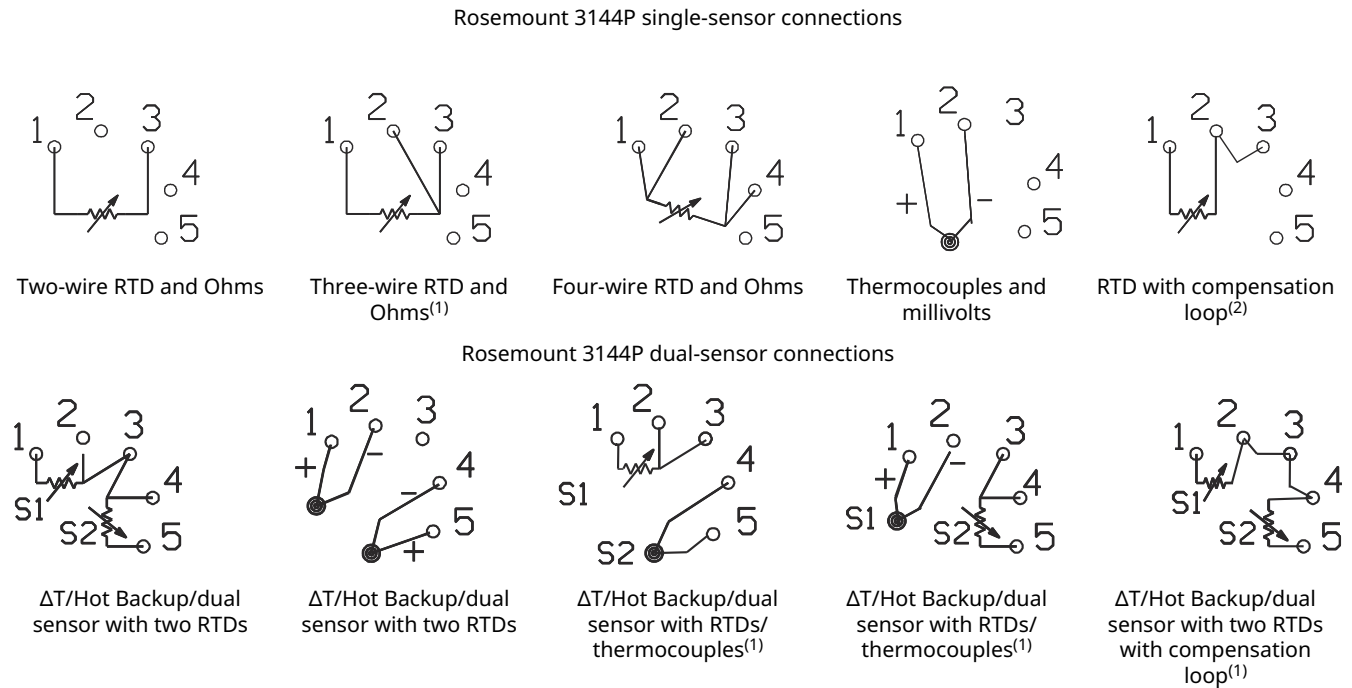

Figure 8: HART/4-20 mA



- (1) Emerson provides four-wire sensors for all single-element RTDs. Use these RTDs in two-wire or three-wire configurations by leaving the unneeded leads disconnected and insulated with electrical tape.
- (2) Transmitter must be configured for a three-wire RTD in order to recognize an RTD with a compensation loop.

Figure 9: FOUNDATION™ Fieldbus



- (1) Emerson provides four-wire sensors for all single-element RTDs. Use these RTDs in two-wire or three-wire configurations by leaving the unneeded leads disconnected and insulated with electrical tape.
- (2) Transmitter must be configured for a three-wire RTD in order to recognize an RTD with a compensation loop.

## Transmitter standard configuration

Both standard and custom configuration settings may be changed. Unless specified, the transmitter will be shipped as follows:

<b>Standard configuration</b>	
4 mA value/lower range (HART®/4–20 mA) measurement point LO (FOUNDATION™ Fieldbus)	0 °C
20 mA value/upper range (HART/4–20 mA) measurement point HI (FOUNDATION Fieldbus)	100 °C
Damping	5 seconds
Output	Linear with temperature
Failure mode (HART/4–20 mA)	High
Line voltage filter	60 Hz
Software tag	See <a href="#">Software tag</a>
Optional integral display	Units and mA/sensor 1 units
<b>Single-sensor option</b>	
Sensor type	4-wire, Pt 100 a = 0.00385 RTD
Primary variable (HART/4–20 mA) analog input (AI) 1400 (FOUNDATION Fieldbus)	Sensor 1
Secondary variable AI 1600 (FOUNDATION Fieldbus)	Terminal temperature
Tertiary variable	Not used
Quaternary variable	Not used
<b>Dual-sensor option</b>	
Sensor type	Two 3-wire, Pt 100 a = 0.00385 RTD
Primary variable (HART/4–20 mA) AI 1400 (FOUNDATION Fieldbus)	Sensor 1
Secondary variable AI 1500 (FOUNDATION Fieldbus)	Sensor 2
Tertiary variable AI 1600 (FOUNDATION Fieldbus)	Terminal temperature
Quaternary variable	Not used

## Transmitter custom configuration

The Rosemount 3144P Temperature Transmitter can be ordered with custom configuration. The table below lists the requirements necessary to specify a custom configuration.

Option code	Requirements/specification
C1: Factory data <sup>(1)</sup>	Date: day/month/year Descriptor: 16 alphanumeric character Message: 32 alphanumeric character Custom alarm levels can be specified for configuration at the factory. Rosemount X-well specific information: pipe material, pipe schedule, line size
C2: Transmitter-sensor matching	The Rosemount 3144P Temperature Transmitter is designed to accept Callendar-van Dusen constants from a calibrated RTD schedule and generate a custom curve to match any specific sensor curve. Specify a Rosemount RTD sensor model on the order with a special characterization curve (V or X8Q4 option). These constants will be programmed into the transmitter when this option is selected.
C4: Five point calibration	Will include five-point calibration at 0, 25, 50, 75, and 100 percent analog and digital output points. Use with option code Q4 to obtain a Calibration Certificate.
C7: Special sensor	Used for non-standard sensor, adding a special sensor or expanding input. Customer must supply the non-standard sensor information. Additional special curve will be added to sensor curve input choices.
A1: NAMUR-compliant, high alarm	Analog output levels compliant with NAMUR. Alarm is set to fail high.
CN: NAMUR-compliant, low alarm	Analog output levels compliant with NAMUR. Alarm is set to fail low.
C8: Low alarm	Analog output levels compliant with Rosemount standard. Alarm is set to fail low.
F5: 50 Hz Line voltage filter	Calibrated to 50 Hz line voltage filter.

(1) [Configuration Data Sheet](#) required.

To custom configure the Rosemount 3144P Temperature Transmitter with the dual-sensor option transmitter for one of the applications described below, indicate the appropriate option code in the model number. If a sensor type is not specified, the transmitter will be configured for two 3-wire Pt 100 ( $\alpha = 0.00385$ ) RTDs if any of the following option codes are selected.

Option code U1: Hot Backup	
Primary usage	Primary usage sets the transmitter to automatically use sensor 2 as the primary input if sensor 1 fails. Switching from sensor 1 to sensor 2 is accomplished without any effect on the analog signal. A digital alert will be sent in the event of a failed sensor.
Primary variable	1st good
Secondary variable	Sensor 1
Tertiary variable	Sensor 2
Quaternary variable	Terminal temperature

<b>Option code U2: average temperature with Hot Backup and sensor drift alert—warning mode</b>	
Primary usage	Critical applications, such as safety interlocks and control loops. Outputs the average of two measurements and sends a digital alert if temperature difference exceeds the set maximum differential (Sensor Drift Alert – warning mode). If a sensor fails, an alert will be sent digitally, and the primary variable will be reported as the remaining good sensor value.
Primary variable	Sensor average
Secondary variable	Sensor 1
Tertiary variable	Sensor 2
Quaternary variable	Terminal temperature

<b>Option code U3: average temperature with Hot Backup and sensor drift alert—alarm mode</b>	
Primary usage	Critical applications, such as safety interlocks and control loops. Outputs the average of two measurements and sets the analog output into alarm if temperature difference exceeds the set maximum differential (sensor drift alert – alarm mode). If a sensor fails, an alert will be sent digitally, and the primary variable will be reported as the remaining good sensor value.
Primary variable	Sensor average
Secondary variable	Sensor 1
Tertiary variable	Sensor 2
Quaternary variable	Terminal temperature

<b>Option code U4: two independent sensors</b>	
Primary usage	Used in non-critical applications where the digital output is used to measure two separate process temperatures.
Primary variable	Sensor 1
Secondary variable	Sensor 2
Tertiary variable	Terminal temperature
Quaternary variable	Not used

<b>Option code U5: differential temperature</b>	
Primary usage	The differential temperature of two process temperatures is configured as the primary variable. If the temperature difference exceeds the maximum differential, the analog output will go into alarm. Primary Variable will be reported as a bad sensor value.
Primary variable	Differential temperature
Secondary variable	Sensor 1
Tertiary variable	Sensor 2
Quaternary variable	Terminal temperature

<b>Option code U6: average temperature</b>	
Primary usage	When average measurement of two different process temperatures is required. If a sensor fails, the analog output will go into alarm, and the primary variable will report the measurement of the remaining good sensor.
Primary variable	Sensor average
Secondary variable	Sensor 1
Tertiary variable	Sensor 2
Quaternary variable	Terminal temperature



For more information: [Emerson.com/global](https://emerson.com/global)

©2023 Emerson. All rights reserved.

Emerson Terms and Conditions of Sale are available upon request. The Emerson logo is a trademark and service mark of Emerson Electric Co. Rosemount is a mark of one of the Emerson family of companies. All other marks are the property of their respective owners.

**Authorised Distributor:**



46, Jalan SS 22/21, Damansara Jaya,  
47400 Petaling Jaya,  
Selangor Darul Ehsan, Malaysia.  
Email: [ampmech@ampmech.com](mailto:ampmech@ampmech.com)  
Website: [www.ampmech.com](http://www.ampmech.com)

**ROSEMOUNT™**

