

Rosemount™ 3490 Controller



- Field mounted controller with physical buttons and easy-to-read colored display
- Modern user-centered interface design with a focus on ease-of-use for a quick setup
- Accepts 4-20 mA or HART® inputs
- Monitor open channel flows, pump control and level, tank volumes, and differential level

Introduction

Comprehensive control functionality for water and wastewater applications

The Rosemount 3490 Controller is part of Rosemount’s water and wastewater portfolio, designed to accompany the Rosemount 1208 Level and Flow Transmitters. To match these water and wastewater applications, the controller can be field mounted on either walls or pipes, as well as having a weather protection cover for increased screen visibility and an extra degree of protection in the worst outdoor environments.

Process performance is optimized by local control and automation through monitored measurement values, totalization, pump control, and calculated variables such as open channel flow measurements. The Rosemount 3490 also allows you to log measured values, easily accessible and shareable through a webserver. Up to two sensor inputs are available for connection of any 4-20 mA or HART® transmitter. To gain full pump operations control, level measurement metrics is used by controlling pumps or alarms through up to six output relays.

Although the controller has been developed specifically for the water and wastewater industry, its versatile functionalities make it applicable within other industries where 4-20 mA or HART transmitters are used.

Simple and user-friendly configuration wizards

The Rosemount 3490 is equipped with step-by-step wizards to guide the user through configuration and setup for the most common applications. The application wizards provide various configuration possibilities and options, such as level measurement, pump control, and flow calculations. All measurements can be totalized, differenced, logged, to then be displayed on the display. The following application wizards are available: Level and pump control, Open channel flow, Differential level, and Tank volume.

Figure 1: Wizard Selection Presented on the Controller Display

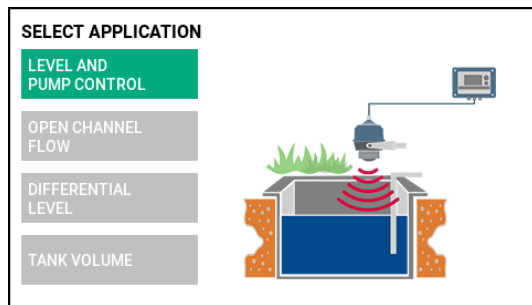

Contents

Introduction.....	2
Ordering information.....	6
General specifications.....	7
Electrical specifications.....	9
Mechanical specifications.....	11
Environmental specifications.....	12
Product certifications.....	13
Dimensional drawings.....	14

Intuitive user interface and easy-to-navigate menu structure

The controller's user interface has a simple and intuitive design, including a colored LCD display and physical keypad buttons to navigate through the software application. The display serves as an interface for the user to visualize measured values and status of inputs and outputs.

Modbus[®] TCP/IP communication to host

The Ethernet port can be used for Modbus TCP/IP connection to host systems. By simply connecting the controller to the existing LAN network, communication over Ethernet is established. Logged data is easily shared through the controller web interface.

Figure 2: Rosemount 3490 Modbus/TCP Communication to Host

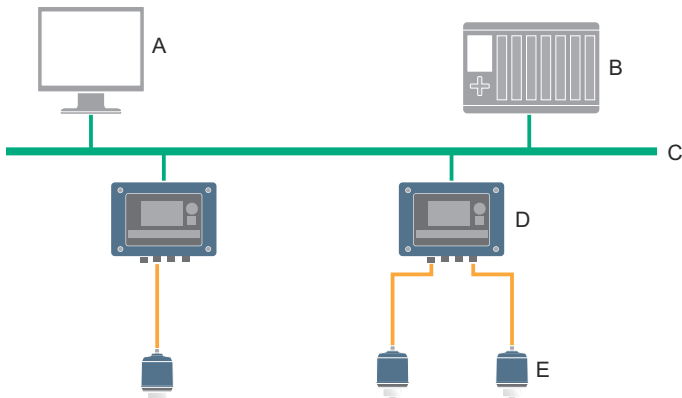

- A. PC
- B. Host
- C. LAN (Local Area Network)
- D. Rosemount 3490 Controller
- E. Rosemount 1208C Level and Flow Transmitter

Application examples

Level and pump control

Pump stations need accurate measurement and control to ensure an optimal water flow to the next stage of the potabilization process, while also avoiding overflows and pumps from dry-running. Level measurement is essential to ensure a sustainable extraction of water and a sufficient supply of water to the next phases of the potabilization process.

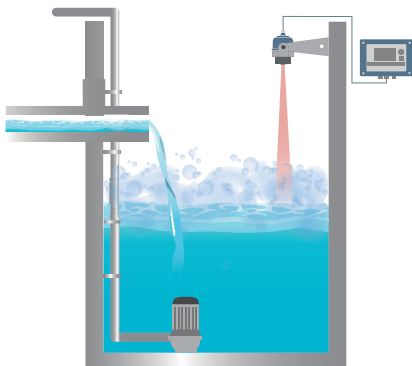

Open channel flow

Open-air channels transport water from a water source to a water plant where it will be processed. Flow monitoring in open channels is important to know the amount of water that is flowing to comply with regulations and avoid flooding.

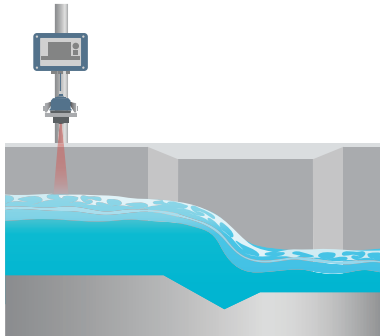

Differential level

In the screening process level measurement is necessary to monitor the level of water in the different parts of the screen, which will determine when to start the cleaning of the sieve.

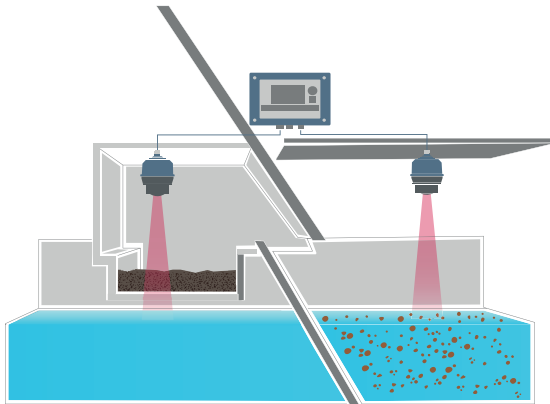

Tank volume

Storage tanks are used in water processes to store chemical substances, which are needed to treat the water. Level measurement is necessary to monitor, optimize chemical dosing, and avoid overfilling.

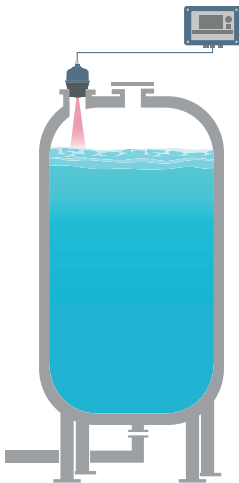

Access information when you need it with asset tags

Newly shipped devices include a unique QR code asset tag that enables you to access serialized information directly from the device. With this capability, you can:

- Access device drawings, diagrams, technical documentation, and troubleshooting information in your MyEmerson account
- Improve mean time to repair and maintain efficiency
- Ensure confidence that you have located the correct device
- Eliminate the time-consuming process of locating and transcribing nameplates to view asset information

Ordering information

Rosemount 3490 Controller



- Provides comprehensive control functionality for 4–20 mA or HART® compatible transmitters
- Modern exterior design with a user-centric interface
- Continuous access to information
- Pipe or wall mounting for easy field installation
- Weather protection cover to increase screen readability in sunlight, rain, hail, and snow

Models

Description	Model number
Rosemount 3490A Controller	3490A
Rosemount 3490C Controller	3490C

Related information

[Models](#)

Accessories

Mounting kit

Description	Part number
Wall and pipe mounting kit	03490-5000-0001

Weather protection

Description	Part number
Weather protection	03490-5000-0002

Glands and adapters

Description	Part number
Gland kit (4 pcs M20 cable glands including O-rings, 1 pcs M20 cable gland to Ethernet cable) ⁽¹⁾⁽²⁾	03490-5000-0003
½ NPT Adapter kit (3 pcs M20 to ½ NPT adapter)	03490-5000-0005

(1) 3 pcs cable glands including O-rings, and 5 pcs plugs including O-rings are shipped with each controller.

(2) M20 cable gland for Ethernet cable has no protection class (IP rating).

General specifications

Models

- Rosemount 3490A Controller
- Rosemount 3490C Controller

Table 1: Supported Applications

Application	Rosemount 3490A	Rosemount 3490C
Level and pump control	✓	✓
Open channel flow	✓	✓
Differential level	-	✓
Tank volume	✓	✓

Table 2: Number of Ports

Terminal	Number of ports	
	Rosemount 3490A	Rosemount 3490C
Sensor input	1	2
Digital input	2	4
Analog output	1	3
Relay output	3	6
Ethernet	1	1

Power supply

Power consumption

Maximum 12 W

Supply voltage

- AC: 100-240 Vac 50/60 Hz -15% to +10%

Fuse

2 A, 350 V

Start-up time

Approximately 30 seconds

Write protection

Yes

Memory card

Built-in memory card for logging function, up to 200.000 data points can be logged.

Update rate (software)

10 Hz

Supported HART[®] transmitters

Supported Rosemount transmitters

- Rosemount 1208C Level and Flow Transmitter
- Rosemount 3408 Level Transmitter
- Rosemount 5408 Level Transmitter
- Rosemount 5300 Level Transmitter
- Rosemount 3300 Level Transmitter
- Rosemount 3100 Level Transmitter

Generic support for HART transmitters

Support for data collection from other HART 5/7 level transmitters in accordance with HART practice

Display

Type

4.3 inch 480 x 272, backlit TFT LCD module color

Output units

- Level and distance: ft., in., m, cm, mm, %
- Volume: ft³, US gallon, imperial gallon, barrel, m³, l
- Flow rate: ft³/s, ft³/min, ft³/h, ft³/day, US gallon/min, US gallon/h, US gallon/day, UK gallon/min, UK gallon/h, UK gallon/day, Mega gallon/day, barrel/h, barrel/day, m³/s, m³/h, l/s, l/min, l/h

Keypad

Six buttons; up, down, left, right, back, and enter

Light emitting diode (LED)

One multi-colored LED for health status

Electrical specifications

Relay outputs

Up to six relay outputs

250 Vac 8 A/24 Vdc 8 A resistive load

Analog outputs

Up to three analog outputs

Signal range

4-20 mA

Accuracy

±0.02 mA (0.1% of 20 mA)

Resolution

12 bit

Maximum load

Load resistance must be in the interval: 120 Ω to 900 Ω

Power supply out

24 Vdc

Analog signal on alarm

The controller automatically and continuously performs self-diagnostic routines. If a failure or a calculated value error is detected, the analog signal will be driven offscale to alert the user. The fixed analog signal on alarm is user-configurable.

Table 3: Signal on Alarm

Standard	High	Low
Rosemount standard	21.75 mA	3.75 mA
NAMUR NE43	22.5 mA	3.6 mA

Analog saturation levels

The controller will continue to set a current that corresponds to the calculated value until reaching the associated saturation limit (and then freeze).

Table 4: Saturation Levels

Standard	High	Low
Rosemount standard	≥ 20.8 mA	≤ 3.9 mA
NAMUR NE43	≥ 20.5 mA	≤ 3.8 mA

Digital inputs

Up to four digital inputs, for use with potential-free contacts

Output voltage

14 V

Output current

6 mA

Sensor inputs

Up to two inputs, isolated from ground, for loop-powered/self-powered 4-20 mA/HART® transmitters

Signal range

4-20 mA

Accuracy

± 0.02 mA (0.1% of 20 mA)

Resolution

12 bit

Load limitations

Minimum output voltage is 14.4 Vdc. The maximum loop resistance quoted ensures there will be at least 12 Vdc available at the transmitter.

Table 5: Minimum Terminal Output Voltages

Load current (mA)	Rosemount 3490 terminal voltage (Vdc)	Maximum loop resistance (Ohms)
3.75	21.1	2427
4.0	21.1	2275
20.0	15.3	165
21.75	14.6	120
22.5	14.4	107

Ethernet

Modbus[®] TCP connection to host system, and/or web interface access for service functions and data log download

- 10/100 Mbps
- RJ45 connector

Isolation

Sensor inputs to other terminals

1.8 kV

Mechanical specifications

Material selection

Emerson provides a variety of Rosemount products with various product options and configurations, including materials of construction that can be expected to perform well in a wide range of applications. The Rosemount product information presented is intended as a guide for the purchaser to make an appropriate selection for the application. It is the purchaser's sole responsibility to make a careful analysis of all process parameters (such as all chemical components, temperature, pressure, flow rate, abrasives, contaminants, etc.), when specifying product, materials, options, and components for the particular application. Emerson is not in a position to evaluate or guarantee the compatibility of the process fluid or other process parameters with the product, options, configuration, or materials of construction selected.

Materials

Controller housing

Polybutylene Terephthalate/Polycarbonate (PBT)

Wall and pipe mounting kit

SST 316L

Weather protection

SST 316L

Weight

3.7 lb (1.7 kg)

Cable/conduit entries

- Seven M20 cable entries
- Support plate in stainless steel with M20 threads for cable glands or NPT adapters/conduit hubs

Terminal connection type

Spring loaded terminals

Environmental specifications

Temperature limits

Ambient temperature

-40 to +140 °F (-40 to +60 °C)⁽¹⁾

Storage temperature

-40 to +140 °F (-40 to +60 °C)

Humidity

0 - 100% relative humidity

Electrical safety

EN 61010-1:2010 (LVD)

Ingress protection

- Enclosure meets IP66/IP67 according to IEC 60529
- Enclosure meets Type 4X according to UL50E

Impact protection

Enclosure meets IK07

Maximum vibration

Vibration according to IEC 61298-3, level "field with general application"

(1) Display reading: -4 to +140 °F (-20 to +60 °C).

Installation category

Overtoltage category II (according to IEC 60664-1)

Pollution degree

Degree 2 according to IEC 61010-1

Metrology sealing possibility

Yes

Transient/built-in lightning protection

According to IEC 61326-1:2013

Surge

1 kV line-to-line

2 kV line-to-ground

Burst

2 kV (5 % 50 ns, 5 kHz)

Electromagnetic compatibility (EMC)

Emissions and immunity

EN 61326-1

Maximum altitude

6560 ft. (2000 m)

Product certifications

See the Rosemount 3490 [Product Certifications](#) document for detailed information on the existing approvals and certifications.

Dimensional drawings

Controller

Figure 3: Rosemount 3490

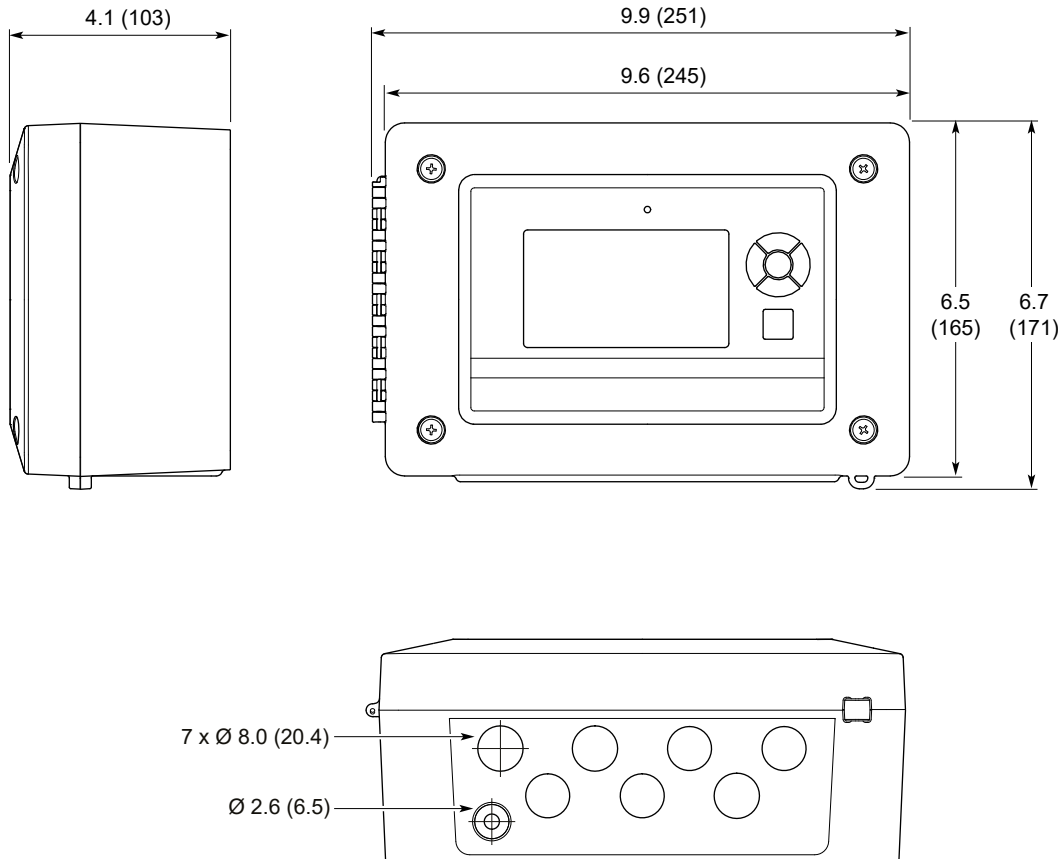

Dimensions are in inches (millimeters).

Support plate

Figure 4: Support Plate

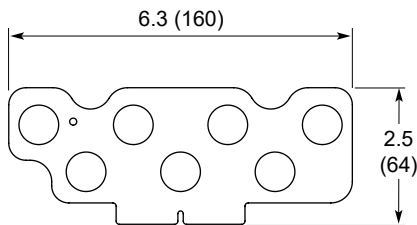

Dimensions are in inches (millimeters).

Wall and pipe mounting kit

Figure 5: Mounting Bracket

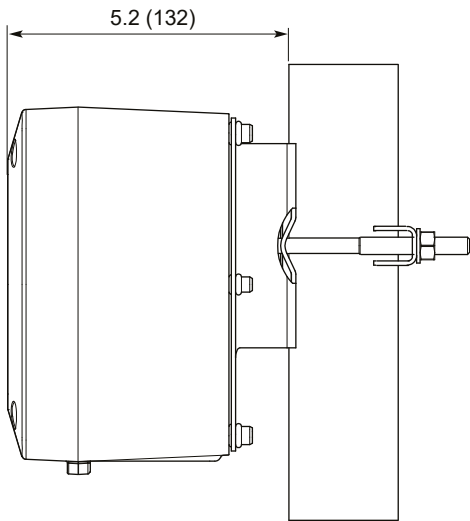

Dimensions are in inches (millimeters).

Bracket hole pattern

Figure 6: Hole Pattern for Wall Mounting

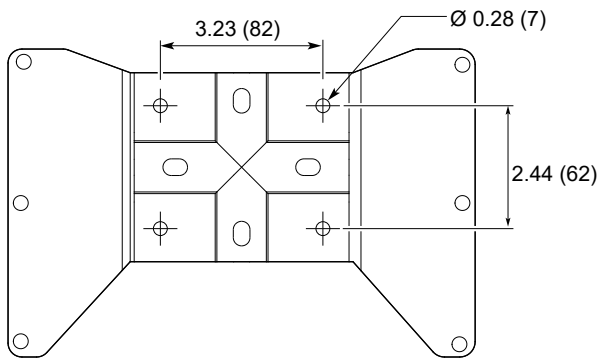

Dimensions are in inches (millimeters).

Weather protection

Figure 7: Weather protection

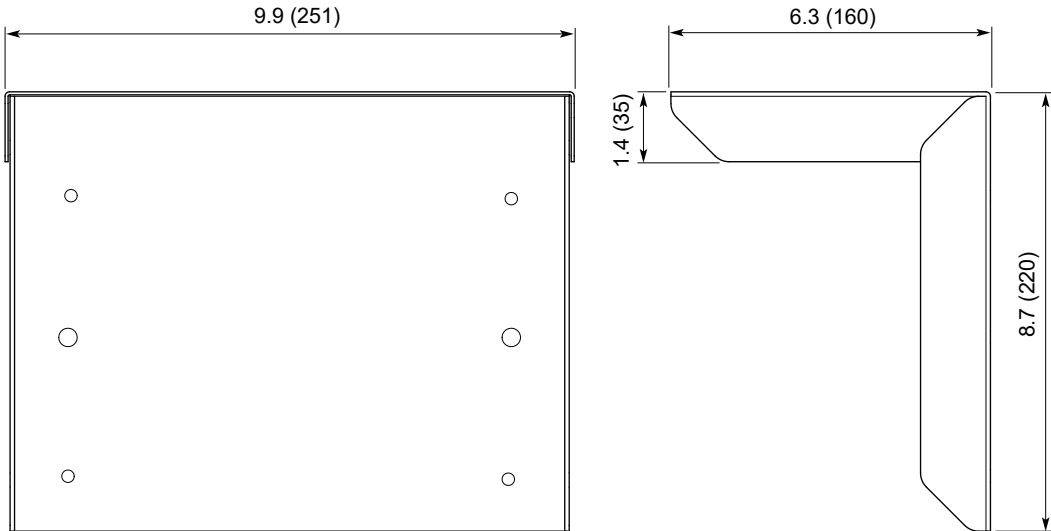

Dimensions are in inches (millimeters).

For more information: [Emerson.com/global](https://emerson.com/global)

©2024 Emerson. All rights reserved.

Emerson Terms and Conditions of Sale are available upon request. The Emerson logo is a trademark and service mark of Emerson Electric Co. Rosemount is a mark of one of the Emerson family of companies. All other marks are the property of their respective owners.

Authorised Distributor:



46, Jalan SS 22/21, Damansara Jaya,
47400 Petaling Jaya,
Selangor Darul Ehsan, Malaysia.
Email: ampmech@ampmech.com
Website: www.ampmech.com