

# BDTB18 – Industrial temperature gauge, bimetallic

## Product description

Badotherm thermometer model BDTB18 is available in 63 to 160 mm diameter. The BDTB18 is available with various connections, such as: fixed stem on back, bottom, or every angle connection. These bimetal thermometers are suitable for corrosive media and environments in chemical process, petroleum, and food industries.

## Design standard

EN 13190

## Dial sizes, ranges & accuracy

There are 3 dial sizes available for the bimetal temperature gauge. Both gauges have the same ranges and accuracy. Accuracy class is based on dry gauges at 23°C +/-10°C ambient temperature.

Dial size	Scale ranges	Accuracy class
63mm	Various ranges between -20 °C and +600 °C <sup>1</sup>	Class 1.0
100mm		
160mm		

<sup>1</sup>) standard range temperature delta: 60, 80, 100, 120, 140, 160, 200, 250, 300, 400, 500 and 600 °C

## Mounting variation

For the BDTB18 series the mounting variations are below.

- **type A** (01) bottom connection, direct mounting
- **type D** (03) center back connection, direct mounting

## Versions of stem mounting

Depending on the process different versions of mounting the stem (bulb) to the case. The versions are:

- **Fixed**; the stem is directly welded to the case
- **Every angle**; the stem is fixed with an adjustable device

## Process connection type

The process connection type can be selected freely. There are several options. Threaded option can be selected in multiple thread standards

- **Plain**; stem without thread
- **Fixed**; Thread fixed to the stem by welding
- **Adjustable**; thread adjustable by compression fitting
- **Rotatable (union) nut**; Female thread on fixed position
- **Rotatable (loose) nut**; Male thread on fixed position



## Materials of construction

	BDTB18
Case	AISI 304
Bezel	
Connection <sup>1</sup>	AISI 316
Stem <sup>1</sup>	TP316
Movement	Stainless steel
Pointer	Aluminium
Dial	
Window gasket	NBR
Fill plug	NBR (HNBR for filled gauges)
Window	glass

<sup>1</sup>) wetted materials

## Process connection size

Process connections of the BDTB temperature gauges are available in different sizes and types.

ISO 228-1	ISO 7-1	ANSI 1.20.1	DIN 13-1
G ¼ (A)	R ¼ (A)	¼" NPT	M14x1.5
G ⅜ (A)	R ⅜ (A)	⅜" NPT	M18x1.5
G ½ (A) ◀	R ½ (A)	½" NPT	M20x1.5
G ¾ (A)	R ¾ (A)	¾" NPT	M27x2

The small size threads (1/4" and M14) are only possible with 6mm stem. For both female and male there can be restriction per type of process connection.

-> See datasheet "thread information" for specific thread details

## Working range limitations

The gauges are built to withstand harsh environments however the EN 13190 limits the use of a temperature gauge according below table.

Continuous temperature load	Measuring range acc EN 13190
Short time (<1hr)	1.1x measuring range

## Temperature limitations

The gauges can withstand ambient and storage temperature up to a certain limit. The limitations on temperature on the case are:

	Ambient	Storage
Dry case	-40°C ...+60°C	-40°C ...+70°C

## Pressure limitations

The gauges can withstand a process static pressure of **25 bar** on the stem. Above these pressure it is advised to use a thermowell from our BDTW series.

## Window

Standard BDTB18 gauges have a glass window with option a laminated safety window.

## Pointer

Standard pointer is a fixed black painted aluminum pointer.

## Dial facing

The dial plate is made from aluminum and coated with UV resistant white coating. The black dial markings, scale, numbering, and interval is according the EN 13190. Options like rotated dial, colored dial, customer logo, or colored segments are possible as well. Scale interval and numbering is following the EN 13190.

## Degree of protection

The BDTB18 has a standard degree of protection of IP65. The values are determined according the IEC/EN 60529. Class IP67 is available as option.

## Zero adjustment

The BDTB18 100mm and 160mm has a standard zero adjustment screw on the back of the case. This allows a correction of +/- 4%.

## Case filling

The gauges cannot be case filled because of the open stem construction. The axle from the bimetal spring is directly led into the case. Filling with fluid will lead to pressure rising inside the case or boiling of the fill fluid. For case filled execution refer to the BDTG series.

## Certification & Declaration

### Calibration

Gauges are full range calibrated as a factory standard. Optionally you can select a 5 points calibration certificate.

[ATEX 114 - 2014/68/EU](#)

ATEX restrictions are explained in the IOM and in the ATEX background datasheet.

[EN 10204 material certificate](#)

A material 3.1 certificate on the wetted parts can be supplied.

## Standards used

### Design Standards

Standard	Description
EN 13190	Dial thermometers

### Material Standards

Standard	Description
NACE MR0175/MR0103 ISO 15156 - 2020	use in H <sub>2</sub> S-containing environments in oil and gas production
NORSOK M-630 - 2010	specification for use in pipelines
ASTM standards	Material specific standards

### Certification Standards

Standard	Description
EN 10204 - 2017	Inspection documents
ATEX 114 - 2014/68/EU	Equipment for potentially explosive atmospheres

## Error limit

The scale range and measuring range are determining the allowed error limit for the temperature gauge. The error limits are according the EN 13190 and in °C. Only class 1 error limits are mentioned as Badotherm do not make class 2 temperature gauges.

Scale Range (°C)	Measuring range (°C)	Class 1 (°C)
-20 + 40	-10 + 30	1
-20 + 50	-10 + 40	
-20 + 60	-10 + 50	
-20 + 80	-10 + 70	
-20 + 100	-10 + 90	2
-20 + 120	-10 + 110	
-20 + 140	-10 + 130	
-25 + 40	-15 + 30	1
-30 + 50	-20 + 40	
-30 + 70	-20 + 60	
-30 + 100	-20 + 90	2
0 + 60	0 + 50	1
0 + 80	0 + 70	
0 + 100	0 + 90	
0 + 120	20 + 110	2
0 + 150	20 + 130	
0 + 160	20 + 140	
0 + 200	20 + 180	
0 + 250	30 + 220	2.5
0 + 300	30 + 270	5
0 + 350	50 + 300	
0 + 400	50 + 350	
0 + 450	50 + 400	
0 + 500	50 + 450	
0 + 550	50 + 500	
0 + 600	100 + 500	10
50 + 650	150 + 550	
0 + 650	10 + 550	

## Minimum immersion length (L1)

For accurate measurement it is important to have the full sensing element immersed in the process or thermowell. The minimum immersion length in below table is taking this into account.

Scale Range (°C)	Measuring range (°C)	BDTB	BDTB DA
-20 + 40	-10 + 30	100	100
-20 + 50	-10 + 40	80	
-20 + 60	-10 + 50	63	
-20 + 80	-10 + 70		
-20 + 100	-10 + 90		
-20 + 120	-10 + 110	80	
-20 + 140	-10 + 130		
-25 + 40	-15 + 30	63	
-30 + 50	-20 + 40	80	
-30 + 70	-20 + 60	63	
-30 + 100	-20 + 90	80	
0 + 60	0 + 50	100	
0 + 80	0 + 70	63	
0 + 100	0 + 90		
0 + 120	20 + 110		
0 + 150	20 + 130		
0 + 160	20 + 140		
0 + 200	20 + 180		
0 + 250	30 + 220	150	
0 + 300	30 + 270		
0 + 350	50 + 300		
0 + 400	50 + 350		
0 + 450	50 + 400		
0 + 500	50 + 450		
0 + 550	50 + 500		
0 + 600	100 + 500		
50 + 650	150 + 550		
0 + 650	100 + 550		

## Stem diameters (S1)

Stem diameters are divided in metric and imperial tube sizes. Other tube sizes then these can be supplied on request.

Metric sizes	Imperial sizes
6mm	¼" (6.35)
8mm	3/8" (9.53)
10mm	½" (12.7)
12mm	

## Dimensions table

### Type A ; Fixed

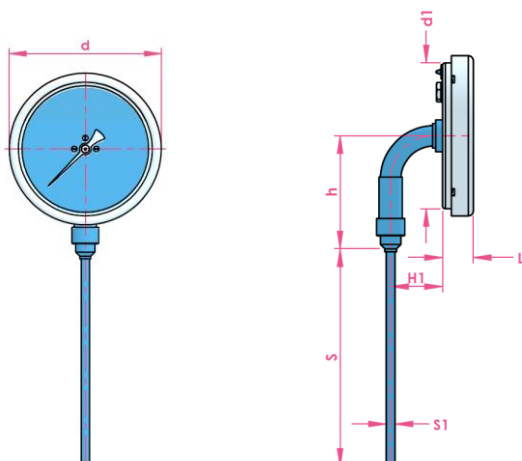

Dial size	d	d1	L	h	S1
63	68.6	63.0	15.7	57.0	variable
100	110.5	100.5	21.2	78.0	
160	160.0	149.0	21.5	104.0	

### Type D ; Fixed

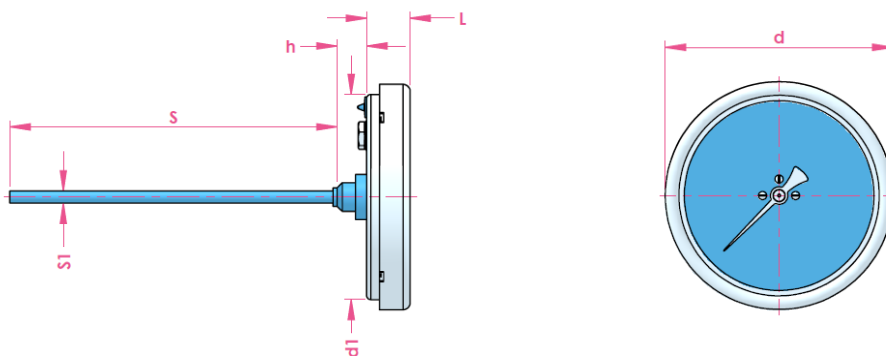

Dial size	d	d1	L	h	S1
63	68.6	63.0	15.7	14.5	variable
100	110.5	100.5	19.0		
160	160.0	149.0	21.5		

### Type DA ; Every angle

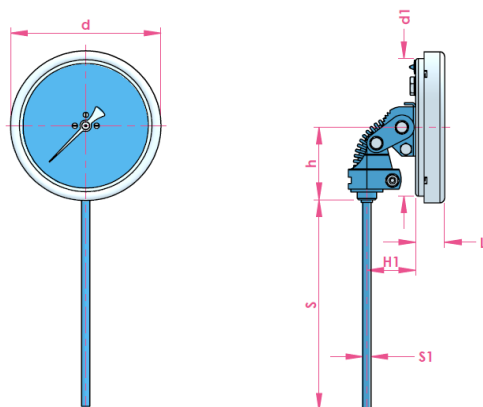

Dial size	d	d1	L	H1	h	S1
63	68.6	63.0	15.7	35.7	72.2	variable
100	110.4	100.5	21.2			
160	160.0	110.5	21.5			

## Connection details

Size S is a free choice with respect to the minimum insert length L1. This dimensions can be found in the table “minimum insert length”. The stem diameters can be found in the table “Stem diameters”.

### Fixed - male threaded connection *not for capillary*

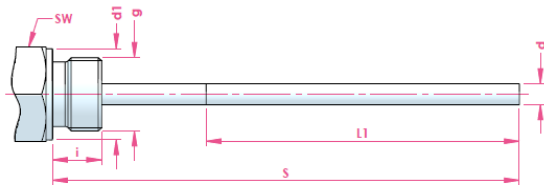

g	SW	i	d1
G ½ A	27	14	26
G ¾ A	32	16	32
1/2" NPT	22	19	NA
3/4" NPT	30	20	NA

### Plain - stem without thread

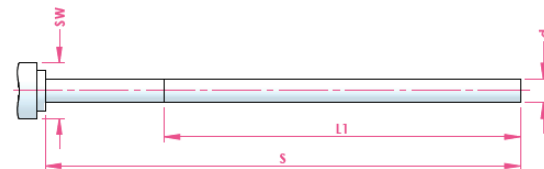

SW
22

### Male Nut – Rotatable loose nut

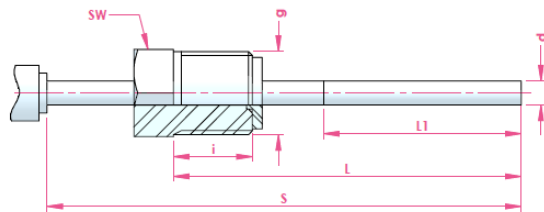

g	SW	i
G ½ A	27	20
M20x1.5	22	15

### Female nut – rotatable swivel nut

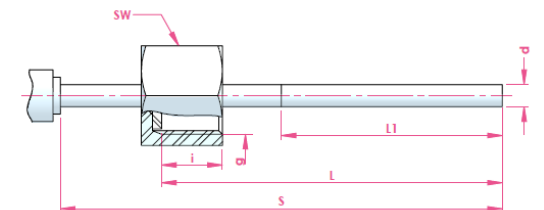

Size	G	SW	i
100, 160	G1/2B	27	8.5
	G3/4B	32	10.5
	M24x1.5	32	13.5

### Compression fitting – fitting on plain stem

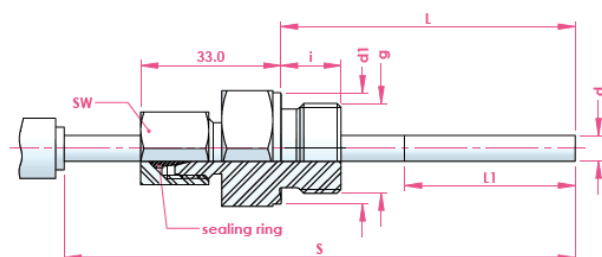

g	SW	i	d1
G ½ A	27	14	26
G ¾ A	32	16	32
M18x1.5	24	12	23
1/2"NPT	22	19	NA
3/4"NPT	30	20	NA

## Product code 63, 100, and 160mm

Selection	Suffix	Description
Temperature gauge type	BDTB18	Bimetal temperature gauge
Size	63	63mm case
	100	100mm case
	160	160mm case
Mounting	A ◀	Bottom connection - direct mounting (01) ◀
	D	Center back connection. - direct mounting (03)
Stem mounting	1	Fixed stem to the case
	2	Every Angle device to the case
Instrument connection	P	Plain stem without thread
	F	Fixed thread on the stem
	A ◀	Adjustable by compression fitting on stem
	R	Rotatable male or female nut
Stem diameter	M06 ◀	6mm
	I14	1/4"
	M08	8mm
	I38	3/8"
	M10	10mm
	M12	12mm
	I12	1/2"
Stem length	S100	S followed by length (eg "L100" for 100mm)
Connection (See table 6 for more options)	G38M	G 3/8" B
	G12M ◀	G 1/2" A
	N12M	1/2" NPT
	R12M	R 1/2
	M20M	M20x1.5
Case & Bezel	4 ◀	AISI 304
	6	AISI 316(L)
Window	L	Laminated safety glass
	G ◀	Glass
Range	C36	See table 1 and table 2

◀: is the sign for the standard temperature gauge

**Tabel 1: Temperature Range code**

°C		°F	
Code	Measuring Range	Code	Range
C04	-100 ... +50	<b>F15</b>	<b>-40 ... +180</b>
<b>C05</b>	<b>-100 ... +60</b>	<b>F27</b>	<b>0 ... +200</b>
C06	-100 ... +100	<b>F28</b>	<b>0 ... +250</b>
C07	-100 ... +500	<b>F29</b>	<b>+20 ... +240</b>
C09	-50 ... +50	<b>F43</b>	<b>+50 ... +400</b>
C10	-50 ... +70	<b>F44</b>	<b>+50 ... +550</b>
C11	-50 ... +100	<b>F45</b>	<b>+50 ... +750</b>
C12	-50 ... +200	<b>F49</b>	<b>+200 ... +1000</b>
<b>C13</b>	<b>-40 ... +40</b>	<b>F52</b>	<b>+400 ... +1200</b>
<b>C14</b>	<b>-40 ... +60</b>		
<b>C16</b>	<b>-30 ... +30</b>		
<b>C17</b>	<b>-30 ... +50</b>		
<b>C18</b>	<b>-30 ... +70</b>		
C19	-30 ... +100		
<b>C20</b>	<b>-20 ... +40</b>		
C21	-20 ... +50		
<b>C22</b>	<b>-20 ... +60</b>		
C23	-20 ... +80		
C24	-20 ... +100		
C25	-20 ... +110		
<b>C26</b>	<b>-20 ... +120</b>		
<b>C30</b>	<b>0 ... +60</b>		
<b>C31</b>	<b>0 ... +80</b>		
<b>C32</b>	<b>0 ... +100</b>		
<b>C33</b>	<b>0 ... +120</b>		
C34	0 ... +150		
<b>C35</b>	<b>0 ... +160</b>		
<b>C36</b>	<b>0 ... +200</b>		
<b>C37</b>	<b>0 ... +250</b>		
<b>C38</b>	<b>0 ... +300</b>		
<b>C39</b>	<b>0 ... +400</b>		
<b>C40</b>	<b>0 ... +500</b>		
<b>C41</b>	<b>0 ... +600</b>		
C42	0 ... +650		
C46	+50 ... +300		
C47	+50 ... +400		
<b>C48</b>	<b>+50 ... +650</b>		
C50	+100 ... +500		
<b>C51</b>	<b>+100 ... +700</b>		
...	<b>On request</b>		

Nominal Ranges in bold

**Table 2: Secondary scale**

Dual scale option	code
°C red	#CR
°C black	#CB
°C blue	#CBL
°F red	#FR
°F black	#FB
°F blue	#FBL
°R red	#RR
°R black	#RB
°R blue	#RBL

Add the code behind the temperature code (eg C35#FR for 0...160 °C /°F with red scale)

**Table 3: General option code**

Option (start options with X _)	code
IP 66 class	_IP66
IP 67 Class	_IP67
3.1 material certificate	_IC31
Calibration certificate 5 points	_CC5

**Table 4: thread options**

Thread standard	Thread sie	code
ISO 228-1	G 1/4 (A)	G14M
	G 3/8 (A)	G38M
	G 1/2(A) ◀	G12M
	G 3/4 (A)	G34M
ISO 7-1	R 1/4 (A)	R14M
	R 3/8 (A)	R38M
	R 1/2 (A)	R12M
ANSI 1.20.1	R 3/4 (A)	R34M
	1/4" NPT	N14M
	3/8" NPT	N38M
	1/2" NPT ◀	N12M
DIN 13-1	3/4" NPT	N34M
	M14x1.5	M14M
	M18x1.5	M18M
	M20x1.5	M20M
	M27x2	M27M

**Supplier:**

46, Jalan SS 22/21, Damansara Jaya,  
47400 Petaling Jaya,  
Selangor Darul Ehsan, Malaysia.

*Email: [ampmech@ampmech.com](mailto:ampmech@ampmech.com)*

*Website: [www.ampmech.com](http://www.ampmech.com)*

TB 7001 - 15th of March 2022

**Change log**

Date	Change

Holland – Romania – India – Thailand – Dubai – USA

To our knowledge, the information contained herein is accurate as of the date of this document. However neither Badotherm, nor its affiliates makes any warranty, express or limited, or accepts any liability in connection with this information or its use. This information is for technical skilled persons at their own discretion and risk and does not relate to the use of this product in combination with any other product. The user alone finally determines suitability of any information or material in contemplated use, the manner of use and whether any patents are infringed. This information gives typical properties only. Badotherm reserves the right to make changes to the specifications any materials without prior notice. The latest version of the datasheet can be found on [www.badotherm.com](http://www.badotherm.com).

© 2015 Badotherm, all rights reserved. Trademarks and/or other products referenced herein are either trademarks or registered trademarks of Badotherm.